



Queensland

*Transport Operations (Road Use Management) Act 1995*

# Transport Operations (Road Use Management—Vehicle Registration) Regulation 2010

Current as at 1 April 2021

## **Reprint note**

The *Transport Legislation (COVID-19 Emergency Response) Regulation 2020* modified this legislation from 10 April 2020 until 31 August 2021. These modifications did not amend the text of this law. Accordingly, while this point-in-time version does not contain textual amendments, it is affected by and must be read with the modifications that were in force at the same time.

© State of Queensland 2024



This work is licensed under a Creative Commons Attribution 4.0 International License.



Queensland

# Transport Operations (Road Use Management—Vehicle Registration) Regulation 2010

## Contents

---

		Page
<b>Part 1</b>	<b>Preliminary</b>	
1	Short title .....	9
2	Commencement .....	9
3	Definitions .....	9
4	Meaning of exempt vehicle .....	9
5	Meaning of registered operator in this regulation .....	11
5A	References to vehicle law .....	11
5B	Conforming with requirements of a vehicle law .....	12
6	Registered and unregistered vehicles .....	12
<b>Part 2</b>	<b>Registration principles</b>	
7	Garage address in Queensland .....	12
8	Persons eligible to register vehicle .....	13
9	Registration and conditional registration .....	13
10	Proof of compliance with vehicle law .....	13
<b>Part 3</b>	<b>Vehicle registration</b>	
<b>Division 1</b>	<b>Vehicles used on roads must be registered</b>	
11	Vehicles used on roads must be registered .....	14
<b>Division 2</b>	<b>Conditional registration</b>	
12	Conditional registration .....	14
<b>Division 3</b>	<b>Registration generally</b>	
13	Application for registration .....	15
14	Registration application made by agent .....	17
15	Driving or towing unregistered vehicle .....	17
16	Vehicle inspections .....	18

Contents

---

17	Deciding applications . . . . .	20
18	Registered vehicles register . . . . .	23
19	Registration certificates . . . . .	25
20	Registered operator to notify change of particulars . . . . .	26
21	Recording change in vehicle particulars and reassessment of registration fee . . . . .	28
22	Registration term . . . . .	29
23	Seasonal registration . . . . .	29
24	When registration becomes effective . . . . .	30
<b>Division 4</b>	<b>Approval of motorbikes as learner approved motorbikes</b>	
25	Purpose of div 4 . . . . .	30
26	Definition for div 4 . . . . .	31
27	Meaning of LAM test report . . . . .	31
28	Application for approval of motorbike as a learner approved motorbike 32	
<b>Division 5</b>	<b>Number plates</b>	
29	Chief executive to assign registration number and issue number plates 33	
30	Position, visibility and legibility of number plate . . . . .	34
31	Time for attaching number plates . . . . .	37
32	Q plates . . . . .	37
32A	Special edition number plates . . . . .	38
32B	Application to replace number plate with special edition number plate 38	
32C	Application to replace number plate with national heavy vehicle number plate . . . . .	39
33	Personalised number plates . . . . .	40
34	Transfer of personalised number plate . . . . .	42
35	Converting number plate to personalised number plate . . . . .	43
36	Customised number plates . . . . .	43
37	Accessory plates . . . . .	44
38	Accessory plate for tow truck . . . . .	45
39	When number plate must not be attached to a vehicle . . . . .	45
<b>Part 4</b>	<b>Renewal of registration</b>	
42	Registration renewal notice . . . . .	46
43	Renewal of registration . . . . .	47
44	When surcharge is payable for renewal . . . . .	49

45	Registration term if overpayment or underpayment of registration-related amount and any surcharge . . . . .	50
46	Administrative fee for late payment if cheque dishonoured . . . . .	52
47	Issue of receipt and updating of records . . . . .	52
<b>Part 5</b>	<b>Transfer of registration</b>	
48	Transfer of registration . . . . .	53
49	Failure by dealer to apply for transfer of registration . . . . .	56
50	Transfer of registration under legal process . . . . .	56
51	Refusing to record transfer of registration . . . . .	58
<b>Part 6</b>	<b>Expiry and cancellation of registration</b>	
<b>Division 1</b>	<b>Expiry of registration</b>	
52	Expiry of registration . . . . .	59
53	Return of registration plates when registration expires . . . . .	59
<b>Division 2</b>	<b>Cancellation of registration</b>	
54	Cancellation of registration at registered operator's request . . . . .	60
55	Cancellation if registration in other State . . . . .	62
55A	Cancellation of registration at request of chief executive officer of a local government . . . . .	62
55B	Cancellation of registration at request of the commissioner . . . . .	63
56	Partial refund of registration fee . . . . .	63
57	Cancellation for noncompliance with notice about defective or unsafe vehicle . . . . .	64
58	Cancellation of registration of vehicle or dealer plate . . . . .	65
59	Recording cancellation of registration in register . . . . .	67
59A	Cancellation of heavy vehicle registration by court . . . . .	68
<b>Part 7</b>	<b>When registration unnecessary</b>	
<b>Division 1</b>	<b>Unregistered vehicle permits</b>	
60	Unregistered vehicle permits . . . . .	69
<b>Division 2</b>	<b>Dealer plates</b>	
61	Designation of dealer plates . . . . .	70
62	Registration of dealer plate . . . . .	70
63	Attaching dealer plate . . . . .	71
64	Use of dealer plates . . . . .	72
65	Cancellation of dealer plates . . . . .	74
<b>Part 8</b>	<b>Written-off vehicles</b>	
<b>Division 1</b>	<b>Objects of part 8</b>	
66	Objects . . . . .	77

Contents

---

<b>Division 1A</b>	<b>Classification of written-off vehicles</b>	
66A	Written-off vehicle to be classified as statutory write-off or repairable write-off . . . . .	77
<b>Division 2</b>	<b>Notifying of written-off vehicle information</b>	
67	General obligations of notifiers . . . . .	78
68	Auditing of notifiers . . . . .	78
68A	Chief executive to advise notifier of label specifications . . . . .	79
69	Obligation of notifiers to give notifiable information . . . . .	79
70	Obligation of insurer to report written-off vehicle . . . . .	80
71	Obligation of self-insurer to report written-off vehicle . . . . .	81
72	Obligation of loss adjuster to report written-off vehicle . . . . .	82
73	Obligation of dealer or auctioneer to report written-off vehicle . . . . .	82
74	Obligation of auto parts dismantler to report written-off vehicle . . . . .	83
75	Obligation of registered operator or owner of unregistered vehicle to report written-off vehicle . . . . .	84
75A	Chief executive to give label for written-off vehicle to registered operator or owner of unregistered vehicle . . . . .	85
76	Notifier’s obligation to inform registered operator or owner of unregistered vehicle . . . . .	86
77	Notifier’s obligation to attach label to written-off vehicle . . . . .	86
78	Obligation on registered operator or owner of unregistered vehicle to attach label to written-off vehicle . . . . .	87
79	Offence to remove written-off vehicle label . . . . .	88
80	Written-off vehicles must not be used on road . . . . .	88
<b>Division 3</b>	<b>Written-off vehicle inspections</b>	
81	Definition for div 3 . . . . .	90
82	Approvals . . . . .	90
83	Conditions of approval . . . . .	91
84	Granting or refusing to grant approval . . . . .	91
85	Approval prescribed for Act, ss 17B(2) and 18(1)(c)(ii) . . . . .	92
<b>Division 4</b>	<b>Offences relating to written-off vehicle inspections</b>	
86	Performing written-off vehicle inspection when not approved . . . . .	92
87	Supervising written-off vehicle inspections when not approved . . . . .	92
88	Not complying with conditions of approval . . . . .	92
89	False or misleading written-off vehicle inspection report . . . . .	93
90	Operating place as a written-off vehicle inspection site . . . . .	93
91	Performing written-off vehicle inspection at place other than written-off vehicle inspection site . . . . .	93

92	Supervising written-off vehicle inspections at place other than written-off vehicle inspection site . . . . .	93
93	False advertising or holding out . . . . .	94
<b>Part 9</b>	<b>Measures for natural disasters or droughts</b>	
<b>Division 1</b>	<b>Measures for natural disasters</b>	
94	Application of div 1 . . . . .	94
95	Definitions for div 1 . . . . .	94
96	Natural disaster relief notice . . . . .	95
97	Reduced term of registration or renewal of registration . . . . .	95
98	Exemption from surcharge for reduced registration term or from administrative fee for late payment . . . . .	95
99	Seasonal registration—deferral of registration . . . . .	96
100	Section 97, 98 or 99 may be relied on only once . . . . .	96
<b>Division 2</b>	<b>Measures for droughts</b>	
100A	Application of div 2 . . . . .	96
100B	Definitions for div 2 . . . . .	98
100C	Reduced term of registration or renewal of registration . . . . .	98
100D	Exemption from surcharge for reduced registration term or from administrative fee for late payment . . . . .	99
100E	Required evidence or notice must be given . . . . .	99
100F	Seasonal registration—deferral of registration . . . . .	100
<b>Division 3</b>	<b>Measure for transport of fodder for disaster or drought-affected primary producer</b>	
100G	Transport of fodder by primary producer for another primary producer 100	
<b>Part 10</b>	<b>Miscellaneous</b>	
<b>Division 1</b>	<b>Other provisions about number plates</b>	
101	Replacing damaged, destroyed, lost or stolen number plates . . . . .	102
101A	Replacing unlawfully copied number plates . . . . .	103
102	Chief executive may require exchange of number plates . . . . .	104
103	Chief executive may require return of number plates . . . . .	106
104	Property in number plates . . . . .	107
<b>Division 2</b>	<b>Vehicles temporarily in Queensland</b>	
105	Vehicles temporarily in Queensland . . . . .	107
<b>Division 3</b>	<b>Other miscellaneous provisions</b>	
105A	Vehicle registered in another State in name of defence force member or eligible family member . . . . .	110
106	Sale of unregistered vehicles by dealers . . . . .	111

Contents

---

107	Authorisation to use unregistered vehicle on roads . . . . .	111
108	Permit to use intercepted unregistered vehicle on road . . . . .	113
109	Damaged or dirty number plates . . . . .	114
<b>Division 3A</b>	<b>Requirements for particular applications etc.</b>	
<b>Subdivision 1</b>	<b>Preliminary</b>	
109A	Definitions for division . . . . .	115
<b>Subdivision 2</b>	<b>Particular applications</b>	
109B	Chief executive may publish a notice about applications . . . . .	116
109C	How applications must be made . . . . .	117
109D	Chief executive may request further information . . . . .	117
<b>Subdivision 3</b>	<b>Particular customer communications</b>	
109E	Chief executive may publish a notice about particular customer communications . . . . .	118
109F	How customer communications must be given or made . . . . .	119
<b>Division 4</b>	<b>Review of decisions</b>	
110	Decisions to which this division applies . . . . .	119
111	Review of decision . . . . .	120
<b>Division 5</b>	<b>Release of information</b>	
112	Definitions for div 5 . . . . .	120
115	Release of information on payment of amount or fee . . . . .	124
115A	Amount payable for release of information to particular entities . . . . .	125
116	Release of information to relevant tolling entities and other persons . . . . .	126
116A	Release of information to entity that maintains NEVDIS . . . . .	128
117	Release of vehicle-related information . . . . .	128
118	Amount or fee payable to vehicle-related information provider . . . . .	131
<b>Division 6</b>	<b>Use of information from register for particular purposes</b>	
119	Use of information for contacting registered operator about moving or removing vehicle . . . . .	131
119A	Use of information for contacting registered operator about recovery of cost of damage . . . . .	132
<b>Division 7</b>	<b>When registration certificate may be made available electronically</b>	
119B	Making particular registration certificates electronically available . . . . .	133
<b>Part 11</b>	<b>Fees</b>	
<b>Division 1</b>	<b>General</b>	
120	Fees . . . . .	134
121	Charging categories . . . . .	135
<b>Division 2</b>	<b>Vehicles exempted from fees</b>	



122	Exemption from payment of fee . . . . .	136
122A	Exemption from payment of national heavy vehicle number plate fees 139	
<b>Division 3</b>	<b>Concessional registration fees for particular category 1 vehicles</b>	
123	Concessional registration fees—category 1 vehicles . . . . .	139
<b>Division 4</b>	<b>Concessional registration fees for category 2 vehicles</b>	
124	Concessional registration fees—primary production vehicles . . .	141
125	Concessional registration fee for motorised caravan for card holders and prescribed service persons . . . . .	143
126	Concessional registration fees for other vehicles . . . . .	144
<b>Part 12</b>	<b>Other offence provisions and power to recover number plates in particular circumstances</b>	
127	Offences involving registration certificates etc. . . . .	146
128	Requirement to remove unlawful registration item . . . . .	148
128A	Authorised officer may remove and recover number plates in particular circumstances . . . . .	149
<b>Part 13</b>	<b>Repeal and transitional provisions</b>	
<b>Division 1</b>	<b>Repeal</b>	
129	Repeal of regulation . . . . .	149
<b>Division 2</b>	<b>Transitional provision for repeal</b>	
130	References to repealed regulation . . . . .	149
<b>Division 3</b>	<b>Transitional provisions for Transport Operations (Road Use Management—Vehicle Registration) Amendment Regulation (No. 2) 2014</b>	
131	Definitions for div 3 . . . . .	150
132	No obligation to attach registration labels for stated vehicles . . .	150
133	No obligation to issue registration certificate or label for stated vehicles 150	
134	Cancellation notices under former ss 57 and 58 . . . . .	151
135	Cancellation of dealer plates under former s 65 . . . . .	152
136	Replacement registration labels for stated vehicles under former s 101 152	
<b>Division 4</b>	<b>Transitional provision for Transport and Other Legislation (Personalised Transport Reform) Amendment Regulation (No. 2) 2017</b>	
137	Notifying change of purpose of use for vehicle used for booked hire service . . . . .	152
<b>Division 5</b>	<b>Transitional provisions for Transport Operations (Road Use Management—Vehicle Registration) (Heavy Vehicles) Amendment Regulation 2018</b>	

Contents

---

138	Definition for division . . . . .	153
139	No obligation to attach registration labels for category 2 vehicles . . . . .	153
140	No obligation to issue registration certificate or label for category 2 vehicles . . . . .	154
141	Cancellation notices under former ss 57 and 58 . . . . .	154
142	Replacement registration labels for category 2 vehicles under former s 101 . . . . .	154
<b>Division 6</b>	<b>Transitional provision for Transport Operations (Road Use Management—Vehicle Registration) and Other Legislation Amendment Regulation 2019</b>	
143	Fees . . . . .	155
<b>Schedule 1</b>	<b>Category 1 vehicle registration fees for 1 year . . . . .</b>	<b>156</b>
<b>Schedule 2</b>	<b>Category 2 vehicle registration fees for 1 year . . . . .</b>	<b>161</b>
<b>Schedule 3</b>	<b>Other fees . . . . .</b>	<b>168</b>
<b>Schedule 4</b>	<b>Provisions that particular items of schedule 1, part 2 and schedule 2, part 3 are subject to . . . . .</b>	<b>175</b>
<b>Schedule 5</b>	<b>Vehicles for particular concessional registration fees . . . . .</b>	<b>178</b>
2	Local government vehicle . . . . .	178
3	Community service organisation vehicle . . . . .	178
4	Vehicle used only in particular areas . . . . .	178
5	Vehicle used solely to cross roads within an agricultural property . . . . .	179
6	Vehicle used solely to travel between 2 agricultural properties, or 2 mining properties, directly across the road from each other . . . . .	179
7	Vehicle used solely for fencing of primary producer’s property . . . . .	179
8	Vehicle used solely as a mobile workshop for carrying on business of beekeeping . . . . .	180
9	Vehicle used solely to cross roads within a mining property . . . . .	180
10	Vehicle used solely to carry on business of oil, mineral or water exploration . . . . .	180
11	Vehicle used solely for carrying on business of prospecting in particular local government areas . . . . .	181
12	Vehicle used solely for carrying on business of well boring . . . . .	181
<b>Schedule 6</b>	<b>Local government areas for schedule 5, section 11 for vehicles used solely to carry on business of prospecting . . . . .</b>	<b>182</b>
<b>Schedule 7</b>	<b>Grounds for cancellation of registration of registered vehicle . . . . .</b>	<b>184</b>
<b>Schedule 8</b>	<b>Dictionary . . . . .</b>	<b>188</b>

---

# Transport Operations (Road Use Management—Vehicle Registration) Regulation 2010

## Part 1 Preliminary

### 1 Short title

This regulation may be cited as the *Transport Operations (Road Use Management—Vehicle Registration) Regulation 2010*.

### 2 Commencement

This regulation commences on 1 September 2010.

### 3 Definitions

The dictionary in schedule 8 defines particular words used in this regulation.

### 4 Meaning of *exempt vehicle*

In this regulation, a vehicle is an *exempt vehicle* if the vehicle is—

- (a) an agricultural implement being towed by—
  - (i) an agricultural machine suitably matched to the implement; or
  - (ii) another vehicle of a suitable size for towing the implement; or
- (b) a trailer being towed by—
  - (i) an agricultural machine that is being used for its intended agricultural purpose; or

[s 4]

---

- (ii) a conditionally registered vehicle with limited access registration; or
- (c) a motorised golf buggy or other motorised machinery being used on a golf course or on a golf course car park, or a motorised golf buggy being used for directly crossing a road dividing a golf course; or
- (d) a ride-on mower, other than a ride-on mower that is an agricultural machine, that is being used for mowing, and is—
  - (i) directly crossing a road; or
  - (ii) crossing from 1 road-related area to another road-related area; or
  - (iii) on a road-related area; or
- (e) walking speed equipment that is on a road only for—
  - (i) loading it onto, or unloading it from, another vehicle; or
  - (ii) repositioning it at a work site; or
- (f) a low-powered motor vehicle; or
- (g) a vehicle that is not a motor vehicle or a trailer; or
- (h) a vehicle being towed by a tow truck; or
- (i) a racing vehicle being used on a racing track or in a related area for a racing track; or
- (j) a motorbike being used in freestyle motocross in a freestyle motocross area; or
- (k) a motorbike being used in an observed trial in an observed trial area; or
- (l) drawn plant being towed by a conditionally registered vehicle of a size suitable for towing the plant; or
- (m) a motorised wheelchair being used by a person who—
  - (i) does not usually reside in Queensland; or

- 
- (ii) has resided in Queensland for not more than 14 days; or
  - (n) an unregistered motor vehicle that is dealer's stock being used on the dealer's premises.

## 5 Meaning of *registered operator* in this regulation

- (1) This section defines *registered operator* for its use in this regulation only, and has effect despite the expression's definition in the Act.
- (2) The *registered operator* of a vehicle is the person in whose name the vehicle is currently registered.
- (3) The *registered operator* of a dealer plate is the person in whose name the dealer plate is currently registered.

## 5A References to *vehicle law*

For the application of a provision of this regulation to a vehicle, a reference in the provision to a *vehicle law* is a reference to—

- (a) if the vehicle is a heavy vehicle—any of the following under the Heavy Vehicle National Law (Queensland) to the extent they apply to the vehicle—
  - (i) the heavy vehicle standards;
  - (ii) the mass requirements;
  - (iii) the dimension requirements; or
- (b) otherwise—any of the following to the extent they apply to the vehicle—
  - (i) the Vehicle Standards and Safety Regulation, part 2A, divisions 2 and 3;
  - (ii) the vehicle standards under the Vehicle Standards and Safety Regulation.

[s 5B]

---

## **5B Conforming with requirements of a vehicle law**

For this regulation, a vehicle is taken to conform with the requirements applying to the vehicle under a vehicle law if it conforms with all the requirements other than those with which the vehicle is not required to conform because of—

- (a) an exemption under the Heavy Vehicle National Law (Queensland); or
- (b) a guideline or permit under the Vehicle Standards and Safety Regulation.

## **6 Registered and unregistered vehicles**

- (1) In this regulation, a vehicle is taken to be a registered vehicle if it has current registration under this regulation.
- (2) In this regulation, a vehicle is taken to be an unregistered vehicle if—
  - (a) it has no current registration under this regulation because—
    - (i) it has never had registration under this regulation; or
    - (ii) it has had registration under this regulation, but the registration has expired or been cancelled; and
  - (b) nothing in this regulation permits its use on a road, whether or not under limited circumstances.

# **Part 2 Registration principles**

## **7 Garage address in Queensland**

A vehicle may be registered in Queensland only if its garage address is in Queensland.

---

## **8 Persons eligible to register vehicle**

- (1) A person may apply to the chief executive to register a category 1 vehicle in the person's name.
- (2) A person may apply to the chief executive to register a category 2 vehicle in the person's name only if the person is a corporation or an individual aged 18 or over.

## **9 Registration and conditional registration**

- (1) A vehicle is eligible for registration under this regulation if it conforms with the requirements applying to the vehicle under a vehicle law.
- (2) However, if the chief executive is authorised under section 12 to conditionally register a vehicle, it is not eligible for registration other than conditional registration.
- (3) An unregistered vehicle that the chief executive is authorised to conditionally register under section 12 can be the subject of an authorisation under section 107 or 108 for it to be used on a road, but it can not be the subject of an unregistered vehicle permit under section 60.

## **10 Proof of compliance with vehicle law**

- (1) The chief executive may accept as evidence that a vehicle conforms with the requirements applying to the vehicle under a vehicle law—
  - (a) a plate attached to the vehicle under the vehicle law; or
  - (b) a written statement from the vehicle's manufacturer stating that the vehicle conforms with the requirements applying to the vehicle under a vehicle law.
- (2) In the absence of evidence mentioned in subsection (1), the chief executive may, on inspecting the vehicle and being satisfied it conforms with the requirements applying to the vehicle under a vehicle law, issue a certificate to that effect.

## **Part 3                      Vehicle registration**

### **Division 1                      Vehicles used on roads must be registered**

#### **11                      Vehicles used on roads must be registered**

A person must not use, or permit to be used, on a road a vehicle that is not a registered vehicle unless—

- (a) the vehicle is being driven or towed under section 15; or
- (b) the vehicle is being brought to the chief executive under section 16; or
- (c) the vehicle is being used under an unregistered vehicle permit; or
- (d) the vehicle is being used under the authority of a dealer plate under section 62; or
- (e) the vehicle is being used under section 105; or
- (f) the vehicle is being used under section 105A; or
- (g) the vehicle is being used under an authorisation issued under section 107; or
- (h) the vehicle is being used under a permit issued under section 108; or
- (i) the vehicle is an exempt vehicle.

Maximum penalty—80 penalty units.

### **Division 2                      Conditional registration**

#### **12                      Conditional registration**

- (1) This section applies to a vehicle if the safe movement guideline or heavy vehicle standards exemption applies to the vehicle.



- 
- (2) The chief executive may, on application under section 13, register the vehicle (*conditional registration*) with 1 of the following—
    - (a) limited access registration;
    - (b) zone access registration;
    - (c) unrestricted access registration.
  - (3) However, the chief executive must not register the vehicle unless the chief executive is satisfied the vehicle conforms with the safe movement guideline or heavy vehicle standards exemption.
  - (4) If this section applies to a vehicle because of the safe movement guideline and the chief executive registers the vehicle under subsection (2), a person must not permit the vehicle to be used on a road unless the conditions for use applying to the vehicle stated in the safe movement guideline allow the vehicle to be used on the road.

Maximum penalty—30 penalty units.

## **Division 3                      Registration generally**

### **13            Application for registration**

- (1) An application for the registration of a vehicle must be made to the chief executive and be accompanied by the following—
  - (a) any vehicle registration fee under schedule 1 or 2 for the vehicle;
  - (b) any registration administration fee for a conditionally registered vehicle under schedule 3 for the vehicle;
  - (c) any plate fee under schedule 3 for the vehicle;
  - (d) if the vehicle is a category 1 vehicle—the traffic improvement fee under schedule 3 for the vehicle;

[s 13]

---

- (e) if the vehicle is a category 2 vehicle, other than a trailer—the registration administration fee under schedule 3 for the vehicle;
- (f) any insurance certificate required under the *Motor Accident Insurance Act 1994* for the vehicle for the proposed registration term or the insurance premium payable under that Act for the certificate;
- (g) if the vehicle is a COI vehicle under the Vehicle Standards and Safety Regulation, prescribed evidence of a current certificate of inspection under that regulation for the vehicle, but only if, once the vehicle is registered, its owner will be required under that regulation to possess a current certificate of inspection for the vehicle;
- (h) if the vehicle is an SC vehicle under the Vehicle Standards and Safety Regulation, prescribed evidence of a current safety certificate under that regulation, unless—
  - (i) the garage address of the vehicle is in an area mentioned in the Vehicle Standards and Safety Regulation, schedule 2; or
  - (ii) both of the following apply—
    - (A) the vehicle has never previously been registered in Queensland, in another State or in a foreign country;
    - (B) when the application is made, the vehicle's odometer reads a distance of not more than 500km; or
  - (iii) the vehicle is being registered in the name of a dealer for resale purposes;
- (i) any duty payable under the *Duties Act 2001*;
- (j) if applicable, a gas certificate for each gas system in the vehicle;
- (k) if the applicant is relying on section 100C or 100D—the evidence or notice required under section 100E.

*Notes—*

- 1 See sections 19J and 19L of the Act, for the requirement for an application to be accompanied by a statutory declaration in particular circumstances.
  - 2 See part 10, division 3A, subdivision 2 for requirements about the application.
- (2) However, subsection (1)(e) does not apply to a category 2 vehicle if another registration administration fee applies to the vehicle under subsection (1).

#### **14 Registration application made by agent**

- (1) This section applies if the application of a person (the *applicant*) to register a vehicle is made by another person (the *agent*) as agent for the applicant.
- (2) The chief executive must not grant the application unless the agent gives the chief executive satisfactory evidence of—
  - (a) the agent’s identity; and
  - (b) the applicant’s identity; and
  - (c) the agent’s authority to act as agent for the applicant to register the vehicle.

#### **15 Driving or towing unregistered vehicle**

- (1) A person may drive or tow an unregistered vehicle on a road to any of the places mentioned in subsection (2), or for the testing mentioned in subsection (3), if—
  - (a) it is necessary for, or reasonably connected with, registering the vehicle under this regulation; and
  - (b) for a vehicle that is required to be insured under the *Motor Accident Insurance Act 1994*—a current insurance certificate has been issued for the vehicle and is carried—
    - (i) for a trailer—in the motor vehicle towing the trailer; or

[s 16]

---

(ii) for another vehicle—in the vehicle.

*Note—*

See also section 64(1A).

- (2) For subsection (1), the places are as follows—
- (a) an AIS, if the vehicle is driven or towed to the AIS for inspection for the purpose of obtaining an inspection certificate under the Vehicle Standards and Safety Regulation;
  - (b) a written-off vehicle inspection site, if the vehicle is recorded in the register as a repairable write-off and it is driven or towed to the site for the purpose of obtaining a written-off vehicle inspection report;
  - (c) the vehicle's garage address;
  - (d) an office of the chief executive, if the vehicle is driven or towed to the office to register the vehicle;
  - (e) another place, if the chief executive requires the vehicle to be taken to the place.
- Examples for paragraph (e)—*
- a place for inspecting by the Queensland Police Service
  - a place for having an identifying number stamped
  - a place for obtaining a gas certificate
  - a weighbridge for obtaining a measurement ticket
- (3) For subsection (1), the person may drive or tow the vehicle for testing to confirm the safe operation of the vehicle as part of an inspection mentioned in subsection (2)(a).

## 16 Vehicle inspections

- (1) The chief executive may require a vehicle to be brought to the chief executive for an inspection—
- (a) before the vehicle is registered under this regulation; or
  - (b) if the vehicle is recorded in the register as a repairable write-off, before the chief executive changes the register

---

to ensure the vehicle is no longer recorded as a repairable write-off.

- (2) Subsection (3) applies if, when the chief executive inspects the vehicle—
  - (a) an identifying number placed on the vehicle by the vehicle's manufacturer is not clearly legible or appears to have been altered or defaced; or
  - (b) for a vehicle recorded in the register as a repairable write-off that has been repaired, the vehicle no longer has an identifying number.
- (3) The chief executive—
  - (a) may allot a replacement identifying number for the vehicle; and
  - (b) must record the allotted replacement identifying number in the register.
- (4) If the vehicle is a motor vehicle, the applicant must, as soon as practicable—
  - (a) take action to obtain the necessary permission mentioned in section 134 of the Act to stamp the allotted replacement identifying number on the vehicle; and
  - (b) if the permission is obtained, ensure the allotted replacement identifying number is stamped on the vehicle.

Maximum penalty—8 penalty units.

- (5) The obligation to which the applicant is subject under subsection (4) continues to apply even if the applicant does not further pursue the registration of the vehicle.
- (6) Subsection (7) applies if, after the vehicle is registered or, for a vehicle that was recorded in the register as a repairable write-off, after the chief executive has changed the register to ensure the vehicle is no longer recorded as a repairable write-off, it appears to the chief executive that there is a possible discrepancy relating to the particulars of the vehicle as registered.

[s 17]

---

- (7) The registered operator of the vehicle must, if requested by written notice from the chief executive, return the vehicle for further inspection.

Maximum penalty for subsection (7)—8 penalty units.

## **17 Deciding applications**

- (1) The chief executive may refuse an application for the registration of a vehicle if the chief executive reasonably believes—
- (a) information given in the application is false or misleading; or
  - (b) the vehicle's chassis number or VIN is the same as the chassis number or VIN of a vehicle recorded in the register, or in a register kept under a corresponding law to this regulation, as a statutory write-off; or
  - (c) the vehicle's chassis number or VIN is the same as the chassis number or VIN of a vehicle recorded in the register as a repairable write-off, unless there is a written-off vehicle inspection report for the vehicle; or
  - (d) the vehicle's chassis number or VIN is the same as the chassis number or VIN of a vehicle recorded in a register kept under a corresponding law to this regulation as a repairable write-off, unless there is a written-off vehicle inspection report for the vehicle or, under the corresponding law, there is a report for the vehicle that is equivalent to a written-off vehicle inspection report; or
  - (e) a person, by giving or purporting to give under this regulation a written-off vehicle inspection report for the vehicle, has committed an offence; or
  - (f) a person, by giving or purporting to give under a corresponding law to this regulation a report that is equivalent to a written-off vehicle inspection report for the vehicle, has committed an offence; or

- 
- (g) an approved examiner has, by issuing an inspection certificate for the vehicle under the Vehicle Standards and Safety Regulation, contravened the Act; or
  - (h) there are unpaid fines or penalties arising out of the use of the vehicle in Queensland or another State; or
  - (i) the vehicle's garage address is in another State; or
  - (j) the vehicle does not conform with the requirements applying to the vehicle under a vehicle law; or
  - (k) the vehicle has been registered in another State and—
    - (i) the registration in the other State has been suspended or cancelled for a reason other than its expiry; and
    - (ii) the reasons for the cancellation or suspension still exist; or
  - (l) all of the following apply—
    - (i) the vehicle is a heavy vehicle;
    - (ii) a court has made an order against a person under the Heavy Vehicle National Law (Queensland), section 598(2) cancelling the registration of the vehicle;
    - (iii) the court has also, under section 598(3) of that Law, made an order that the person, or an associate of the person, is disqualified from applying for the registration of the vehicle for a stated period;
    - (iv) the applicant for registration is, under the order mentioned in subparagraph (iii), currently disqualified from applying for registration of the vehicle.
- (1A) The chief executive must refuse an application for the registration of a vehicle if the chief executive reasonably believes the vehicle or a part of the vehicle is, or may be, stolen.
- (1B) The chief executive may refuse an application for the registration of a vehicle if all of the following apply—

[s 17]

---

- (a) the vehicle, or a part of the vehicle, is subject to the *Consumer Goods (Motor Vehicles With Affected Takata Airbag Inflators and Specified Spare Parts) Recall Notice 2018* (Cwlth) (the **recall notice**);
  - (b) the ACCC gives the chief executive written advice that—
    - (i) the supplier of the vehicle is considered to have complied with its obligations to replace affected airbag inflators under the recall notice; and
    - (ii) an affected airbag inflator fitted within the vehicle has not been replaced in compliance with the recall notice;
  - (c) the chief executive reasonably believes that each affected airbag inflator fitted within the vehicle has not been replaced in compliance with the recall notice.
- (2) Subsections (1), (1A) and (1B) do not limit the chief executive’s power to refuse the application under another provision of this regulation.
- (3) Despite subsection (1), the chief executive may decide that a written-off vehicle inspection report is not required for a vehicle that is recorded in the register, or in a register kept under a corresponding law to this regulation, as a repairable write-off.

*Example—*

The chief executive decides the damage to a vehicle is limited to cosmetic damage.

- (4) If the chief executive decides to grant the application, the chief executive must register the vehicle in the applicant’s name.
- (5) If the chief executive decides to refuse the application, the chief executive must tell the applicant—
  - (a) the reasons for the refusal; and
  - (b) that the decision may be reviewed under section 111, unless—



- 
- (i) the vehicle's chassis number or VIN is the same as the chassis number or VIN of a vehicle recorded in the register, or in a register kept under a corresponding law to this regulation, as a statutory write-off; or
  - (ii) the chief executive has refused the application under subsection (1A).
- (6) If asked by the applicant, the chief executive must give written reasons for refusing the application.
- (7) This section is subject to section 109D(4) and (5).

## 18 Registered vehicles register

- (1) The chief executive must keep a register of registered vehicles (the *register*).
- (2) The register must contain the following particulars for each registered vehicle, to the extent the particulars are applicable for the vehicle—
  - (a) the registered operator's name;
  - (b) the vehicle's registration number and other identification details, including the vehicle's description;
  - (c) the vehicle's GVM and, if applicable, GCM;
  - (d) the vehicle's garage address;
  - (e) the registered operator's address;
  - (f) if there is a current postal address for the registered operator—the postal address;
  - (g) the vehicle's purpose of use, for example, private use or farm use;
  - (h) for a conditionally registered vehicle that is not a heavy vehicle, the conditions for use applying to the vehicle that are stated in the safe movement guideline;

[s 18]

---

- (i) for a conditionally registered vehicle that is a heavy vehicle, the conditions stated in the heavy vehicle standards exemption;
  - (j) the commencement and expiry days for the registration;
  - (k) for a category 2 vehicle—the vehicle’s nominated configuration;
  - (l) for a motorbike, other than a motorbike that is conditionally registered—whether the motorbike is a learner approved motorbike.
- (3) The chief executive must ensure the register contains the particulars of each vehicle that—
- (a) is currently registered; or
  - (b) is not currently registered, but has been a registered vehicle within the previous 2 years.
- (4) The register must also contain the notifiable information about a written-off vehicle notified under part 8, whether or not the vehicle is currently registered.
- (5) However, subsection (6) applies if—
- (a) for a vehicle recorded in the register as a repairable write-off, there is a written-off vehicle inspection report for the vehicle; or
  - (b) for a vehicle recorded in a register kept under a corresponding law to this regulation, there is under the corresponding law a report for the vehicle that is equivalent to a written-off vehicle inspection report.
- (6) The chief executive must change the register to ensure the vehicle is no longer recorded as a repairable write-off.
- (7) The chief executive may record in the register other information—
- (a) required to be recorded under the Act or another Act; or
  - (b) the chief executive decides is appropriate.

---

*Examples of information the chief executive may record under paragraph (b)—*

- odometer readings to help in consumer protection
  - pension details for implementing the provisions of this regulation about concessional registration fees
  - information about a written-off vehicle given to the chief executive by the Queensland Police Service, the police service of another State, a corresponding authority or a notifier under a corresponding law to this regulation
- (8) Despite anything else in this regulation—
- (a) the chief executive is not required to ensure the person whose name is shown in the register as the registered operator of a vehicle is a person who has title to the vehicle; and
  - (b) the register is not intended to be a means by which the title to a registered vehicle may be conclusively established.

## **19 Registration certificates**

- (1) If the chief executive registers a vehicle, the chief executive must issue a registration certificate to the applicant for the vehicle.
- (2) The certificate must include the following particulars, to the extent the particulars are applicable for the vehicle—
  - (a) the registered operator's name and address;
  - (b) the vehicle's garage address;
  - (c) the vehicle's registration number;
  - (d) the make of the vehicle;
  - (e) the vehicle's VIN or, if there is no VIN, the vehicle's chassis number or engine number;
  - (f) the vehicle's GVM and, if applicable, GCM;
  - (g) the vehicle charging category under part 11, division 1;
  - (h) the commencement and expiry days for the registration;

[s 20]

---

- (i) if the vehicle is a conditionally registered vehicle that is not a heavy vehicle—
    - (i) the conditions for use applying to the vehicle that are stated in the safe movement guideline; and
    - (ii) a separate code, for example a letter of the alphabet, for each of the conditions;
  - (j) if the vehicle is a conditionally registered vehicle that is a heavy vehicle—
    - (i) the conditions stated in the heavy vehicle standards exemption; and
    - (ii) a separate code, for example a letter of the alphabet, for each of the conditions.
- (3) The chief executive may also include in the certificate any other information the chief executive decides is appropriate.

## **20 Registered operator to notify change of particulars**

- (1) The registered operator of a vehicle must give the chief executive notice of any of the following changes within 14 days of the change—
- (a) a change of the operator’s address;
  - (b) if there is a current postal address for the operator—a change of the postal address;
  - (c) a change of the garage address of the vehicle;
  - (d) a change of the purpose of use of the vehicle.

Maximum penalty—8 penalty units.

*Note—*

See part 10, division 3A, subdivision 3 for requirements about the notice.

- (2) The registered operator of a vehicle must, within 14 days after the person’s name is changed, give the chief executive—
- (a) notice of the change; and

*Note—*

See part 10, division 3A, subdivision 3 for requirements about the notice.

- (b) written material, satisfactory to the chief executive, evidencing the change.

Maximum penalty—8 penalty units.

- (3) If a person modifies a registered vehicle, the registered operator of the vehicle must give the chief executive notice of the modification within 14 days after the modification.

Maximum penalty—8 penalty units.

*Note—*

See part 10, division 3A, subdivision 3 for requirements about the notice.

- (4) The registered operator must not use the vehicle on a road until the chief executive has been notified of the modification, and any additional registration fee or charge attributable to the modification has been paid to the chief executive, if—

- (a) the vehicle is a category 2 vehicle; and
- (b) at least 1 of the following applies—
  - (i) the modification is to the vehicle's description as recorded in the register;
  - (ii) because of the modification, the registration fee applicable to the vehicle is higher than the fee paid for its current registration.

Maximum penalty—80 penalty units.

- (5) In this section—

***modifies a registered vehicle*** means modifies any of the following—

- (a) the vehicle's axle configuration;
- (b) the vehicle's carrying capacity;
- (c) the vehicle's description as recorded in the register;
- (d) the method of propulsion of the vehicle;

[s 21]

---

- (e) the vehicle's GCM or GVM;
- (f) any other particular of the vehicle recorded in the register.

## **21 Recording change in vehicle particulars and reassessment of registration fee**

- (1) If the chief executive is satisfied the particulars given under section 20 are correct, the chief executive must—
  - (a) record the correct name, address, postal address, purpose of use or other particulars in the register; and
  - (b) issue an updated registration certificate.
- (2) However, the chief executive must not act under subsection (1) to record an identifying number of a vehicle that is recorded in the register as a written-off vehicle, other than if the chief executive allots a replacement identifying number for the vehicle under section 16.
- (3) Also, if the particulars are for a change to a vehicle's purpose of use or the modification of a vehicle under section 20(5), the chief executive may reassess the registration fee payable for the vehicle for the term (the *unexpired term*) calculated from when the purpose of use changed or the vehicle was modified to the end of the vehicle's current registration.
- (4) The chief executive must as soon as practicable refund to the registered operator any amount by which the reassessed fee is less than the fee already paid for the unexpired term.
- (5) The chief executive may, by written notice given to the registered operator, require the registered operator to pay any amount by which the reassessed fee is more than the fee already paid for the unexpired term within 28 days after the notice is given.
- (6) The registered operator must comply with the requirement unless the registered operator has a reasonable excuse.

Maximum penalty for subsection (6)—60 penalty units.

## 22 Registration term

Subject to sections 23, 97 and 100C, a vehicle may be registered for the term asked for by the applicant that is 1 of the following terms—

- (a) 1 year;
- (b) 6 months;
- (c) 3 months, if—
  - (i) the vehicle is a category 2 vehicle; or
  - (ii) the vehicle is used to provide a taxi service or a booked hire service within the meaning of the *Transport Operations (Passenger Transport) Act 1994*; or
  - (iii) the applicant agrees to the matters mentioned in paragraph (d)(i) and (ii);
- (d) 1 month, if—
  - (i) the applicant agrees to pay the registration-related amount and any surcharge payable for the renewal of the registration of the vehicle under a direct debit arrangement; and
  - (ii) the applicant agrees to receive all communication in relation to the registration and renewal of the registration of the vehicle electronically;
- (e) any term, including a term mentioned in paragraph (c) or (d), if the chief executive considers the term reasonable and appropriate.

## 23 Seasonal registration

- (1) A prescribed vehicle owned by a primary producer may be registered for 3 or 6 months if it is used only in the registered operator's business as a primary producer.
- (2) A prescribed vehicle used only seasonally may be registered for 3 or 6 months if it is used only to transport primary

[s 24]

---

produce from a farm or fishing waters to where the primary produce is—

- (a) loaded onto a train, vessel or another vehicle; or
  - (b) stored before being processed; or
  - (c) the subject of the first processing step applied to it; or
  - (d) processed.
- (3) Subject to sections 99 and 100F, at the end of the registration term, the registration of a prescribed vehicle under subsection (1) or (2) may be—
- (a) renewed for 3 months or 6 months; or
  - (b) deferred for a period of not longer than 1 year, and renewed during, or at the end of, the period.
- (4) Subsection (3) does not stop the registration of a prescribed vehicle being—
- (a) renewed for a term for which prescribed vehicles are usually registered under section 22; or
  - (b) cancelled under part 6.

## **24 When registration becomes effective**

The registration of a vehicle is effective on the issue of the chief executive's receipt for payment of the relevant fees payable, in relation to the registration, under this regulation.

## **Division 4 Approval of motorbikes as learner approved motorbikes**

### **25 Purpose of div 4**

The purpose of this division is to enable a person to apply to the chief executive for the approval of a particular motorbike as a learner approved motorbike.



---

*Note—*

This application process may be used if a particular bike is not stated to be a learner approved motorbike in the list of learner approved motorbikes kept by the chief executive.

## 26 Definition for div 4

In this division—

**LAM information**, for a motorbike, means the following information about the motorbike—

- (a) engine capacity;
- (b) maximum engine power;
- (c) tare mass.

## 27 Meaning of **LAM test report**

- (1) A **LAM test report** is documentation showing the results of 1 or more tests conducted on a motorbike to work out the LAM information for an application for approval of the motorbike under section 28.

*Example of LAM test report—*

a printout of the results of a test from a vehicle testing facility and a printout of the results of a test by a weighbridge

- (2) A test mentioned in subsection (1) may be conducted by 1 or more entities.
- (3) A LAM test report must contain the following information about a test conducted on a motorbike—

- (a) the name and address of the entity that conducted the test;

*Example of an entity for paragraph (a)—*

an entity that operates a vehicle testing facility or a weighbridge

- (b) the date of the test;
- (c) the LAM information;

[s 28]

---

- (d) details about the measuring system used to conduct the test.

*Example of a measuring system for paragraph (d)—*

a dynamometer or a similar measuring system that is designed to measure power produced by an engine

## 28 **Application for approval of motorbike as a learner approved motorbike**

- (1) A person may apply to the chief executive for approval of a production motorbike as a learner approved motorbike.

*Note—*

See part 10, division 3A, subdivision 2 for requirements about the application.

- (2) The application must—
- (a) be accompanied by—
- (i) a copy of a document (the *manufacturer's document*) published by the motorbike's manufacturer showing the LAM information for the motorbike; or
- (ii) if a copy of the manufacturer's document is unavailable or does not provide the LAM information for the motorbike—a LAM test report; and
- (b) to the extent the information is available to the applicant, include the following information about the motorbike—
- (i) make and model;
- (ii) year of manufacture;
- (iii) engine number;
- (iv) VIN or chassis number.
- (3) Subject to section 109D(4) and (5), the chief executive may grant the application only if the chief executive is satisfied that—

- 
- (a) for a motorbike with an internal-combustion engine—the engine capacity for the motorbike is not more than 660mL; and
  - (b) the power-to-weight ratio for the motorbike is not more than 150kW per tonne; and
  - (c) any modifications to the motorbike are allowable modifications.
- (4) If the chief executive decides to grant the application, the chief executive must—
    - (a) record the motorbike in the register as a learner approved motorbike; and
    - (b) record the motorbike in the list of learner approved motorbikes kept by the chief executive.
  - (5) However, the chief executive is not required to record the motorbike in the register under subsection (4)(a) if the motorbike is conditionally registered.
  - (6) If the chief executive decides to refuse the application, the chief executive must tell the applicant—
    - (a) the reasons for the refusal; and
    - (b) that the decision may be reviewed under section 111.
  - (7) If asked by the applicant, the chief executive must give written reasons for refusing the application.

## **Division 5                      Number plates**

### **29            Chief executive to assign registration number and issue number plates**

- (1) If the chief executive registers a vehicle, the chief executive must—
  - (a) assign a distinguishing registration number to the vehicle; and
  - (b) issue to the registered operator of the vehicle—

[s 30]

---

- (i) if the vehicle is a motorbike, motorised wheelchair, quad bike or trailer—1 number plate displaying the assigned number; or
  - (ii) if the vehicle is a vehicle other than a vehicle mentioned in subparagraph (i)—2 number plates displaying the assigned number.
- (2) However, subsection (1) does not apply if—
  - (a) the vehicle is a category 2 vehicle; and
  - (b) on receipt of the application for registration of the vehicle—
    - (i) the vehicle is registered in another State under a corresponding law to this regulation; and
    - (ii) the person making the application is the person in whose name the vehicle is registered under the corresponding law to this regulation; and
    - (iii) the current number plate for the vehicle is a national heavy vehicle number plate.

### **30 Position, visibility and legibility of number plate**

- (1) The registered operator of a vehicle must ensure that each number plate issued for the vehicle, or a special plate attached to a vehicle, is securely attached to the vehicle so that, if the vehicle is on level ground—
  - (a) the number plate is—
    - (i) in an upright position parallel to the vehicle's axles; and
    - (ii) not more than 1.3m above ground level; and
  - (b) unless an accessory plate is attached to the vehicle in the way required under section 37—the characters on the number plate are visible from 20m away at any point within an arc of 45° from the surface of the number plate above or to either side of the vehicle, in the way shown in figures 1 and 2 at the end of this section; and

- 
- (c) any cover on the number plate—
    - (i) is clear, clean, untinted and flat over its entire surface; and
    - (ii) has no reflective or other characteristics that would prevent—
      - (A) the successful operation of a photographic detection device; or
      - (B) the number plate from being legible; and
  - (d) the number plate is in a clearly legible condition, including being clearly legible from any position from which it is required to be visible.

Maximum penalty—40 penalty units.

- (2) A load on the vehicle is taken to make the characters not visible contrary to subsection (1)(b) if the load—
  - (a) makes the characters not visible or only partly visible; or
  - (b) obscures the characters.
- (3) The registered operator must also ensure that—
  - (a) if the vehicle has been issued with 2 number plates or 2 special plates are to be attached to the vehicle—1 number plate is attached to the front of the vehicle and the other to its rear; or
  - (b) if the vehicle has been issued with only 1 number plate or only 1 special plate is to be attached to the vehicle—the number plate is attached to its rear.

Maximum penalty—12 penalty units.

- (4) The registered operator does not contravene subsection (1)(a) or (b) if—
  - (a) it is not practicable to attach a number plate to the vehicle in the way required under subsection (1)(a) or (b) because of the vehicle's construction; and

[s 30]

---

- (b) the registered operator attaches the number plate to the vehicle as nearly as practicable in the way required under subsection (1)(a) or (b).
- (5) The registered operator does not contravene subsection (1)(b) if the position for the rear number plate of the vehicle (the **towing vehicle**) is obscured by another vehicle (the **towed vehicle**) being towed by the towing vehicle and any of the following applies—
- (a) the towed vehicle is registered under this regulation or a corresponding law to this regulation, and displays its rear number plate in the way required under subsection (1) or under the corresponding law;
  - (b) the towing vehicle is a tow truck, the towed vehicle is not registered under this regulation or a corresponding law to this regulation, and the towed vehicle—
    - (i) displays the towing vehicle’s rear number plate in a way consistent with the requirements of subsection (1); or
    - (ii) displays an accessory plate for the towing vehicle in the way required under section 38(5);
  - (c) the towing vehicle is not a tow truck, the towed vehicle is an exempt vehicle under section 4(a), (b) or (l) when being towed by the towing vehicle and the towed vehicle displays the towing vehicle’s rear number plate in a way consistent with the requirements of subsection (1) or under a corresponding law to this regulation.
- (6) If a vehicle’s number plates are removed and confiscated under the *Police Powers and Responsibilities Act 2000*, section 74H, the vehicle’s registered operator does not contravene subsection (1) or (3) while the number plates are confiscated.
- (7) In this section—
- number plate** does not include an accessory plate issued under section 37.
- photographic detection device** see section 113 of the Act.

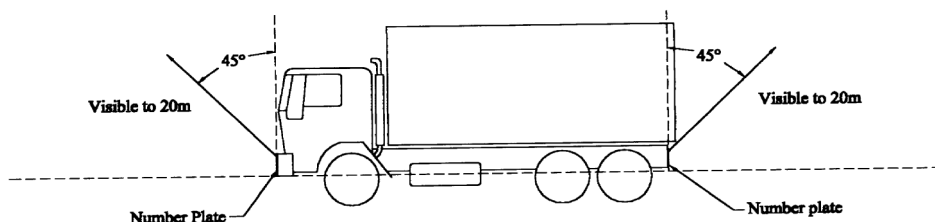

Figure 1

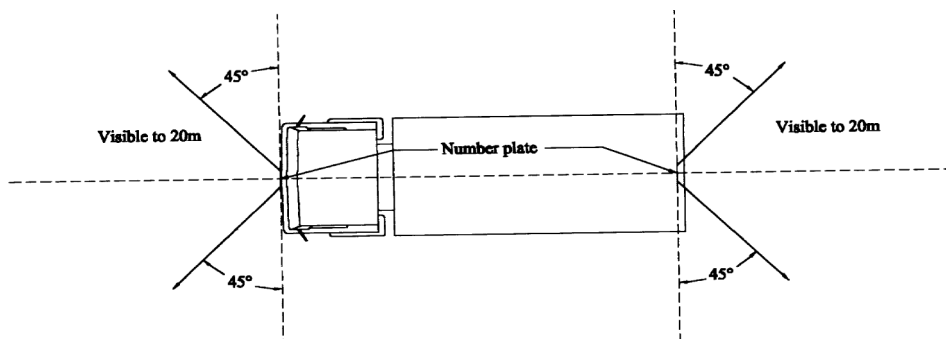

Figure 2

### 31 Time for attaching number plates

- (1) The registered operator of a vehicle must attach to the vehicle a number plate issued for the vehicle within 1 day after receiving the number plate.

Maximum penalty—12 penalty units.

- (2) The registered operator of a vehicle must attach to the vehicle a special plate the registered operator holds for the vehicle within 1 day after receiving a registration certificate for the vehicle showing the number of the special plate as the registration number of the vehicle.

Maximum penalty—12 penalty units.

### 32 Q plates

- (1) A person must not manufacture a replacement Q plate unless the person—

[s 32A]

---

- (a) has written approval from the chief executive to manufacture the plate; and
- (b) manufactures the plate under the specifications for the plate stated in the approval.

Maximum penalty—12 penalty units.

- (2) A replacement Q plate manufactured under subsection (1) is taken to have been issued by the chief executive.
- (3) In this section—

*Q plate* means a number plate the number of which consists of the letter ‘Q’ followed by at least 1, but not more than 6, figures.

### **32A Special edition number plates**

The chief executive may issue a special edition number plate for a vehicle, other than a category 2 vehicle, on receipt of an amount decided by the chief executive.

*Note—*

The amount mentioned in this section is in addition to any plate fee under schedule 3.

### **32B Application to replace number plate with special edition number plate**

- (1) The registered operator of a vehicle, other than a category 2 vehicle, may apply to the chief executive to replace the number plate for the vehicle with a special edition number plate.

*Note—*

See part 10, division 3A, subdivision 2 for requirements about the application.

- (2) The application must be accompanied by—
  - (a) any plate fee under schedule 3 for the vehicle; and
  - (b) the amount mentioned in section 32A; and



- 
- (c) the number plate previously issued for the vehicle, unless the plate is a personalised number plate or customised number plate.
- (3) On receipt of the application, the chief executive may—
    - (a) issue a special edition number plate to replace the number plate previously issued for the vehicle; and
    - (b) issue an updated registration certificate.
  - (4) If the chief executive issues a special edition number plate, on the issue of the plate—
    - (a) the number plate previously issued for the vehicle stops being effective; and
    - (b) the special edition number plate becomes the current number plate for the vehicle.

### **32C Application to replace number plate with national heavy vehicle number plate**

- (1) The registered operator of a category 2 vehicle may apply to the chief executive to replace the number plate for the vehicle with a national heavy vehicle number plate.

*Note—*

See part 10, division 3A, subdivision 2 for requirements about the application.

- (2) The application must be accompanied by—
  - (a) any plate fee under schedule 3, part 1 for the vehicle; and
  - (b) the number plate previously issued for the vehicle, unless the plate is a personalised number plate or customised number plate.
- (3) On receipt of the application, the chief executive may—
  - (a) issue a national heavy vehicle number plate to replace the number plate previously issued for the vehicle; and
  - (b) issue an updated registration certificate.

[s 33]

---

- (4) If the chief executive issues a national heavy vehicle number plate, on the issue of the plate—
  - (a) the number plate previously issued for the vehicle stops being effective; and
  - (b) the national heavy vehicle number plate becomes the current number plate for the vehicle.

### **33 Personalised number plates**

- (1) A person may apply to the chief executive for the issue of a personalised number plate.

*Note—*

See part 10, division 3A, subdivision 2 for requirements about the application.

- (1A) Subject to section 109D(4) and (5), the chief executive may issue the number plate as a personalised number plate on receipt of—
  - (a) the application; and
  - (b) an amount decided by the chief executive.
- (1B) Also, the chief executive may issue a number plate as a personalised number plate on a sale at public auction for an amount acceptable to the chief executive.
- (2) When the chief executive issues a personalised number plate, the chief executive must—
  - (a) assign a registration number to the person to whom the plate is issued; and
  - (b) record information relating to the plate in the register; and
  - (c) issue to the applicant a registration certificate for the plate stating the particulars of the plate.
- (3) The right to use the number on a personalised number plate issued to a person is the property of the person to whom the plate is issued.
- (4) A personalised number plate may be—

- 
- (a) kept without being attached to a vehicle; or
  - (b) subject to subsection (5), attached to a vehicle; or
  - (c) surrendered to the chief executive for cancellation.
- (5) A person must not attach a personalised number plate to a vehicle until the person has—
- (a) given the chief executive a notice of the person's intention to attach the number plate to the vehicle; and

*Note—*

See part 10, division 3A, subdivision 3 for requirements about the notice.

- (b) received a registration certificate for the vehicle showing the number of the number plate as the registration number for the vehicle.

Maximum penalty—12 penalty units.

- (6) A personalised number plate must be attached to a vehicle under any directions given by the chief executive.

Maximum penalty—12 penalty units.

- (7) The chief executive must not issue a personalised number plate if the number of the plate is identical, or appears to be identical, to the number of another number plate that is currently issued.
- (8) Subsection (3) does not apply if the personalised number plate is—
- (a) surrendered to the chief executive for cancellation under subsection (4)(c); or
  - (b) returned to the chief executive under section 102 or 103; or
  - (c) delivered to an authorised officer under section 128(1)(d); or
  - (d) under section 128A, removed and recovered by an authorised officer on the basis that it is required to be returned to the chief executive under section 102.

[s 34]

---

### **34 Transfer of personalised number plate**

- (1) A personalised number plate, including the right to use the number on the personalised number plate, is transferable.
- (2) A person to whom a personalised number plate is transferred, including a person administering a deceased estate, must within 14 days after the transfer—
  - (a) give the chief executive notice of the transfer; and

*Note—*

See part 10, division 3A, subdivision 3 for requirements about the notice.

- (b) pay the relevant fee.

Maximum penalty—16 penalty units.

- (2A) A person who transfers a personalised number plate to another person may give the chief executive notice of the transfer.

*Note—*

See part 10, division 3A, subdivision 3 for requirements about the notice.

- (2B) A person's obligation to act under subsection (2) for a personalised number plate is not affected if another person acts under subsection (2A) for the personalised number plate.

- (2C) Subsection (2D) applies if the chief executive—

- (a) receives—
      - (i) a notice and the fee under subsection (2); or
      - (ii) a notice under subsection (2A); and
    - (b) the chief executive is satisfied that the information stated in the notice in relation to the transfer of the personalised number plate is correct.

- (2D) The chief executive must—

- (a) record in the register the day of the transfer stated in the notice; and
    - (b) substitute the name and address of the person transferring the personalised number plate with the

name and address of the person acquiring the personalised number plate; and

- (c) amend the register to record the postal address, or lack of a postal address, for the person acquiring the personalised number plates.
- (3) A person must not transfer a personalised number plate on its own if it is one of a pair.

Maximum penalty—16 penalty units.

### 35 **Converting number plate to personalised number plate**

A person may, on payment of an amount decided by the chief executive, apply to the chief executive to convert a number plate, other than a national heavy vehicle number plate, to a personalised number plate.

*Note—*

See part 10, division 3A, subdivision 2 for requirements about the application.

### 36 **Customised number plates**

- (1) A person may apply to the chief executive to customise a vehicle's number plate, or a previously issued number plate, other than a personalised number plate.

*Note—*

See part 10, division 3A, subdivision 2 for requirements about the application.

- (2) A *customised number plate* is a number plate that a person may—
- (a) keep without attaching it to a vehicle; or
  - (b) subject to subsection (3), attach to a vehicle.
- (3) A person must not attach a customised number plate to a vehicle until the person has—
- (a) given the chief executive notice of the person's intention to attach the number plate to the vehicle; and

[s 37]

---

*Note—*

See part 10, division 3A, subdivision 3 for requirements about the notice.

- (b) received a registration certificate for the vehicle showing the number of the number plate as the registration number for the vehicle.

Maximum penalty for subsection (3)—12 penalty units.

### **37 Accessory plates**

- (1) A person may apply to the chief executive for an accessory plate for an accessory that is to be attached to a vehicle.

*Note—*

See part 10, division 3A, subdivision 2 for requirements about the application.

- (2) The accessory plate must display the same registration number as the number plate attached to the vehicle.
- (3) The application must be accompanied by the relevant fee.
- (4) If the chief executive decides to issue the accessory plate, the chief executive must issue the plate as soon as convenient after the plate has been prepared.
- (5) A person who attaches an accessory plate to the front of a vehicle must attach the plate—

- (a) at the front of the accessory; and
- (b) in a way that allows the accessory plate to be legible from a distance of at least 20m from the front of the accessory.

Maximum penalty—12 penalty units.

- (6) A person who attaches an accessory plate to the rear of a vehicle must attach the plate—
  - (a) at the rear of the accessory; and
  - (b) in a way that allows the accessory plate to be legible from a distance of at least 20m from the rear of the accessory.

Maximum penalty—12 penalty units.

(7) In this section—

**accessory** means a bike rack or other device attached to the front or rear of a vehicle in a way that—

- (a) makes the vehicle's front or rear number plate not visible or only partly visible; or
- (b) obscures the vehicle's front or rear number plate.

### **38 Accessory plate for tow truck**

(1) The registered operator of a tow truck may apply to the chief executive for an accessory plate to be attached to unregistered vehicles when towed by the tow truck.

*Note—*

See part 10, division 3A, subdivision 2 for requirements about the application.

- (2) The accessory plate must display the same registration number as each number plate for the tow truck.
- (3) The application must be accompanied by the relevant fee.
- (4) If the chief executive decides to issue the plate, the chief executive must issue the plate as soon as convenient after the plate has been prepared.
- (5) A person who attaches an accessory plate for a tow truck to an unregistered vehicle to be towed by the tow truck must attach it to the rearmost end of the vehicle, as towed, in a way that is as nearly as practicable in the same way a number plate would be required to be attached to that end of the vehicle were it a registered vehicle.

Maximum penalty for subsection (5)—12 penalty units.

### **39 When number plate must not be attached to a vehicle**

A number plate, other than a dealer plate, must not be attached to a vehicle if—

[s 42]

---

- (a) the registration of the vehicle has been cancelled and not renewed; or
- (b) it has been more than 3 months since the vehicle's registration expired and the registration has not been renewed.

*Note—*

See section 127(2)(h)(ii).

## Part 4                      **Renewal of registration**

### **42            Registration renewal notice**

- (1) A registration renewal notice (a *renewal notice*) for a registered vehicle is a notice sent by the chief executive—
    - (a) addressed to—
      - (i) if the vehicle's registered operator has given the chief executive a direction to address the notice to another person—the person; or

*Note—*

See part 10, division 3A, subdivision 3 for requirements about the direction.

    - (ii) otherwise—the vehicle's registered operator; and  - (b) stating that, if the vehicle's registration is not renewed on or before a stated day, it expires.
- (2) However, if the chief executive does not send, or the registered operator does not receive, a renewal notice, the non-receipt of the notice does not affect—
  - (a) the expiry of the vehicle's registration; or
  - (b) the registered operator's obligation to renew the vehicle's registration before it expires, if the registered operator intends to use the vehicle on a road after the existing registration expires.



### 43 Renewal of registration

- (1) A person may apply to the chief executive for renewal of a vehicle's registration.

*Note—*

See part 10, division 3A, subdivision 2 for requirements about the application.

- (1A) The application must be accompanied by the following—
- (a) any vehicle registration fee under schedule 1 or 2 for the vehicle;
  - (b) any registration administration fee for a conditionally registered vehicle under schedule 3 for the vehicle;
  - (c) if the vehicle is a category 1 vehicle—the traffic improvement fee under schedule 3 for the vehicle;
  - (d) if the vehicle is a category 2 vehicle, other than a trailer—the registration administration fee under schedule 3 for the vehicle;
  - (e) any insurance certificate required under the *Motor Accident Insurance Act 1994* for the vehicle for the proposed term of registration or the insurance premium payable under that Act for the certificate;
  - (f) if the vehicle is a COI vehicle under the Vehicle Standards and Safety Regulation—prescribed evidence of a current certificate of inspection under that regulation for the vehicle, but only if its owner is required under that regulation to possess a current certificate of inspection for the vehicle;
  - (g) if the applicant is relying on section 100C or 100D—the evidence or notice required under section 100E.
- (1B) However, subsection (1A)(d) does not apply to a category 2 vehicle if another registration administration fee applies to the vehicle under subsection (1A).
- (2) The applicant must nominate the registration term for the vehicle.

[s 43]

---

- (3) The registration term must be a term available under section 22 or 45 or permitted under section 23, 97 or 100C.
- (4) The registration of a vehicle may be renewed after its expiry—
  - (a) if the vehicle is registered for a term permitted under section 23—not more than 1 year after the expiry of the registration; or
  - (b) if section 99 or 100F applies—not more than 2 years after the expiry of the registration; or
  - (c) otherwise—not more than 3 months after the expiry of the registration.
- (5) Despite subsection (4), the chief executive may accept an application for renewal of registration at any time if the chief executive considers it reasonable in the circumstances to do so.
- (6) The expiry day of a renewed term of registration for a vehicle must be worked out as if the renewal had commenced—
  - (a) if the vehicle’s registration is deferred for a period under section 23(3)(b), 99(2) or 100F(2) and is renewed during, or at the end of, the period—the day after the day the deferral ended; or
  - (b) otherwise—on the day after the day recorded in the register as the expiry day of the registration being renewed.
- (7) Subsections (4) to (6) do not have the effect of retrospectively registering a vehicle.
- (8) If the period by which a vehicle’s registration may be renewed has ended but the registration has not been renewed, the chief executive may, by written notice given to the person who was recorded as the vehicle’s registered operator before the registration expired, require the person to return the vehicle’s number plates to the chief executive within 14 days after the notice is given.

- 
- (9) A person of whom a requirement is made under subsection (8) must not contravene the requirement, unless the person has a reasonable excuse.
- Maximum penalty—20 penalty units.
- (10) Despite subsections (1) to (9), or part 10, division 3A, subdivision 2, a person may renew a vehicle's registration using any of the ways stated in the renewal notice for the particular renewal.
- (11) Despite subsections (1) to (10), the chief executive—
- (a) may refuse an application for the renewal of the registration of a vehicle under the same circumstances, and in the same way, that the chief executive may refuse an application for the registration of a vehicle under section 17; and
  - (b) must refuse an application for the renewal of the registration of a vehicle if the chief executive reasonably believes the vehicle or a part of the vehicle is, or may be, stolen.

#### **44 When surcharge is payable for renewal**

- (1) This section applies if—
- (a) an applicant for renewal of registration for a vehicle is not required to pay a CTP insurance premium to the chief executive under section 43(1A)(e) in relation to the renewal; and
  - (b) the amount paid by the applicant for the purpose of the registration-related amount for the renewal is more than \$1 below what the registration-related amount would be if the relevant registration fee payable under section 43(1A)(a) for the renewal were for 1 year's registration.
- (2) This section also applies if—
- (a) an applicant for renewal of registration for a vehicle is required to pay a CTP insurance premium to the chief

[s 45]

---

- executive under section 43(1A)(e) in relation to the renewal; and
- (b) the amount paid by the applicant for the purpose of the registration-related amount for the renewal is more than \$1 below what the registration-related amount would be if—
    - (i) the relevant registration fee payable under section 43(1A)(a) for the renewal were for 1 year’s registration; and
    - (ii) the CTP insurance premium payable under section 43(1A)(e) in relation to the renewal were the lowest premium set by any CTP insurer for insurance covering 1 year’s registration.
- (3) The applicant under subsection (1) or (2) must pay the surcharge under schedule 3.

**45 Registration term if overpayment or underpayment of registration-related amount and any surcharge**

- (1) This section applies if an applicant for renewal of registration for a vehicle—
  - (a) does not present an insurance certificate under the *Motor Accident Insurance Act 1994* for the vehicle for the proposed term of registration to the chief executive under section 43(1A)(e); and
  - (b) overpays or underpays the total of the registration-related amount for the renewal and any surcharge payable for the renewal.
- (2) Despite section 22, the registration may be renewed for a term that is in proportion to the amount paid after deducting—
  - (a) any surcharge payable for the renewal under schedule 3; and
  - (b) any administrative fee for late payment payable for the renewal.

- 
- (3) However, the registration must not be renewed under subsection (2) if the amount paid is more than \$1 below what the total of the registration-related amount for the renewal and any surcharge payable under schedule 3 for the renewal would be if any CTP insurance premium, payable under section 43(1A)(e) in relation to the renewal, for the relevant registration term for the vehicle, were the lowest premium set by any CTP insurer.
  - (4) Also, if the amount paid is more than the registration-related amount for the renewal that would be payable if the registration were to be renewed for 14 months—
    - (a) the vehicle’s registration may only be renewed for 1 year; and
    - (b) the difference between the amount paid and the registration-related amount for the 1 year renewal must be refunded.
  - (5) If the term of registration would, other than for this subsection, not be a whole number of days—
    - (a) the term must be rounded down to the nearest whole day; and
    - (b) the difference between the amount paid and the total of the registration-related amount for the renewal and any surcharge payable for the renewal must be credited to the applicant.
  - (6) If subsection (3) applies, the chief executive must refund the amount paid to the applicant.
  - (7) The chief executive must—
    - (a) if subsection (3) applies—notify the applicant that the amount paid is being refunded because it is below the minimum amount required to enable renewal of registration; or
    - (b) otherwise—give the applicant, or otherwise make available to the applicant, a notice stating the term of registration for the vehicle.

#### **46 Administrative fee for late payment if cheque dishonoured**

- (1) This section applies if—
  - (a) payment for part or all of the amount payable for renewal of registration is made, before the expiry day of the registration, by cheque or other method of payment; and
  - (b) the cheque or payment is not honoured on presentation or is later dishonoured; and
  - (c) after the payment under paragraph (a), payment for part or all of the amount payable for the renewal is made after the expiry day of the registration.
- (2) In applying the administrative fee for late payment, the purported payment made before the expiry day must be disregarded.

#### **47 Issue of receipt and updating of records**

- (1) The renewal of the registration of a vehicle is effective—
  - (a) if the renewal involves the issue of the chief executive's receipt for payment before the expiry of the term of registration being renewed—immediately after the expiry of that term; or
  - (b) if the renewal does not involve the issue of the chief executive's receipt for payment but involves transactions that are completed before the expiry of the term of registration being renewed, including on the day of the expiry—immediately after the expiry of that term; or
  - (c) if the renewal involves the issue of the chief executive's receipt for payment after the expiry of the term of registration being renewed—on the issue of the chief executive's receipt for payment; or
  - (d) if the renewal does not involve the issue of the chief executive's receipt for payment but involves transactions that are completed after the expiry of the term of



[s 48]

---

Maximum penalty—16 penalty units.

*Note—*

See part 10, division 3A, subdivision 3 for requirements about the notice.

- (3A) If the dealer acquires the vehicle from another dealer (the ***disposing dealer***), subsection (3) does not apply if both dealers agree, in writing, that the disposing dealer will apply, or give notice, under subsection (6) within 14 days after the acquisition.
- (4) All amounts payable under subsection (2)(a) and (c) are payable by the person who acquires a vehicle from the day of the acquisition.
- (5) If a person who acquires a registered vehicle is unable to state the full name and address, or include the signature, of the person who sold or disposed of the vehicle in the application or notice, the person acquiring the vehicle must give a statement to that effect to the chief executive.

*Note—*

See part 10, division 3A, subdivision 3 for requirements about the statement.

- (6) If a person (the ***disposer***) disposes of a registered vehicle to someone else (the ***acquirer***), the disposer may—
- (a) apply to the chief executive for transfer of the vehicle's registration to the acquirer; or

*Note—*

See part 10, division 3A, subdivision 2 for requirements about the application.

- (b) give notice (a ***disposal notice***) to the chief executive of the disposer's disposal to the acquirer.

*Note—*

See part 10, division 3A, subdivision 3 for requirements about the notice.

- (7) An application under subsection (6)(a) must be accompanied by the following, to the extent they are applicable—
- (a) a gas certificate for each gas system in the vehicle;



- (b) if the purchase or other acquisition of the registered vehicle is a disposal for which, under the Vehicle Standards and Safety Regulation, a current inspection certificate is required—prescribed evidence of a current inspection certificate under that regulation for the vehicle.
- (8) The chief executive, on receipt of an application under subsection (1) or (6)(a), or a notice under subsection (3), or on being satisfied of the correctness of the information contained in a statement received under subsection (5), may—
  - (a) record in the register the day of the transfer given in or with the application, notice or statement; and
  - (b) substitute the name and address of the person acquiring the vehicle for those of the registered operator recorded in the register; and
  - (c) amend the register to record the postal address, or lack of a postal address, for the person acquiring the vehicle; and
  - (d) issue an updated registration certificate to the person acquiring the vehicle.
- (9) On receipt of a disposal notice under subsection (6)(b), the chief executive may—
  - (a) record in the register the day of disposal stated in the notice; and
  - (b) substitute the name and address of the acquirer for those of the registered operator recorded in the register; and
  - (c) amend the register to record the postal address, or lack of a postal address, for the acquirer.
- (9A) On receipt of a disposal notice under subsection (6)(b) or otherwise forming a reasonable belief that the acquirer has not applied for transfer of the vehicle’s registration under subsection (1), the chief executive may, by written notice to the acquirer, require the acquirer to apply for transfer of the vehicle’s registration within 14 days after the notice is given.

[s 49]

---

- (10) The acquirer must not contravene the requirement mentioned in subsection (9A) unless the acquirer has a reasonable excuse.

Maximum penalty—16 penalty units.

- (11) If the chief executive acts under subsection (9), the person in whose name the vehicle is registered or recorded in the register under a disposal notice is taken to be the vehicle's registered operator for this regulation until the chief executive receives another disposal notice for the vehicle or an application for transfer of the vehicle's registration.

#### **49 Failure by dealer to apply for transfer of registration**

- (1) This section applies if—
- (a) a person (the *buyer*) buys or otherwise acquires a registered vehicle from a dealer; and
  - (b) the dealer accepts from the buyer an amount mentioned in section 48(2)(a), (b) or (c).
- (2) The dealer must, within 14 days after the buyer's acquisition of the vehicle, apply to the chief executive on the buyer's behalf for transfer of the vehicle's registration.

Maximum penalty—16 penalty units.

*Note—*

See part 10, division 3A, subdivision 2 for requirements about the application.

- (3) The buyer does not contravene section 48(1) if an application is not made to the chief executive for transfer of the vehicle's registration within 14 days after the buyer's acquisition of the vehicle.

#### **50 Transfer of registration under legal process**

- (1) A person who obtains a registered vehicle under a legal process must give the chief executive notice of that fact within 14 days after obtaining the vehicle.

---

Maximum penalty—16 penalty units.

*Note—*

See part 10, division 3A, subdivision 3 for requirements about the notice.

- (2) A person who repossesses a registered vehicle that is not redeemed within 28 days after the repossession must, within a further 7 days, give the chief executive notice of the repossession and details of the proposed registered operator.

Maximum penalty—16 penalty units.

*Note—*

See part 10, division 3A, subdivision 3 for requirements about the notice.

- (3) A person mentioned in subsection (1) or (2) (the *new owner*) who is unable to include the signature of the vehicle's registered operator in the notice, must give a statement to that effect to the chief executive.

*Note—*

See part 10, division 3A, subdivision 3 for requirements about the statement.

- (4) Subsection (5) applies if the chief executive is satisfied—
- (a) the information contained in a statement received under subsection (3) is correct; and
  - (b) the new owner has a lawful entitlement to the vehicle.
- (5) The chief executive may—
- (a) record the day of the transfer stated in the notice in the register; and
  - (b) substitute the new owner's name and address for those of the registered operator recorded in the register; and
  - (c) amend the register to record the postal address, or lack of a postal address, for the new owner; and
  - (d) give the new registered operator an updated registration certificate.

[s 51]

---

- (6) A notice under subsection (1) or (2) must be accompanied by the amounts, and by the documents, that would be required under section 48(2) were the notice an application for a transfer of the vehicle's registration.

## **51 Refusing to record transfer of registration**

- (1) The chief executive may refuse to record a transfer of a vehicle's registration if—
  - (a) the vehicle is a conditionally registered vehicle and a condition in the safe movement guideline or heavy vehicle standards exemption is that the registration is not transferable; or
  - (b) the chief executive reasonably believes there is uncertainty about the ownership, possession or control of the vehicle or that the description of the vehicle as recorded in the register may be inaccurate; or
  - (c) were the vehicle to be the subject of an application for registration, the chief executive would refuse the application.
- (2) If an order of an Australian court prohibits the transfer of a vehicle's registration and the chief executive has notice of the order, the chief executive must not record a transfer of the registration.
- (3) Subsections (1) and (2) do not limit the chief executive's power to refuse to record the transfer of a vehicle's registration.

*Note—*

See section 19M of the Act, which prohibits recording the transfer of registration in particular circumstances.

---

## Part 6                      Expiry and cancellation of registration

### Division 1                Expiry of registration

#### 52            Expiry of registration

A vehicle's registration expires at the end of the day recorded in the register as the expiry day of the registration unless the registration is sooner cancelled or renewed under this regulation.

#### 53            Return of registration plates when registration expires

- (1) The chief executive may by written notice given to the person who was the registered operator of a vehicle whose registration has expired, require the person to return the vehicle's number plates to the chief executive within 14 days of the date of the notice (the *return period*).
- (2) The person must, within the return period—
  - (a) return the vehicle's number plates to the chief executive; or
  - (b) if the plates have been lost, stolen or destroyed, give the chief executive notice of the details of the loss, theft or destruction.

*Note—*

See part 10, division 3A, subdivision 3 for requirements about the notice.

Maximum penalty—20 penalty units.

## **Division 2                      Cancellation of registration**

### **54            Cancellation of registration at registered operator's request**

- (1) The registered operator of a vehicle may apply to the chief executive to cancel the vehicle's registration if—
  - (a) the registered operator of the vehicle is a dealer, and the vehicle is for sale; or
  - (b) the vehicle—
    - (i) has been stolen; or
    - (ii) has been taken out of Queensland; or
    - (iii) has stopped being used on roads; or
    - (iv) is a total loss.

*Note—*

See part 10, division 3A, subdivision 2 for requirements about the application.

- (2) If cancellation is applied for under subsection (1)(b)(iv), the application must include a statement by or for the applicant that the vehicle has not been used on a road since it became a total loss.
- (3) Also, a person acting under the authority of a court to sell a vehicle may apply to the chief executive to cancel the vehicle's registration.

*Note—*

See part 10, division 3A, subdivision 2 for requirements about the application.

- (4) If the application of the registered operator of a vehicle to cancel the vehicle's registration is made by another person on behalf of the registered operator, the other person must give the chief executive written evidence of the other person's appointment, as the registered operator's agent, with the application.

- (5) If a person acting under the authority of a court to sell a vehicle applies to the chief executive to cancel the vehicle's registration, the person must give the chief executive, with the application, written evidence of the person's authority to sell the vehicle.
- (6) A person applying under subsection (1) or (3) must include with the application—
  - (a) if a number plate for the vehicle has been lost, stolen or destroyed—
    - (i) a statement advising of the loss, theft or destruction; and
    - (ii) any number plate for the vehicle, other than a special plate, that is not lost, stolen or destroyed; or
  - (b) otherwise—the number plates, other than special plates, for the vehicle.
- (7) Also, if the vehicle is a total loss, the person must include with the application the notifiable information for the vehicle the person would have been required to give the chief executive under section 75.
- (8) The chief executive must cancel the vehicle's registration unless—
  - (a) the applicant has not complied with subsection (4), (5), (6) or (7); or
  - (b) the chief executive is already taking action to cancel the registration because of a ground mentioned in section 57 or 58.
- (9) Subsection (6) does not apply to a registered operator of a category 2 vehicle if—
  - (a) the number plate for the vehicle is a national heavy vehicle number plate; and
  - (b) the registered operator has registered the vehicle in another State under a corresponding law to this regulation.

## **55 Cancellation if registration in other State**

The chief executive may cancel a vehicle's registration other than on a person's application if the chief executive knows that the vehicle has been registered in another State under a corresponding law to this regulation.

## **55A Cancellation of registration at request of chief executive officer of a local government**

- (1) The chief executive officer of a local government may apply to the chief executive to cancel a vehicle's registration if—
  - (a) under section 100(6) of the Act a person has not obtained possession of the vehicle; or
  - (b) under a local law the local government may dispose of the vehicle.
- (2) An application made under subsection (1) must include—
  - (a) a statement that the chief executive officer of the local government has complied with—
    - (i) section 100 (4), (5), and (6)(a) of the Act; or
    - (ii) a local law that provides for the disposal of the vehicle; and
  - (b) if attached to the vehicle—the number plates, other than special plates, for the vehicle.

*Note—*

See part 10, division 3A, subdivision 2 for requirements about the application.

- (3) The chief executive must cancel the vehicle's registration unless—
  - (a) the chief executive officer of the local government has not complied with subsection (2); or
  - (b) the chief executive is already taking action to cancel the registration because of a ground mentioned in section 57 or 58.



---

**55B Cancellation of registration at request of the commissioner**

- (1) The commissioner may apply to the chief executive to cancel a vehicle's registration if the vehicle—
  - (a) becomes the property of the State under the *Police Powers and Responsibilities Act 2000*, section 74B(2), 74F(2) or 101(6); or
  - (b) is, or is taken to have been, forfeited to the State under the *Police Powers and Responsibilities Act 2000*, section 118(3), 118A(3) or 766(4)(a).
- (2) An application made under subsection (1) must include—
  - (a) a statement that the vehicle has become the property of, or been forfeited to, the State under the *Police Powers and Responsibilities Act 2000*; and
  - (b) if attached to the vehicle—the number plates, other than special plates, for the vehicle.

*Note—*  
See part 10, division 3A, subdivision 2 for requirements about the application.
- (3) The chief executive must cancel the vehicle's registration unless—
  - (a) the commissioner has not complied with subsection (2); or
  - (b) the chief executive is already taking action to cancel the registration because of a ground mentioned in section 57 or 58.

**56 Partial refund of registration fee**

- (1) This section applies if a vehicle's registration is cancelled under any of sections 54 to 55B.
- (2) The chief executive must make a partial refund of the registration fee paid for the vehicle to the person who was the registered operator immediately before the cancellation.

[s 57]

---

- (3) The refund is worked out using the following formula—

$$\text{refund} = \frac{\text{number of days}}{365} \times \text{annual registration fee}$$

where—

*number of days* is the number of unexpired whole days of the registration term for which the fee was paid, from the day on which the chief executive approves the application to cancel the registration.

- (4) However, the chief executive may deduct from the refund—
- (a) the administration fee for making the refund stated in schedule 3; and
  - (b) any unpaid fees payable under a transport Act for the vehicle.

## **57 Cancellation for noncompliance with notice about defective or unsafe vehicle**

- (1) Grounds on which the registration of a registered vehicle may be cancelled are stated in schedule 7.
- (2) If the chief executive decides to cancel the registration of a registered vehicle under section 19(2)(c) of the Act on a ground stated in schedule 7, the chief executive must include in the written notice given under section 19(3) of the Act a requirement that the person (the *relevant person*) to whom the notice is directed must return the number plates for the vehicle to the chief executive within 14 days after the giving of the notice (the *return period*).
- (3) The relevant person must comply with the requirement under subsection (2) within the return period.

Maximum penalty—20 penalty units.

- (4) However, if a number plate has been lost, stolen or destroyed, the relevant person does not contravene subsection (3) if the relevant person, within the return period, gives the chief executive notice of the details of the loss, theft or destruction.

*Note—*

See part 10, division 3A, subdivision 3 for requirements about the notice.

## 58 Cancellation of registration of vehicle or dealer plate

- (1) This section applies if—
  - (a) a registered vehicle does not conform with the requirements applying to the vehicle under a vehicle law about the construction, equipment and performance of motor vehicles; or
  - (b) the acquirer of a vehicle does not comply with a notice given under section 48(9A); or
  - (c) the registration or renewal of registration of a vehicle or dealer plate is paid for by a cheque, or by another method of payment, that is not honoured on presentation or is later dishonoured, and the chief executive has not yet received full payment for the registration or renewal; or
  - (d) less than the correct amount is paid in relation to the payment for registration, or renewal of registration, of a vehicle or dealer plate, and the chief executive has not yet received the unpaid amount; or
  - (e) a vehicle is recorded in the register as a written-off vehicle; or
  - (f) the application for the registration of a vehicle or dealer plate was not accompanied by a document required under section 13(1) in relation to a vehicle or section 62(4) in relation to a dealer plate.
- (2) If this section applies in relation to a vehicle, a ground exists to cancel the registration of the vehicle.
- (3) If the chief executive decides to cancel the vehicle's registration under section 19(2)(c) of the Act, the chief executive must include in the written notice given under section 19(3) of the Act a requirement that the person (the *relevant person*) to whom the notice is directed must return

[s 58]

---

the number plates for the vehicle to the chief executive within 14 days after the giving of the notice (the *return period*).

- (4) The relevant person must comply with the requirement under subsection (3) within the return period.

Maximum penalty—20 penalty units.

- (5) However, if a number plate has been lost, stolen or destroyed, the relevant person does not contravene subsection (4) if the relevant person, within the return period, gives the chief executive notice of the details of the loss, theft or destruction.

*Note—*

See part 10, division 3A, subdivision 3 for requirements about the notice.

- (6) If this section applies in relation to a dealer plate, a ground exists to cancel the registration of the dealer plate.

- (7) If the chief executive decides to cancel the registration of the dealer plate under section 19(2)(c) of the Act, the chief executive must include in the written notice given under section 19(3) of the Act a requirement that the person (the *dealer plate holder*) to whom the notice is directed must return the dealer plate to the chief executive within 14 days after the giving of the notice (the *dealer plate return period*).

- (8) The dealer plate holder must comply with the requirement under subsection (7) within the dealer plate return period.

Maximum penalty—30 penalty units.

- (9) However, if the dealer plate has been lost, stolen or destroyed, the dealer plate holder does not contravene subsection (8) if the dealer plate holder, within the dealer plate return period, gives the chief executive notice of the details of the loss, theft or destruction.

*Note—*

See part 10, division 3A, subdivision 3 for requirements about the notice.

- (10) Nothing in this section stops the chief executive from recovering from the relevant person or dealer plate holder an amount, worked out on a proportional basis, of any amount

---

for registration referable to the period ending on the cancellation.

- (10A) For the purpose of recovering from the relevant person or dealer plate holder the amount mentioned in subsection (10), the chief executive may, by written notice, require the relevant person or dealer plate holder to pay the amount.
- (10B) A relevant person to whom a notice is given under subsection (10A) must pay the amount within 28 days after the chief executive gives the notice.

Maximum penalty—

- (a) if the amount is in relation to a category 1 vehicle—20 penalty units; or
- (b) if the amount is in relation to a category 2 vehicle—60 penalty units.
- (10C) A dealer plate holder to whom a notice is given under subsection (10A) must pay the amount within 28 days after the chief executive gives the notice.

Maximum penalty—30 penalty units.

- (11) Section 56 of the Act does not apply to a registration, or renewal of registration, of a vehicle or dealer plate.

## **59 Recording cancellation of registration in register**

- (1) If the chief executive cancels a vehicle's registration, the chief executive must record the cancellation in the register.
- (2) If the vehicle's registered operator applied for the cancellation under section 54(1)(a) or (b)(ii) or (iii), the cancellation is effective on the day of receipt of the application conforming with that section.
- (3) However, if on an application under subsection 54(1)(b)(ii) the chief executive is satisfied the vehicle has been registered in another State under a corresponding law to this regulation, the cancellation is taken to be effective on the day immediately after the day the vehicle was registered in the other State.

[s 59A]

---

- (4) If the vehicle's registered operator applied for the cancellation under section 54(1)(b)(i), the cancellation is effective on the day after the vehicle is reported as stolen to the Queensland Police Service.
- (5) If the vehicle's registered operator applied for the cancellation under section 54(1)(b)(iv), the cancellation is effective on the day after the day the vehicle stopped being used on roads as a result of it having become a total loss.
- (6) If the chief executive cancels a vehicle's registration under section 55, the cancellation is taken to be effective on the day immediately after the day the vehicle was registered in the other State.
- (7) If none of subsections (2) to (6) apply, the cancellation is effective on the day the chief executive records the cancellation in the register.

### **59A Cancellation of heavy vehicle registration by court**

- (1) This section applies if a court makes an order under the Heavy Vehicle National Law (Queensland), section 598(2) that the registration of a heavy vehicle is cancelled.
- (2) The chief executive must—
  - (a) record the cancellation in the register; and
  - (b) give a written notice to the person who, immediately before the cancellation took effect, was the registered operator of the heavy vehicle—
    - (i) advising the person that the cancellation has been recorded; and
    - (ii) requiring the person to return the vehicle's number plates to the chief executive within 14 days after the giving of the notice.
- (3) A person given a written notice under subsection (2)(b) must comply with the requirement mentioned in subsection (2)(b)(ii) unless the person has a reasonable excuse.

---

Maximum penalty—20 penalty units.

## **Part 7                      When registration unnecessary**

### **Division 1                      Unregistered vehicle permits**

#### **60                      Unregistered vehicle permits**

- (1) A person may apply to the chief executive to authorise the use of an unregistered vehicle on a road by issuing an unregistered vehicle permit for the vehicle.

*Note—*

See part 10, division 3A, subdivision 2 for requirements about the application.

- (2) The application must be accompanied by—
- (a) the relevant fee; and
  - (b) any insurance certificate required under the *Motor Accident Insurance Act 1994* for the vehicle for the proposed term of the permit or the insurance premium payable under that Act for the certificate.
- (3) The chief executive may issue the permit for the term, which must not be longer than 7 days, and on the reasonable conditions, stated in it.
- (4) If the permit is issued on conditions, it is void if the conditions are contravened.
- (5) A person to whom an unregistered vehicle permit is issued must ensure that, whenever the vehicle is being used under the permit on a road—
- (a) if the vehicle is a trailer—the driver of the vehicle towing the trailer carries the permit in that vehicle; or
  - (b) otherwise—the driver of the vehicle carries the permit.

Maximum penalty—12 penalty units.

[s 61]

---

- (6) The chief executive may not issue an unregistered vehicle permit for a vehicle that—
  - (a) does not conform with the requirements applying to the vehicle under a vehicle law; or
  - (b) is recorded in the register, or in a register kept under a corresponding law to this regulation, as a written-off vehicle.

## **Division 2            Dealer plates**

### **61            Designation of dealer plates**

The chief executive may designate a series of number plates as dealer plates.

### **62            Registration of dealer plate**

- (1) An unregistered vehicle may be used on a road if—
  - (a) a dealer plate is attached to the vehicle; and
  - (b) the registration of the dealer plate is current.
- (2) The chief executive must not register a dealer plate unless the chief executive is satisfied that the person in whose name the dealer plate is to be registered is a person who requires the plate for the conduct of the person's business.
- (3) A person may apply to the chief executive for registration of a dealer plate.

*Note—*

See part 10, division 3A, subdivision 2 for requirements about the application.

- (4) The application must be accompanied by—
  - (a) the relevant fee; and
  - (b) any insurance certificate required under the *Motor Accident Insurance Act 1994* for the proposed



---

registration term or the insurance premium payable under that Act for the certificate.

- (5) On registering the dealer plate, the chief executive must—
- (a) assign a registration number to the person to whom the dealer plate is issued; and
  - (b) record in the register the following particulars—
    - (i) the name, address and place of business of the person to whom the plate has been issued;
    - (ii) if there is a current postal address for the person to whom the plate has been issued—the postal address;
    - (iii) commencement and expiry days for the registration of the dealer plate; and
  - (c) give the applicant—
    - (i) a registration certificate; and
    - (ii) the dealer plate.
- (6) The registration of a dealer plate is renewable, but is not transferable.
- (7) In this section—
- unregistered vehicle*** does not include a vehicle that—
- (a) is not capable of being registered under this regulation; or
  - (b) is only capable of being conditionally registered with limited access registration or zone access registration.

## 63 Attaching dealer plate

- (1) The person in whose name a dealer plate is registered must ensure that, when an unregistered vehicle is used under the authority of the dealer plate on a road, the dealer plate is attached to the vehicle in the way required under subsection (2).

Maximum penalty—12 penalty units.

[s 64]

---

- (2) The plate must be attached to the vehicle in the way required if the dealer plate were a number plate issued for the vehicle.
- (3) However, the dealer plate need not be permanently attached to the vehicle but must be attached to the vehicle in a manner that prevents substantial movement of the dealer plate.

## **64 Use of dealer plates**

- (1) A person must not use, or permit to be used, on a road a vehicle with a dealer plate attached to it unless the vehicle—
  - (a) is being demonstrated for its sale; or
  - (b) is being delivered to a purchaser after sale; or
  - (c) is travelling to or from a workshop or another facility for—
    - (i) painting, repairs or motor body construction work; or
    - (ii) the fitting of optional equipment before delivery to a purchaser; or
  - (d) is being tested after having been painted or repaired, or after having been the subject of motor body construction work; or
  - (e) is being used for demonstration purposes for the conduct of an art union under the *Charitable and Non-Profit Gaming Act 1999*; or
  - (f) is being used for a purpose approved by the chief executive in a written notice given to the person in whose name the dealer plate is registered; or
  - (g) is being driven or towed for testing to confirm the safe operation of the vehicle as part of an inspection for obtaining an inspection certificate under the Vehicle Standards and Safety Regulation; or
  - (h) is being driven or towed to an AIS for inspection for obtaining an inspection certificate under the Vehicle Standards and Safety Regulation; or

- 
- (i) is recorded in the register as a repairable write-off and is being driven or towed to a written-off vehicle inspection site for obtaining a written-off vehicle inspection report; or
  - (j) is being driven or towed to a place as required by the chief executive; or
  - (k) is being driven or towed to an office of the chief executive to be registered; or
  - (l) is being driven or towed from the manufacturer or a distributor of the vehicle to a dealer; or
  - (m) is being driven or towed between a dealer's premises and other premises of the same or a different dealer, whether or not a sale has taken place.

Maximum penalty—16 penalty units.

- (1A) Section 15, and not this section, applies in relation to a vehicle if—
  - (a) a person uses, or permits to be used on a road the vehicle with a dealer plate attached to it and the vehicle is being driven or towed, as mentioned in subsection (1)(g), (h), (i), (j) or (k); and
  - (b) the requirements of section 15(1) are complied with for the vehicle.
- (2) A person must not use, or permit to be used, on a road a vehicle with a dealer plate, other than a dealer (trailer trade) plate, attached to it if the vehicle is carrying a load or towing a vehicle carrying a load, unless the vehicle with the dealer plate attached—
  - (a) is a boat trailer carrying a boat; or
  - (b) is towing a motor vehicle travelling on its rear wheels only, with its front part mounted on the towing vehicle; or
  - (c) is carrying the load only to demonstrate the vehicle for its sale, and not for hire or reward.

Maximum penalty—40 penalty units.

[s 65]

---

- (3) A person must not use, or permit to be used, on a road a vehicle with a dealer (trailer trade) plate attached to it unless the vehicle is—
- (a) a trailer not carrying a load; or
  - (b) a boat trailer, carrying 1 or more boat trailers, being towed from the manufacturer or a distributor of all the trailers to a dealer; or
  - (c) a boat trailer carrying a boat; or
  - (d) a trailer carrying a load only to demonstrate the trailer for its sale, and not for hire or reward.

Maximum penalty—40 penalty units.

- (4) A person must not use, or permit to be used, on a road a vehicle with a dealer plate attached to it unless the person in whose name the dealer plate is registered—
- (a) is the person who used the dealer plate; or
  - (b) authorised the person to use, or permit another person to use, the dealer plate.

Maximum penalty—16 penalty units.

- (5) A person must not use, or permit to be used, on a road a vehicle with a dealer plate attached to it unless the vehicle is used in the conduct of the business of the person in whose name the dealer plate is registered.

Maximum penalty—16 penalty units.

- (6) In this section—

*dealer (trailer trade) plate* means a dealer plate issued under this division authorising the use of an unregistered trailer on a road.

## 65 Cancellation of dealer plates

- (1) The chief executive may cancel the registration of a dealer plate, and record the cancellation in the register, if the person in whose name the plate is registered—

- (a) applies to the chief executive for the cancellation; and

*Note—*

See part 10, division 3A, subdivision 2 for requirements about the application.

- (b) unless the person has given the chief executive notice of the details of the loss, theft or destruction of the dealer plate—returns the dealer plate to the chief executive.

*Note—*

See part 10, division 3A, subdivision 3 for requirements about the notice.

- (2) Subsection (3) applies if either of the following events (the **relevant event**) happens in relation to a person in whose name a dealer plate is registered—

- (a) the person stops carrying on the business for which the plate was registered;
- (b) there is a material change in the nature of the person's business from that stated in the person's application for the registration of the plate.

- (3) The person must, within 14 days after the relevant event happens—

- (a) give the chief executive notice about the relevant event; and

*Note—*

See part 10, division 3A, subdivision 3 for requirements about the notice.

- (b) return the dealer plate to the chief executive.

Maximum penalty—30 penalty units.

- (4) On receiving a notice under subsection (3), the chief executive must cancel the registration of the dealer plate and record in the register the cancellation of the registration.
- (5) A ground exists to cancel the registration of a dealer plate if a person required to comply with subsection (3) does not notify the chief executive under subsection (3)(a).

[s 65]

---

- (6) If, the chief executive decides to cancel the registration of a dealer plate under section 19(2)(c) of the Act, the chief executive must include in the written notice given under section 19(3) of the Act a requirement that the person (the **relevant person**) to whom the notice is directed must, unless the relevant person has already done so, return the dealer plate to the chief executive within 14 days after the giving of the notice.
- (7) The relevant person must comply with the requirement under subsection (6).

Maximum penalty—30 penalty units.

- (8) If a dealer plate required to be returned under subsection (3)(b) or (7) (the **relevant provision**) has been lost, stolen or destroyed, the person required to return the dealer plate does not contravene the relevant provision if the person, in the period within which the dealer plate is required to be returned, gives the chief executive notice of the details of the loss, theft or destruction.

*Note—*

See part 10, division 3A, subdivision 3 for requirements about the notice.

- (9) The cancellation of the registration of a dealer plate is effective—
- (a) for a cancellation under subsection (1)—immediately the person has complied with the subsection; or
- (b) otherwise—on the day the chief executive records the cancellation in the register.

---

## **Part 8**                      **Written-off vehicles**

### **Division 1**                **Objects of part 8**

#### **66**      **Objects**

The objects of this part include—

- (a) to provide for the collection of information about written-off vehicles; and
- (b) to provide for the inspection of written-off vehicles that are repairable write-offs.

### **Division 1A**            **Classification of written-off vehicles**

#### **66A**    **Written-off vehicle to be classified as statutory write-off or repairable write-off**

- (1) This section applies to—
    - (a) a notifier required under this regulation to give notifiable information for a written-off vehicle to the chief executive; or
    - (b) a person assisting a notifier mentioned in paragraph (a) to determine if a vehicle is a written-off vehicle for which the notifier is required to give notifiable information to the chief executive.
  - (2) If the notifier or person assesses a notifiable vehicle as a total loss the notifier or person must—
    - (a) if the vehicle is a total loss because of corrosion or because of damage that satisfies the statutory write-off assessment criteria for the vehicle—classify the vehicle as a statutory write-off; or
    - (b) otherwise—classify the vehicle as a repairable write-off.
- Maximum penalty—50 penalty units.

## **Division 2                      Notifying of written-off vehicle information**

### **67            General obligations of notifiers**

- (1) The chief executive may require a notifier required to give notifiable information for a written-off vehicle under this regulation to give to the chief executive information, other than notifiable information, for the vehicle.
- (2) The information the chief executive may require under subsection (1) must be information the chief executive reasonably considers is required to maintain the integrity of information about written-off vehicles kept by the chief executive in the register.
- (3) The notifier must comply with a requirement given under this section.

Maximum penalty for subsection (3)—20 penalty units.

### **68            Auditing of notifiers**

- (1) The chief executive must conduct audits of notifiers' operations as givers of notifiable information about written-off vehicles under this regulation.
- (2) A notifier must allow the notifier's operations as a giver of notifiable information to be audited by the chief executive.

Maximum penalty—20 penalty units.

- (3) If the report of an audit under this section identifies noncompliance with this regulation, the chief executive may, by written notice given to the notifier, require the notifier to give the chief executive, within 14 days after the date of the notice, a notice (a *rectification notice*) stating the action the notifier has taken to do either or both of the following, as directed in the chief executive's notice—
  - (a) rectify the noncompliance;



- (b) ensure that the noncompliance does not continue or happen again.

*Note—*

See part 10, division 3A, subdivision 3 for requirements about the rectification notice.

- (4) The notifier must comply with the requirement, unless the notifier has a reasonable excuse.

Maximum penalty—20 penalty units.

- (5) In a proceeding against the notifier for an offence against this regulation, other than for an offence against subsection (4), neither the rectification notice, nor the fact that the notifier gave the rectification notice, can be used in evidence against the notifier.
- (6) If an audit report identifies material noncompliance with this regulation, the notifier must pay the cost of the audit and of compiling the audit report, but is not otherwise required to pay the cost.

## **68A Chief executive to advise notifier of label specifications**

The chief executive must advise a notifier of the chief executive's specifications for a label of the kind a notifier is required, under section 77, to attach to a written-off vehicle.

*Editor's note—*

The department advises notifiers of label specifications when notifiers register themselves with the department. The label specifications are also available from the department on request.

## **69 Obligation of notifiers to give notifiable information**

- (1) A notifier must, under this division, give notifiable information for a vehicle to the chief executive.

*Note—*

See part 10, division 3A, subdivision 3 for requirements about the giving of the notifiable information.

[s 70]

---

- (2) A notifier may change details of the notifiable information given to the chief executive for a vehicle by giving notice of the change to the chief executive, but only if—
  - (a) the vehicle has not been repaired; and
  - (b) the vehicle has not left the notifier's possession since the notifier gave the information to the chief executive.

*Note—*

See part 10, division 3A, subdivision 3 for requirements about the notice.

- (3) Also, a notifier may at any time apply to the chief executive for approval to correct a clerical or technical error in notifiable information the notifier has given to the chief executive for a vehicle.

*Note—*

See part 10, division 3A, subdivision 2 for requirements about the application.

- (4) A notifier must not knowingly or recklessly give notifiable information for a vehicle to the chief executive that is false or misleading in a material particular.

Maximum penalty for subsection (5)—80 penalty units.

## **70 Obligation of insurer to report written-off vehicle**

- (1) This section applies if an insurer, in the course of the business carried on by the insurer in Queensland, and whether or not on the advice of a loss adjuster—
  - (a) assesses as a total loss a notifiable vehicle registered under this regulation; or
  - (b) assesses as a total loss a notifiable vehicle that is anywhere in Australia, but is not registered under this regulation or a corresponding law to this regulation.
- (2) The insurer must give the chief executive the notifiable information for the vehicle before the first of the following happens—

- 
- (a) 7 days elapse after the insurer makes a final decision for a claim in relation to the vehicle;
  - (b) the insurer—
    - (i) disposes of the vehicle; or
    - (ii) disposes of any part of the vehicle that has a chassis number or VIN; or
    - (iii) sells the vehicle; or
    - (iv) sells any part of the vehicle that has a chassis number or VIN.

Maximum penalty—50 penalty units.

## **71 Obligation of self-insurer to report written-off vehicle**

- (1) This section applies if a self-insurer—
  - (a) assesses as a total loss a notifiable vehicle registered under this regulation in the name of the self-insurer; or
  - (b) assesses as a total loss a notifiable vehicle that is anywhere in Australia and is owned by the self-insurer, but is not registered under this regulation or a corresponding law to this regulation.
- (2) The self-insurer must give the chief executive the notifiable information for the vehicle before the first of the following happens—
  - (a) 7 days elapse after making the assessment;
  - (b) the self-insurer—
    - (i) disposes of the vehicle; or
    - (ii) disposes of any part of the vehicle that has a chassis number or VIN; or
    - (iii) sells the vehicle; or
    - (iv) sells any part of the vehicle that has a chassis number or VIN.

Maximum penalty—50 penalty units.

[s 72]

---

## **72 Obligation of loss adjuster to report written-off vehicle**

- (1) This section applies if a loss adjuster, acting in the course of the business carried on by the loss adjuster, but acting other than to advise an insurer, auctioneer or dealer—
  - (a) assesses as a total loss a notifiable vehicle registered under this regulation; or
  - (b) assesses as a total loss a notifiable vehicle that is in Queensland, but is not registered under this regulation or a corresponding law to this regulation.
- (2) The loss adjuster must give the chief executive the notifiable information for the vehicle within 7 days after finalising the loss adjuster's assessment of the vehicle.

Maximum penalty—50 penalty units.

## **73 Obligation of dealer or auctioneer to report written-off vehicle**

- (1) This section applies if a person who is a dealer or an auctioneer, in the course of the business carried on by the person, has in the person's possession—
  - (a) a notifiable vehicle, registered under this regulation, that is a total loss; or
  - (b) a notifiable vehicle, not registered under this regulation or a corresponding law to this regulation, that is a total loss.
- (2) The person must give the chief executive the notifiable information for the vehicle before the first of the following happens—
  - (a) 7 days elapse after the person takes possession of the vehicle;
  - (b) the auctioneer or dealer—
    - (i) disposes of the vehicle; or
    - (ii) disposes of any part of the vehicle that has a chassis number or VIN; or

- (iii) sells the vehicle; or
- (iv) sells any part of the vehicle that has a chassis number or VIN.

Maximum penalty—50 penalty units.

- (3) The person is not required to act under subsection (2) if the person is able to show that—
  - (a) the person searched the register or arranged for the register to be searched; and
  - (b) the search result showed that someone else had already given the notifiable information for the vehicle to the chief executive.
- (4) In this section—

*possession* includes custody or control.

#### **74 Obligation of auto parts dismantler to report written-off vehicle**

- (1) This section applies if a person who is an auto parts dismantler, in the course of the business carried on by the person—
  - (a) assesses as a total loss a notifiable vehicle registered under this regulation; or
  - (b) assesses as a total loss a notifiable vehicle that is in Queensland, but is not registered under this regulation or a corresponding law to this regulation.
- (2) The person must give the chief executive the notifiable information for the vehicle before the first of the following happens—
  - (a) 7 days elapse after the person takes possession of the vehicle;
  - (b) the person—
    - (i) demolishes or dismantles the vehicle; or
    - (ii) disposes of the vehicle; or

[s 75]

---

- (iii) disposes of any part of the vehicle that has a chassis number or VIN; or
- (iv) sells the vehicle; or
- (v) sells any part of the vehicle that has a chassis number or VIN.

Maximum penalty—50 penalty units.

- (3) The person is not required to act under subsection (2) if someone else has already given the notifiable information for the vehicle to the chief executive.
- (4) Despite subsection (3), the person must give the chief executive the notifiable information for the vehicle on demolishing or dismantling the vehicle.

## **75 Obligation of registered operator or owner of unregistered vehicle to report written-off vehicle**

- (1) This section applies if a person, other than a self-insurer, proposes to sell or otherwise dispose of a notifiable vehicle, or a part of a notifiable vehicle that has an identifying number, and—
  - (a) the vehicle is a total loss; and
  - (b) either—
    - (i) the person is the registered operator of the vehicle; or
    - (ii) if the vehicle is not registered under this regulation or a corresponding law to this regulation, the person is the owner of the vehicle and the vehicle is in Queensland.
- (2) The person must give the chief executive notice of the notifiable information for the vehicle before—
  - (a) disposing of the vehicle; or
  - (b) disposing of any part of the vehicle that has a chassis number or VIN; or
  - (c) selling the vehicle; or

- 
- (d) selling any part of the vehicle that has a chassis number or VIN.

Maximum penalty—10 penalty units.

*Note—*

See part 10, division 3A, subdivision 3 for requirements about the notice.

- (3) Despite subsection (2), the person is not required to state whether the vehicle is a repairable write-off or a statutory write-off.
- (4) The chief executive is taken to have been notified that the vehicle is a repairable write-off unless someone else has already—
- (a) given the notifiable information for the vehicle to the chief executive; and
- (b) stated that the vehicle is a statutory write-off.
- (5) The person is not required to act under subsection (2) if someone else has already given the information to the chief executive.

**75A Chief executive to give label for written-off vehicle to registered operator or owner of unregistered vehicle**

- (1) This section applies if, under section 75(2), a person gives the chief executive notifiable information for a vehicle.
- (2) On receiving the information, the chief executive must give the person a label for the vehicle that states—
- (a) the vehicle is a written-off vehicle; and
- (b) any other information the chief executive considers appropriate.

*Notes—*

- 1 See section 68A for the requirements of a label given under subsection (2).
- 2 See section 78 for the obligation of the registered operator, or the owner, of the vehicle to attach the label to the vehicle.

[s 76]

---

**76 Notifier’s obligation to inform registered operator or owner of unregistered vehicle**

- (1) This section applies if—
  - (a) a notifier gives the notifiable information for a notifiable vehicle to the chief executive under this part; and
  - (b) the notifier is not the owner of the vehicle.
- (2) Within 7 days after the notifier gives the notifiable information for the vehicle to the chief executive, the notifier must inform, in writing, the registered operator or, if the vehicle is not registered under this regulation or a corresponding law to this regulation, the owner of the vehicle that—
  - (a) the notifier has given the notifiable information for the vehicle to the chief executive; and
  - (b) the vehicle is—
    - (i) if the vehicle is a repairable write-off—a repairable write-off and can be registered under this regulation only if it passes a written-off vehicle inspection; or
    - (ii) if the vehicle is a statutory write-off—a statutory write-off and can not be registered under this regulation.

Maximum penalty—10 penalty units.

**77 Notifier’s obligation to attach label to written-off vehicle**

- (1) This section applies if a notifier gives notifiable information for a notifiable vehicle to the chief executive.
- (2) On giving the information to the chief executive, the notifier must, under subsection (3), attach to the vehicle a label that—
  - (a) meets the chief executive’s specifications mentioned in section 68A; and
  - (b) states that the vehicle is—



- (i) if the vehicle is a repairable write-off—a repairable write-off and can be registered under this regulation only if it passes a written-off vehicle inspection; or
- (ii) if the vehicle is a statutory write-off—a statutory write-off and can not be registered under this regulation.

Maximum penalty—30 penalty units.

- (3) The notifier must attach the label to the vehicle in a conspicuous position so as to be clearly visible from outside the vehicle.

*Examples of when a label is not attached in a conspicuous position—*

- label attached to back seat
- label attached to vehicle floor

- (4) However, if it is not reasonably practicable for the notifier to attach the label to the vehicle the notifier must, within 7 days after giving the notifiable information for the vehicle to the chief executive, give the registered operator or, if the vehicle is not registered under this regulation or a corresponding law to this regulation, the owner of the vehicle—
  - (a) a label for the vehicle that complies with subsection (2)(a) and (b); and
  - (b) a notice, in the approved form, about the label.

*Example of when it is not reasonably practicable for a notifier to attach a label to a written-off vehicle—*

A notifiable vehicle is located in a remote area. The notifier has assessed the vehicle to be a written-off vehicle based on photographic evidence or on a report prepared by a loss adjuster who has assessed the vehicle at the remote location.

Maximum penalty—30 penalty units.

## **78 Obligation on registered operator or owner of unregistered vehicle to attach label to written-off vehicle**

- (1) This section applies if the registered operator of a notifiable vehicle or, if the vehicle is not registered under this regulation

[s 79]

---

or a corresponding law to this regulation, the owner of the notifiable vehicle receives a label for the vehicle from—

- (a) the chief executive under section 75A; or
  - (b) a notifier under section 77(4).
- (2) Within 24 hours after receiving the label, the registered operator, or the owner, must attach the label to the vehicle in a conspicuous position so as to be clearly visible from outside the vehicle.

*Examples of when a label is not attached in a conspicuous position—*

- label attached to back seat
- label attached to vehicle floor

Maximum penalty—30 penalty units.

## **79 Offence to remove written-off vehicle label**

A person must not remove from a vehicle a label attached to the vehicle under this part while the vehicle is recorded in the register as a written-off vehicle, unless the person has a reasonable excuse.

Maximum penalty—30 penalty units.

## **80 Written-off vehicles must not be used on road**

- (1) A person must not use, or permit to be used, on a road a vehicle that is recorded in a relevant register as a statutory write-off.

Maximum penalty—20 penalty units.

- (2) A person must not use, or permit to be used, on a road a vehicle that is—
- (a) registered under this regulation or under a corresponding law to this regulation; and
  - (b) recorded in a relevant register as a repairable write-off.

Maximum penalty—20 penalty units.

- 
- (3) A person does not commit an offence against subsection (2) if—
- (a) the person drives or tows the vehicle to any of the places mentioned in subsection (4), or for the testing mentioned in subsection (5), if it is necessary for, or reasonably connected with, changing a relevant register to no longer record the vehicle as a repairable write-off; or
  - (b) the person is acting in accordance with an approval given by the chief executive for the vehicle.

*Note—*

The chief executive may issue the approval by phone, fax, radio or another form of communication.

- (4) For subsection (3)(a), the places are as follows—
- (a) an AIS, if the vehicle is driven or towed to the AIS for inspection for the purpose of obtaining an inspection certificate under the Vehicle Standards and Safety Regulation;
  - (b) a written-off vehicle inspection site, if there is a current inspection certificate for the vehicle under the Vehicle Standards and Safety Regulation and it is driven or towed to the site for the purpose of obtaining a written-off vehicle inspection report;
  - (c) the vehicle's garage address, if there is a current inspection certificate for the vehicle under the Vehicle Standards and Safety Regulation;
  - (d) another place, if the chief executive requires the vehicle to be taken to the place.

*Examples for paragraph (d)—*

- a place for inspecting by the Queensland Police Service
- a place for obtaining a gas certificate
- a place for having an identifying number stamped

- (5) For subsection (3)(a), the person may drive or tow the vehicle for testing to confirm the safe operation of the vehicle as part of an inspection mentioned in subsection (4)(a).

[s 81]

---

(6) In this section—

*relevant register* means—

- (a) the register; or
- (b) a register kept under a corresponding law to this regulation.

## **Division 3                      Written-off vehicle inspections**

### **81            Definition for div 3**

In this division—

*approval* means an approval of a person as—

- (a) an approved written-off vehicle examiner; or
- (b) an approved written-off vehicle nominee.

### **82            Approvals**

(1) A person may apply to the chief executive for an approval.

*Note—*

See part 10, division 3A, subdivision 2 for requirements about the application.

- (2) Subject to section 109D(4) and (5), the chief executive must consider an application for an approval within 28 days after it is received and decide either to—
  - (a) grant the approval; or
  - (b) refuse to grant the approval.
- (3) If the chief executive decides an applicant is a suitable person for an approval, the chief executive must, promptly after making the decision, grant the approval.

---

### **83 Conditions of approval**

An approval may be granted subject to conditions, including—

- (a) for an approval of a person as an approved written-off vehicle examiner—
  - (i) a condition that the approved written-off vehicle examiner may only perform written-off vehicle inspections while employed or otherwise engaged by a person contracted by the chief executive to operate a written-off vehicle inspection site; and
  - (ii) conditions about the way the approved written-off vehicle examiner is to perform written-off vehicle inspections; or
- (b) for an approval of a person as an approved written-off vehicle nominee—
  - (i) a condition that the approved written-off vehicle nominee may only supervise the day-to-day running of written-off vehicle inspections while employed or otherwise engaged by a person contracted by the chief executive to operate a written-off vehicle inspection site; and
  - (ii) conditions about the way the approved written-off vehicle nominee is to supervise the day-to-day running of written-off vehicle inspections.

### **84 Granting or refusing to grant approval**

- (1) If the chief executive decides to grant the approval, the chief executive must give written notice to the applicant of the decision promptly after making the decision.
- (2) The notice must state—
  - (a) any conditions to which the approval is subject; and
  - (b) that the applicant may ask for the decision to impose the conditions to be reviewed under section 111.

[s 85]

---

- (3) If the chief executive decides to refuse to grant the approval, the chief executive must give written notice to the applicant of the decision promptly after making the decision.
- (4) The notice must state—
  - (a) the reasons for the refusal; and
  - (b) that the applicant may ask for the decision to be reviewed under section 111.

**85 Approval prescribed for Act, ss 17B(2) and 18(1)(c)(ii)**

An approval under this division is prescribed for sections 17B(2) and 18(1)(c)(ii) of the Act.

**Division 4 Offences relating to written-off vehicle inspections**

**86 Performing written-off vehicle inspection when not approved**

A person must not perform, or purport to perform, a written-off vehicle inspection unless the person is an approved written-off vehicle examiner.

Maximum penalty—80 penalty units.

**87 Supervising written-off vehicle inspections when not approved**

A person must not supervise, or purport to supervise, the running of written-off vehicle inspections unless the person is an approved written-off vehicle nominee.

Maximum penalty—80 penalty units.

**88 Not complying with conditions of approval**

A person holding an approval must comply with any conditions stated in the approval.

Maximum penalty—80 penalty units.

**89 False or misleading written-off vehicle inspection report**

A person must not knowingly or recklessly give a written-off vehicle inspection report to another person that is false or misleading in a material particular.

Maximum penalty—80 penalty units.

**90 Operating place as a written-off vehicle inspection site**

A person must not operate, or purport to operate, a place as a written-off vehicle inspection site unless the person is contracted by the chief executive to operate the place as a written-off vehicle inspection site.

Maximum penalty—80 penalty units.

**91 Performing written-off vehicle inspection at place other than written-off vehicle inspection site**

An approved written-off vehicle examiner must not perform a written-off vehicle inspection at a place other than a place operated by a person contracted by the chief executive to operate the place as a written-off vehicle inspection site.

Maximum penalty—80 penalty units.

**92 Supervising written-off vehicle inspections at place other than written-off vehicle inspection site**

An approved written-off vehicle nominee must not supervise the running of written-off vehicle inspections at a place other than a place operated by a person contracted by the chief executive to operate the place as a written-off vehicle inspection site.

Maximum penalty—80 penalty units.

### **93 False advertising or holding out**

A person must not falsely advertise or hold out that a particular place is a place where written-off vehicle inspections may be performed.

Maximum penalty—80 penalty units.

## **Part 9 Measures for natural disasters or droughts**

### **Division 1 Measures for natural disasters**

#### **94 Application of div 1**

- (1) This division applies in relation to the registration, or renewal of registration, of a vehicle while a natural disaster relief notice is in effect for the vehicle.
- (2) A natural disaster relief notice is in effect for a vehicle if, during the period for which the notice has effect, all or part of the postcode area of the vehicle's garage address is in the area to which the notice applies.
- (3) In this section—  
*postcode area*, for a postcode, means the whole of the area to which the postcode applies.

#### **95 Definitions for div 1**

In this division—

*natural disaster relief notice* see section 96(2).

*Personal Hardship Assistance Scheme* means the scheme called the 'Personal Hardship Assistance Scheme' under which financial assistance may be granted to an individual under the disaster relief arrangements of the State or the Commonwealth.



---

**96 Natural disaster relief notice**

- (1) This section applies if the Personal Hardship Assistance Scheme is activated for an area (the *assistance scheme area*).
- (2) The chief executive may, by notice published on a Queensland Government website (a *natural disaster relief notice*), activate the measures for natural disasters under this division for all or part of the assistance scheme area.
- (3) The natural disaster relief notice must state—
  - (a) the part of the assistance scheme area to which the notice applies; and
  - (b) the period the notice has effect.
- (4) In this section—

*Queensland Government website* means a website with a URL that contains ‘qld.gov.au’, other than the website of a local government.

**97 Reduced term of registration or renewal of registration**

- (1) The vehicle may be registered for a term of 3 months, or the vehicle’s registration may be renewed for a term of 3 months.
- (2) This section applies in addition to section 22.

**98 Exemption from surcharge for reduced registration term or from administrative fee for late payment**

The applicant for registration or renewal of registration of the vehicle is exempt from paying—

- (a) any surcharge that would otherwise be payable by the applicant under schedule 3, item 7, 8, 9 or 10 for the application; and
- (b) for an application for renewal of registration—any administrative fee for late payment that would otherwise be payable for the application.

[s 99]

---

## **99 Seasonal registration—deferral of registration**

- (1) This section applies if the vehicle is a prescribed vehicle—
  - (a) owned by a primary producer and used only in the registered operator’s business as a primary producer; or
  - (b) used only seasonally, and only to transport primary produce from a farm or fishing waters to where the primary produce is—
    - (i) loaded onto a train, vessel or another vehicle; or
    - (ii) stored before being processed; or
    - (iii) the subject of the first processing step applied to it;  
or
    - (iv) processed.
- (2) The registration of the vehicle may be—
  - (a) deferred at the end of the registration term for a period of not more than 2 years; and
  - (b) renewed during, or at the end of, the deferral period.
- (3) This section applies despite section 23(3).

## **100 Section 97, 98 or 99 may be relied on only once**

To remove any doubt, it is declared that each of sections 97, 98 and 99 may be relied on for a vehicle only once while a particular natural disaster relief notice is in effect for the vehicle.

## **Division 2 Measures for droughts**

### **100A Application of div 2**

- (1) This division applies in relation to the registration, or renewal of registration, of an eligible vehicle during the eligibility period for the vehicle.
- (2) A vehicle is an *eligible vehicle* if the vehicle—

- 
- (a) has its garage address—
- (i) in a drought-declared area or at a drought-declared property; or
  - (ii) in an area that has stopped being a drought-declared area and for which a drought relief measure was relied on while the area was a drought-declared area; or
  - (iii) at a property that has stopped being a drought-declared property and for which a drought relief measure was relied on while the property was a drought-declared property; and
- (b) for which the register records the vehicle's purpose of use as private purposes or farming purposes; and
- (c) is not—
- (i) a conditionally registered vehicle; or
  - (ii) a vehicle, with distance and road use limits imposed by the chief executive, owned by a primary producer and used only in the owner's business as a primary producer.
- (3) The ***eligibility period*** for an eligible vehicle is the period—
- (a) while the vehicle's garage address is in a drought-declared area or at a drought-declared property; and
  - (b) ending 1 year after the area or property that the vehicle's garage address is in or at stopped being a drought-declared area or drought-declared property.
- (4) In this section—
- drought relief measure***, for a vehicle, means—
- (a) for a vehicle other than a prescribed vehicle—a measure provided for by section 100C or 100D; and
  - (b) for a prescribed vehicle—a measure provided for by section 100F.

[s 100B]

---

## **100B Definitions for div 2**

In this division—

***drought declaration*** means an official acknowledgement by the State or Commonwealth that an area or property is drought-stricken.

***drought-declared area*** means an area for which a drought declaration is in force.

***drought-declared property*** means a property for which a drought declaration is in force.

***required evidence or notice*** means—

- (a) for a vehicle with a garage address in a drought-declared area or at a drought-declared property—written evidence that the garage address for the vehicle is in the area or at the property; or
- (b) for a vehicle with a garage address in an area or at a property that has stopped being a drought-declared area or drought-declared property—written notice that—
  - (i) the applicant has complied with paragraph (a) for the vehicle; and
  - (ii) the vehicle’s garage address is in the area or at the property.

## **100C Reduced term of registration or renewal of registration**

- (1) The vehicle may be registered for a term of 3 months, or the vehicle’s registration may be renewed for a term of 3 months, during the period of 1 year from and including—
  - (a) for registration—the day of registration of the vehicle; or
  - (b) for renewal of registration—the day of renewal of registration of the vehicle in relation to which the required evidence or notice is given under section 100E.
- (2) This section applies in addition to section 22.

---

**100D Exemption from surcharge for reduced registration term or from administrative fee for late payment**

- (1) For the period mentioned in subsection (2), the applicant is exempt from paying—
  - (a) any surcharge that would otherwise be payable by the applicant under schedule 3, item 7, 8, 9 or 10 for the application; and
  - (b) for an application for registration—any administrative fee for late payment that would otherwise be payable by the applicant for the application.
- (2) For subsection (1), the period is 1 year from and including—
  - (a) if section 100E is complied with in relation to the registration of the vehicle—the day of registration; or
  - (b) if section 100E is complied with in relation to the renewal of registration of the vehicle—the day of the renewal.

**100E Required evidence or notice must be given**

- (1) An application for registration, or renewal of registration, of the vehicle made in reliance on section 100C or 100D must be accompanied by the required evidence or notice.
- (2) Subsection (1) does not apply if the applicant has previously complied with the subsection in relation to an application for registration, or renewal of registration, of the vehicle for the period of 1 year from and including—
  - (a) for a previous application for registration—the day of registration of the vehicle; or
  - (b) for a previous application for renewal of registration—the day of renewal of registration of the vehicle.
- (3) This section applies in addition to sections 13(1) and 43(1A).

[s 100F]

---

### **100F Seasonal registration—deferral of registration**

- (1) This section applies if the vehicle is a prescribed vehicle—
  - (a) owned by a primary producer and used only in the registered operator’s business as a primary producer; or
  - (b) used only seasonally, and only to transport primary produce from a farm or fishing waters to where the primary produce is—
    - (i) loaded onto a train, vessel or another vehicle; or
    - (ii) stored before being processed; or
    - (iii) the subject of the first processing step applied to it; or
    - (iv) processed.
- (2) The registration of the vehicle may be—
  - (a) deferred at the end of the registration term for a period of not more than 2 years; and
  - (b) renewed during, or at the end of, the deferral period.
- (3) However, a person who wants to defer registration of a vehicle for longer than 1 year but not longer than 2 years, and then renew the registration, must give the chief executive the required evidence or notice.
- (4) This section applies despite section 23(3).

## **Division 3                      Measure for transport of fodder for disaster or drought-affected primary producer**

### **100G Transport of fodder by primary producer for another primary producer**

- (1) A primary producer who is granted concessional registration for a primary production vehicle may use the vehicle, or permit the vehicle to be used, to transport fodder—

- (a) for another primary producer who has been granted disaster relief financial assistance in relation to an address—if the fodder is transported within 1 year after the day the other primary producer is granted the disaster relief financial assistance; or
- (b) for another primary producer—
  - (i) who is the registered operator of a vehicle that has its garage address in a drought-declared area or at a drought-declared property; or
  - (ii) who is the registered operator of a vehicle that had its garage address in a drought-declared area —if the fodder is transported within 1 year after the area stopped being a drought-declared area; or
  - (iii) who is the registered operator of a vehicle that had its garage address at a drought-declared property—if the fodder is transported within 1 year after the property stopped being a drought-declared property.
- (2) Subsection (1) applies only if the transport of the fodder is not done for reward or under a commercial arrangement.
- (3) In this section—

***disaster relief financial assistance*** means financial assistance granted by the State or Commonwealth to a person in relation to an address because of a disaster.

***drought-declared area*** see section 100B.

***drought-declared property*** see section 100B.

***reward*** does not include an expense incurred in transporting fodder.

## **Part 10**                      **Miscellaneous**

### **Division 1**                      **Other provisions about number plates**

#### **101**      **Replacing damaged, destroyed, lost or stolen number plates**

- (1) This section applies if a number plate for a registered vehicle has been damaged, destroyed, lost or stolen.
- (2) The registered operator of the vehicle must apply to the chief executive for a replacement of the number plate within 14 days after discovering the number plate has been damaged, destroyed, lost or stolen.

Maximum penalty—6 penalty units.

*Note—*

See part 10, division 3A, subdivision 2 for requirements about the application.

- (3) The application must be accompanied by—
  - (a) the relevant plate fee; and
  - (b) either—
    - (i) for the replacement of a damaged number plate—the damaged number plate; or
    - (ii) for the replacement of a destroyed, lost or stolen number plate—a statement giving details of the destruction, loss or theft.

*Note—*

See part 10, division 3A, subdivision 3 for requirements about the statement.

- (4) On receipt of the application, the chief executive may, subject to section 109D(4) and (5)—
  - (a) record in the register—
    - (i) the day the application was received; and



- 
- (ii) the damage, destruction, loss or theft of the number plate; and
  - (b) issue a replacement number plate.
- (5) If a number plate is replaced by a number plate with a new number, the chief executive may issue an updated registration certificate that contains the new number.
- (6) Until the replacement number plate is issued, the registered operator must attach any remaining plate to the rear of the vehicle.

Maximum penalty—12 penalty units.

- (7) The number plate being replaced stops being effective on the issue of the replacement number plate, and the replacement number plate becomes the current number plate for the vehicle.
- (8) The registered operator of the vehicle must immediately return to the chief executive a number plate that was lost or stolen if the registered operator recovers the number plate after the chief executive has issued a replacement number plate for it.

Maximum penalty—20 penalty units.

### **101A Replacing unlawfully copied number plates**

- (1) This section applies if a number plate lawfully issued for a registered vehicle has been unlawfully copied.
- (2) The registered operator of the vehicle may apply to the chief executive for a replacement number plate.

*Note—*

See part 10, division 3A, subdivision 2 for requirements about the application.

- (3) The application must be accompanied by—
- (a) the number plate lawfully issued for the registered vehicle; and
  - (b) a statement about the unlawful copying.

[s 102]

---

*Note—*

See part 10, division 3A, subdivision 3 for requirements about the statement.

- (4) On receipt of the application, the chief executive may, subject to section 109D(4) and (5)—
  - (a) record in the register—
    - (i) the day the application was received; and
    - (ii) details of the unlawful copying; and
  - (b) issue a replacement number plate and an updated registration certificate.
- (5) The number plate being replaced stops being effective on the issue of the replacement number plate, and the replacement number plate becomes the current number plate for the vehicle.
- (6) No fee is payable for an application under subsection (2).
- (7) In this section—

***replacement number plate*** does not include a personalised number plate.

## **102 Chief executive may require exchange of number plates**

- (1) This section applies if the chief executive—
  - (a) considers any writing, word or image displayed on a number plate is any of the following—
    - (i) obscene;
    - (ii) indecent;
    - (iii) contrary to the public interest;
    - (iv) likely to cause offence to a reasonable person; or
  - (b) considers the number of a number plate is identical, or appears to be identical, to the number of another number plate that is currently issued; or
  - (c) considers a number plate was issued in error; or

- 
- (d) changes the specifications to which a number plate is manufactured; or
  - (e) considers any writing, word or image displayed on a number plate is likely to—
    - (i) infringe the intellectual property rights of a person other than the State; or
    - (ii) give rise to a cause of action for passing off or defamation; or
    - (iii) contravene the Australian Consumer Law (Queensland), section 18, 29 or 37.
- (2) The chief executive may, by written notice given to a person who is recorded in the register as the person who was issued or who acquired the number plate, require the person to return the number plate (the *original plate*) to the chief executive within the time stated in the notice to be exchanged for another number plate.
- (3) The notice must state the chief executive's reason for requiring the return of the original plate.
- (4) The person must not contravene the requirement unless the person has given the chief executive notice the original plate has been lost, stolen or destroyed.

Maximum penalty—20 penalty units.

*Note—*

See part 10, division 3A, subdivision 3 for requirements about the notice.

- (5) The chief executive must record in the register the exchange of the original plate for a replacement number plate if the original plate is—
- (a) returned under this section; or
  - (b) delivered to an authorised officer under section 128(1)(d); or
  - (c) under section 128A, removed and recovered by an authorised officer on the basis that a requirement was made under section 128(1)(d).

- (6) On the exchange—
  - (a) the original plate stops being effective; and
  - (b) the replacement number plate becomes the current number plate for the vehicle.

### **103 Chief executive may require return of number plates**

- (1) This section applies if the chief executive reasonably believes—
  - (a) a number plate is being used, or has been used, in contravention of this regulation; or
  - (b) a number plate was issued as the number plate for a limousine or taxi and the limousine or taxi is no longer operating under the licence issued under the *Transport Operations (Passenger Transport) Act 1994*.
- (2) The chief executive may, by written notice, require the person to whom the number plate was issued to return the plate to the chief executive within 14 days of the date of the notice (the *return period*).
- (3) The person must return the number plate to the chief executive within the return period.

Maximum penalty—20 penalty units.

- (4) However, if the number plate has been lost, stolen or destroyed, the person does not contravene subsection (3) if the person, within the return period, notifies the chief executive of the details of the loss, theft or destruction.

*Note—*

See part 10, division 3A, subdivision 3 for requirements about the notice.

- (5) The chief executive must record the return of the number plate in the register.
- (6) If this section applies because of subsection (1)(b)—
  - (a) the chief executive may, in the written notice given to a person under subsection (2), also require that the

- 
- number plate, when returned, be exchanged for a new number plate that is not issued as the number plate for a limousine or taxi; and
- (b) if the number plate is not returned within the return period, the chief executive may issue a replacement number plate for the vehicle that is not issued as the number plate for a limousine or taxi.
- (7) On the exchange, or the issue of the number plate for the vehicle under subsection (6)(b)—
- (a) the number plate being replaced stops being effective; and
  - (b) the replacement number plate becomes the current number plate for the vehicle.

## **104 Property in number plates**

- (1) Subject to subsections (2) and (3), a number plate issued by the chief executive remains the property of the State.
- (2) A national heavy vehicle number plate issued by the State remains the property of the State unless the vehicle to which the plate relates is registered in another State under a corresponding law to this regulation.
- (3) A national heavy vehicle number plate issued by another State under a corresponding law to this regulation becomes the property of the State when the vehicle to which the plate relates is registered under this regulation.
- (4) Subsection (1) applies even if, under section 33(3), the right to use the number on the number plate is the property of the person to whom the plate was issued.

## **Division 2 Vehicles temporarily in Queensland**

### **105 Vehicles temporarily in Queensland**

- (1) This section applies to a vehicle if the vehicle—

[s 105]

---

- (a) does not have a garage address in Queensland or has had a garage address in Queensland for not more than 14 days; and
  - (b) is to be used on a road; and
  - (c) either—
    - (i) the vehicle is registered in—
      - (A) another State under a corresponding law to this regulation; or
      - (B) a foreign country under a law of the country about the registration of vehicles used on roads; or
    - (ii) the vehicle is not registered in a way mentioned in subparagraph (i), but may be used on a road under an authority or permit in force under a law of another State relating to the use of unregistered vehicles, including a law relating to dealer plates.
- (2) The vehicle may be used on a road if—
- (a) the vehicle carries and displays all number plates it is required to carry and display in the way required by the law—
    - (i) for a vehicle mentioned in subsection (1)(c)(i)—of the other State or foreign country; or
    - (ii) for a vehicle mentioned in subsection (1)(c)(ii)—of the other State; and
  - (b) for a vehicle mentioned in subsection (1)(c)(ii)—the vehicle is used under the relevant authority or permit, so far as it is capable of being applied to the use of the vehicle outside the other State; and
  - (c) the vehicle is insured—
    - (i) for a vehicle registered in a foreign country—under the *Motor Accident Insurance Act 1994*; or

- 
- (ii) for a vehicle registered in, or used under an approval issued by, another State—under a contract of insurance made under a law of the other State similar to the *Motor Accident Insurance Act 1994*.
- (3) The owner or person in charge of the vehicle must ensure that when the vehicle is used on a road the owner or person is able to produce for inspection on demand by an authorised officer—
- (a) for a vehicle registered in a foreign country—each of the following—
- (i) proof of the vehicle’s current registration;
  - (ii) proof of a current CTP insurance policy for the vehicle;
  - (iii) if the vehicle is present in Australia under a temporary admission carnet—proof of the temporary admission carnet;
  - (iv) if the importation of the vehicle was approved under a status of forces agreement—proof of the approval;
  - (v) if the vehicle is a heavy vehicle that has the centre of a steering control to the left of the vehicle—the left-hand drive permit for the vehicle.
- (b) otherwise—the approval to use the vehicle under the law of the other State.

Maximum penalty—8 penalty units.

- (4) A category 2 vehicle’s garage address is taken to be an address in Queensland if the vehicle is used continuously in Queensland for more than 3 months.
- (5) In this section—

***CTP insurance policy*** see the *Motor Accident Insurance Act 1994*, section 4.

***left-hand drive permit***, for a heavy vehicle, means a permit, granted under Chapter 3, Part 3.2, Division 3 of the Heavy

[s 105A]

---

Vehicle National Law (Queensland), exempting the vehicle from compliance with schedule 2, section 4(1) of the *Heavy Vehicle (Vehicle Standards) National Regulation*.

***status of forces agreement*** means an agreement between the Commonwealth and another country allowing for the importation of vehicles by visiting military personnel.

***temporary admission carnet*** means a document that is, or is of the same nature as, a carnet de passages en douane, relating to the presence in Australia of a vehicle registered in another country.

## **Division 3                      Other miscellaneous provisions**

### **105A Vehicle registered in another State in name of defence force member or eligible family member**

- (1) This section applies to a vehicle if—
  - (a) the vehicle is registered in another State, under a law corresponding to this regulation (the ***corresponding law***), in the name of a defence force member or an eligible family member of a defence force member; and
  - (b) the defence force member starts residing in Queensland because of a transfer arranged by the Australian Defence Force.
- (2) The vehicle may be used on a road if—
  - (a) the vehicle carries and displays, in the way required by the corresponding law, all number plates it is required to carry and display under the corresponding law; and
  - (b) the vehicle is insured under a contract of insurance made under a law of the other State similar to the *Motor Accident Insurance Act 1994*.
- (3) Subsection (2) stops applying on the expiry of the registration of the vehicle, under the corresponding law, in effect at the time of the transfer mentioned in subsection (1)(b).



(4) In this section—

*eligible family member*, of a defence force member, means a person who—

- (a) usually resides with the defence force member; and
- (b) is entitled to be transferred with the defence force member at the expense of the Australian Defence Force.

## **106 Sale of unregistered vehicles by dealers**

(1) A dealer must not deliver an unregistered vehicle to a purchaser, other than another dealer, on the sale of the vehicle unless an application to register the vehicle under this regulation has been made.

Maximum penalty—40 penalty units.

(2) However, the dealer does not contravene subsection (1) if the dealer obtains a written statement from the purchaser that—

- (a) the vehicle is not to be used on a road; or
- (b) the vehicle's garage address will not be in Queensland.

(3) The dealer must keep a statement received under subsection (2) for at least 1 year after the day of delivery of the vehicle to the purchaser.

Maximum penalty—8 penalty units.

## **107 Authorisation to use unregistered vehicle on roads**

(1) A person may apply to the chief executive for an authorisation to use on a road an unregistered vehicle, or class of unregistered vehicle, including a vehicle or class of vehicle that does not conform with the requirements applying to the vehicle or class under a vehicle law.

*Note—*

See part 10, division 3A, subdivision 2 for requirements about the application.

[s 107]

---

- (1A) However, a person may not apply under subsection (1) for an authorisation to use on a road an unregistered vehicle that is a heavy vehicle, or a class of unregistered vehicle to the extent the class includes a heavy vehicle, if the heavy vehicle does not conform with the requirements applying to the vehicle under a vehicle law.
- (2) Subject to section 109D(4) and (5), the chief executive may grant the authorisation only if the chief executive is satisfied the use of the vehicle, or class of vehicle, on the road would not—
- (a) adversely affect road safety; or
  - (b) inconvenience other road users.
- (3) Before granting the authorisation, or as a condition of it, the chief executive may require the applicant to pay the chief executive's costs or estimated costs of the following—
- (a) assessing the vehicle's route and preparing the relevant plans and estimates;
  - (b) preparing and strengthening road transport infrastructure on the route;
  - (c) repairing, replacing or reconstructing road transport infrastructure on the route;
  - (d) ensuring compliance with a condition or a proposed condition of the authorisation.
- (3A) Subsection (3) does not apply to an authorisation to use on a road—
- (a) an unregistered vehicle that is a heavy vehicle; or
  - (b) a class of unregistered vehicle to the extent the class includes a heavy vehicle.
- (4) The authorisation must be in writing and state the following particulars—
- (a) the vehicle or class of vehicle to which it applies;
  - (b) the roads where the vehicle may be used;
  - (c) the term, not longer than 5 years, for which it is issued;

- (d) the conditions, if any, on which it is issued.
- (5) If the authorisation is issued on a condition, it is void if the condition is contravened.

## **108 Permit to use intercepted unregistered vehicle on road**

- (1) This section applies if an authorised officer finds on a road—
  - (a) a stationary unregistered vehicle; or
  - (b) an unregistered vehicle that has been stopped under—
    - (i) section 31 or 32 of the Act; or
    - (ii) the *Police Powers and Responsibilities Act 2000*; or
    - (iii) the Heavy Vehicle National Law (Queensland).
- (2) The authorised officer may issue a permit authorising the use of the vehicle on roads to move it to a stated place if the officer has—
  - (a) issued an infringement notice or notice to appear for a contravention of section 11; or
  - (b) completed a report for dealing with the contravention at a later time.
- (3) The permit must—
  - (a) be in the approved form; and
  - (b) state the term, not longer than 24 hours, for which it is issued; and
  - (c) state the conditions, if any, on which it is issued; and
  - (d) state—
    - (i) if subsection (2)(a) applies—the number of the infringement notice or notice to appear; or
    - (ii) if subsection (2)(b) applies—that the contravention of section 11 is to be dealt with at a later time either by issuing an infringement notice or notice

to appear or by taking a proceeding by complaint and summons under the *Justices Act 1886*.

- (4) If the permit is issued on a condition, it is void if the condition is contravened.

- (5) In this section—

*infringement notice* means an infringement notice under the *State Penalties Enforcement Act 1999*.

*notice to appear* means a notice to appear under the *Police Powers and Responsibilities Act 2000*.

## 109 Damaged or dirty number plates

- (1) This section applies if a vehicle's number plate is—
- (a) damaged and not legible; or
  - (b) dirty and not legible.
- (2) An authorised officer may, by written notice given to the registered operator of the vehicle, or to a person in charge of the vehicle, require the registered operator to—
- (a) for a damaged number plate—apply to the chief executive, within the time stated in the notice, for a replacement number plate under section 101; or
  - (b) for a dirty number plate—
    - (i) clean the number plate; and
    - (ii) bring the vehicle to the chief executive to be inspected within the time stated in the notice.
- (3) If the person to whom the notice is given is not the registered operator of the vehicle, the person to whom the notice is given must immediately give the notice to the registered operator of the vehicle, unless the person has a reasonable excuse.

Maximum penalty—6 penalty units.

- (4) The registered operator must not contravene a requirement under subsection (2) unless the registered operator has a reasonable excuse.

---

Maximum penalty—6 penalty units.

- (5) Despite anything else in this regulation, a person who uses, or permits to be used, a vehicle on a road when a number plate required under this regulation to be attached to the vehicle is not attached to the vehicle does not commit an offence if—
- (a) the number plate is damaged; and
  - (b) an authorised officer, acting under subsection (2)(a), has given the registered operator of the vehicle a written notice directing the registered operator to apply to the chief executive for a replacement number plate under section 101; and
  - (c) the damaged number plate and the written notice are being carried in the vehicle; and
  - (d) the vehicle is being driven to a place for the purpose of applying, at the place, to the chief executive for a replacement number plate under section 101.

## **Division 3A            Requirements for particular applications etc.**

### **Subdivision 1        Preliminary**

#### **109A    Definitions for division**

In this division—

*application* means an application to the chief executive under a provision of this regulation.

*customer communication*—

- (a) means each of the following—
  - (i) a notice, however described, required to be given by a person to the chief executive under a provision of this regulation;

[s 109B]

---

- (ii) a notice given to the chief executive under section 34(2A) or 48(6)(b);
  - (iii) a direction under section 42(1)(a)(i);
  - (iv) a statement under section 48(5), 50(3), 101(3)(b)(ii) or 101A(3)(b);
  - (v) a request for information under section 115(1)(a);
  - (vi) the giving of notifiable information under section 69(1); but
- (b) does not include the giving of required evidence or notice under section 100E or 100F.

*information* includes a document.

## **Subdivision 2 Particular applications**

### **109B Chief executive may publish a notice about applications**

- (1) The chief executive may, by publishing a notice on the department's website—
- (a) approve a way in which a stated type of application may be made; or
- Examples of ways—*
- orally, by electronic communication or by another form of communication
- (b) require stated information to be given in or with a stated type of application.
- (2) A notice under subsection (1)(a) may include requirements for making an application in the approved way.
- (3) A notice under subsection (1)(b) may only require information that is reasonably necessary for—
- (a) the purpose of enabling the chief executive to decide the application; or
  - (b) another purpose related to the application or the thing being applied for.

*Example—*

Required information may not include—

- (a) irrelevant personal information; or
  - (b) relevant personal information if the provision of the information would be excessively intrusive to personal privacy.
- (4) Subsection (1) applies whether or not there is an approved form for making the application.

### **109C How applications must be made**

- (1) An application must be made in any of the following ways—
  - (a) in the approved form for the application;
  - (b) in the way approved under section 109B(1)(a) for making the application; or
  - (c) if there is no approved form and no approved way for making the application—in writing.
- (2) An application must include any information required under section 109B(1)(b).
- (3) Subsection (2) does not limit another provision of this regulation that requires an application to include, or be accompanied by, particular information.

### **109D Chief executive may request further information**

- (1) The chief executive may give an applicant a written notice asking for further information that the chief executive reasonably needs to decide the applicant's application.
- (2) The notice—
  - (a) must state—
    - (i) the information required; and
    - (ii) the time, no earlier than 28 days after the notice is given, by which the information is required to be given; and

[s 109E]

---

- (iii) that, if the applicant does not comply with the notice, the chief executive may cancel the application; and
  - (b) may state a way in which the information is required to be given.
- (3) If the notice does not state a way in which the information is required to be given, the applicant must give the information in writing.
- (4) If the applicant does not comply with the notice, the chief executive may give the applicant a further notice cancelling the application.
- (5) A notice cancelling the application has effect on the day it is given to the applicant or any later day stated in it.

### **Subdivision 3 Particular customer communications**

#### **109E Chief executive may publish a notice about particular customer communications**

- (1) The chief executive may, by publishing a notice (a *departmental notice*) on the department's website—
  - (a) approve a way in which a stated customer communication may be given or made; or
    - Examples of ways—*
      - orally, by electronic communication or by another form of communication
  - (b) require stated information to be given in or with a stated customer communication.
- (2) A departmental notice may include requirements for giving or making a customer communication in the approved way.
- (3) Subsection (1) applies whether or not there is an approved form for giving or making of the customer communication.



---

## **109F How customer communications must be given or made**

- (1) A customer communication must be given or made in any of the following ways—
  - (a) in the approved form for the customer communication;
  - (b) in the way approved under section 109E(1)(a) for giving or making the customer communication; or
  - (c) if there is no approved form and no approved way for giving or making the customer communication—in writing.
- (2) A customer communication must include, or be accompanied by, any information required under section 109E(1)(b).
- (3) Subsection (2) does not limit another provision of this regulation that requires a customer communication to include, or be accompanied by, particular information.

## **Division 4 Review of decisions**

### **110 Decisions to which this division applies**

This division applies to a decision of the chief executive made under this regulation if the decision is one of the following—

- (a) a decision not to register a vehicle, other than—
  - (i) a decision not to register a vehicle that is a statutory write-off; or
  - (ii) a decision made under section 17(1A);
- (b) a decision not to renew the registration of a vehicle, other than—
  - (i) a decision not to renew the registration of a vehicle that is a statutory write-off; or
  - (ii) a decision made under section 43(11)(b);
- (c) a decision not to record in the register the transfer of the registration of a vehicle;

[s 111]

---

- (d) a decision not to authorise the use of a vehicle on a road under an unregistered vehicle permit;
- (e) a decision to refuse to issue an overseas vehicle permit for a vehicle under section 105;
- (f) a decision to refuse to grant an approval to a person under part 8, division 3;
- (g) a decision to impose a condition on an approval under section 83;
- (h) a decision to refuse to approve a motorbike as a learner approved motorbike;
- (i) a decision to refuse an authorisation under section 107 to use on a road a vehicle or a class of vehicle.

## 111 Review of decision

- (1) Sections 65 and 65A of the Act apply to a division 4 decision as if a reference to an original decision in section 65 of the Act were a reference to the division 4 decision.

- (2) In this section—

*division 4 decision* means a decision to which this division applies as mentioned in section 110.

## Division 5 Release of information

### 112 Definitions for div 5

In this division—

*client user*, of a public access provider, means a lawyer, insurance company, insolvency entity or statutory entity—

- (a) who has entered into a public access agreement with a public access provider; and
- (b) who has been approved by the chief executive, before or after the commencement of this section, as a suitable

---

entity to obtain extracts from the register of information about vehicles, using online computer access; and

- (c) whose approval as a suitable entity has not been withdrawn.

**compensation order**, for a victim of crime, means an order requiring the payment of compensation made under the following—

- (a) section 24 of the repealed Criminal Offence Victims Act;
- (b) section 663B of the repealed Criminal Code chapter.

*Note—*

See also the *Victims of Crime Assistance Act 2009*, chapter 6.

**eligible person** means—

- (a) an involved person; or
- (b) a statutory entity; or
- (c) the registered operator of a vehicle seeking information from the register about the vehicle; or
- (d) a safety recall agency; or
- (e) a person seeking information from the register about a vehicle with the written consent of the registered operator of the vehicle; or
- (f) an insolvency entity; or
- (g) a victim of crime seeking information from the register in relation to obtaining payment under the person's compensation order.

**give**, in relation to information, includes allowing a person to obtain the information.

**insolvency entity** means an entity exercising powers—

- (a) under the *Bankruptcy Act 1966* (Cwlth) in relation to bankruptcy; or
- (b) under the provisions of the Corporations Act relating to external administration.

[s 112]

---

***interstate register*** means a register kept by another State under a corresponding law to this regulation.

***involved person*** means a person who proposes to commence, or has commenced, litigation.

***litigation*** means a proceeding, or a proposed proceeding, in a court for which information in the register about a particular vehicle is, or may be, of relevance, but only if—

- (a) the proceeding is about—
  - (i) an incident on a road or somewhere else involving the vehicle; or
  - (ii) the bankruptcy or possible bankruptcy of the registered operator of the vehicle, or the application, or the possible application, to the registered operator of the vehicle, of the provisions of the Corporations Act relating to external administration; or
  - (iii) fraudulent activities of the registered operator of the vehicle; or
- (b) the proceeding is before the Family Court of Australia and involves the registered operator of the vehicle; or
- (c) in the course of the proceeding, the court decides information about the registered operator of the vehicle is required, including, for example, to help to finalise the proceeding.

***NEVDIS*** means the database known as the ‘National Exchange of Vehicle and Driver Information System’ that—

- (a) is operated under an arrangement among the State and other States; and
- (b) contains information about vehicles and drivers from registers kept by the States participating in the arrangement.

***personal information***, about a vehicle’s current or previous registered operator, means—

- (a) the person’s name and address; and

- 
- (b) if there is a current postal address for the person—the postal address; and
  - (c) any information that may identify the person.

***public access provider*** means—

- (a) the chief executive; or
- (b) a person who has entered into an agreement with the chief executive to provide online computer access to the register to entities approved by the chief executive.

***repealed Criminal Code chapter*** means the Criminal Code, chapter 65A, as it continued to apply from time to time under section 46(2) of the repealed Criminal Offence Victims Act.

***repealed Criminal Offence Victims Act*** means the repealed *Criminal Offence Victims Act 1995*, as in force from time to time before its repeal.

***safety recall agency*** means a vehicle manufacturer conducting a national vehicle safety recall program who requires details from the register to identify the registered operators of particular vehicles.

***statutory entity*** means—

- (a) a local government or other entity established under a statute enforcing a law about vehicles or about the parking of vehicles in an area under its control; or
- (b) an entity having lawful access, under another Act, or under administrative arrangements approved by the chief executive, to details kept by the chief executive in the register.

***vehicle-related information***, about a vehicle, means information about the vehicle from the register, or from an interstate register that is available to the chief executive through NEVDIS, but does not include—

- (a) for a vehicle currently recorded in the register or interstate register as a written-off vehicle—
  - (i) personal information about a current or previous registered operator of the vehicle; or

[s 115]

---

- (ii) information about a notifier that has given notifiable information for the vehicle; or
  - (iii) information about the location of, or the severity of, damage to the vehicle; or
- (b) for a vehicle not currently recorded in the register or interstate register as a written-off vehicle—personal information about a current or previous registered operator of the vehicle.

*vehicle-related information provider* see section 117(1).

*victim of crime* means a person in whose favour a court has made a compensation order.

## **115 Release of information on payment of amount or fee**

- (1) The chief executive may, in the circumstances approved by the chief executive, give an extract from the register of information about a vehicle to an eligible person, or a person acting on the eligible person's behalf, if the eligible person, or the person acting on the eligible person's behalf—
- (a) gives the chief executive a request for the information; and
- Note—*  
See part 10, division 3A, subdivision 3 for requirements about the request.
- (b) pays—
    - (i) if the eligible person is a statutory entity or safety recall agency—the amount, if any, provided for under section 115A for giving the extract; or
    - (ii) otherwise—the fee stated in schedule 3, part 4 for giving the extract.
- (2) The eligible person, or the person acting on the eligible person's behalf, must not use or disclose information obtained under subsection (1) other than under conditions approved by the chief executive for the use and disclosure of the information and advised to the eligible person or the person

---

acting on the eligible person's behalf when, or before, the information is obtained.

Maximum penalty—20 penalty units.

- (3) A public access provider may allow a client user of the provider to obtain an extract from the register of information about a vehicle, using online computer access, if the client user—
- (a) pays the public access provider—
    - (i) if the client user is a statutory entity—the amount, if any, provided for under section 115A for obtaining the extract; or
    - (ii) otherwise—the fee stated in schedule 3, part 4 for obtaining the extract; and
  - (b) obtains the extract only in the circumstances approved by the chief executive for obtaining the extract.
- (4) The client user must not use or disclose information obtained under subsection (3) other than under conditions approved by the chief executive for the use and disclosure of the information and advised to the client user when, or before, the information is obtained.

Maximum penalty—20 penalty units.

- (5) The information given under subsection (1) or obtained under subsection (3) may include personal information about the vehicle's current or previous registered operator.

### **115A Amount payable for release of information to particular entities**

- (1) This section provides for the amount to be paid to—
- (a) the chief executive under section 115(1)(b)(i) for an eligible person who is—
    - (i) a statutory entity; or
    - (ii) a safety recall agency; or

[s 116]

---

- (b) a public access provider under section 115(3)(a)(i) for a client user who is a statutory entity.
- (2) The amount is—
  - (a) for an extract given under section 115(1) to an eligible person who is—
    - (i) a statutory entity—the amount, if any, the chief executive decides is reasonable having regard to the relevant circumstances for giving the extract but no more than the amount of the fee stated in schedule 3, part 4 for giving the extract; or
    - (ii) a safety recall agency—nil; or
  - (b) for an extract obtained by a statutory entity under section 115(3)—the amount, if any, the chief executive decides is reasonable having regard to the relevant circumstances for obtaining the extract but no more than the amount of the fee stated in schedule 3, part 4 for obtaining the extract.
- (3) In this section—  
*relevant circumstances*, for giving or obtaining an extract, means how and why the extract is given or obtained.

## **116 Release of information to relevant tolling entities and other persons**

- (1) The chief executive may, under an arrangement in writing entered into between the chief executive and a toll road operator or local government tollway operator, give an extract from the register of information about a vehicle to—
  - (a) the operator; or
  - (b) a person acting for the operator.
- (2) Without limiting subsection (1), the chief executive may, under an arrangement in writing entered into between the chief executive and a local government, give an extract from a relevant register of information about a vehicle to—
  - (a) the local government; or



- (b) a person acting for the local government;  
for the purpose of the local government enforcing tolling offences committed in relation to a local government tollway in the local government's area.
- (3) An arrangement under subsection (1) or (2) must—
- (a) include conditions imposed by the chief executive about—
- (i) the giving of the information; and
- (ii) the use and disclosure of the information; and
- (b) provide for payment to the chief executive of the reasonable amount decided by the chief executive for giving the information.
- (4) A relevant tolling entity given information about a vehicle under an arrangement as mentioned in subsection (1) or (2) must not use or disclose the information other than under the conditions stated in the arrangement for the use and disclosure.

Maximum penalty—20 penalty units.

- (5) If a person who is acting for a relevant tolling entity is given information about a vehicle under an arrangement as mentioned in subsection (1) or (2), the person must not use or disclose the information other than under the conditions—
- (a) stated in the arrangement for the use and disclosure; and
- (b) advised to the person when, or before, the information is given.

Maximum penalty—20 penalty units.

- (6) Information about a vehicle that may be released under subsection (1) or (2) includes personal information about the vehicle's current or previous registered operator.
- (7) In this section—

***local government tollway*** see the *Transport Infrastructure Act 1994*, section 105GA(5).

[s 116A]

---

*local government tollway operator* see the *Transport Infrastructure Act 1994*, section 105B.

*relevant register* means—

- (a) the register; or
- (b) an interstate register that is available to the chief executive through NEVDIS.

*relevant tolling entity* means any of the following—

- (a) a toll road operator;
- (b) a local government tollway operator;
- (c) a local government with which the chief executive has entered into an arrangement under subsection (2).

*tolling offence* means an offence against the *Transport Infrastructure Act 1994*, section 105ZH(3), 105ZJ(4) or 105ZK(3).

*toll road operator* see the *Transport Infrastructure Act 1994*, section 92.

## **116A Release of information to entity that maintains NEVDIS**

- (1) The chief executive may, for the NEVDIS arrangement, give an extract from the register of information about a vehicle to the entity that maintains NEVDIS.
- (2) The information given under subsection (1) may include personal information about the vehicle's current or previous registered operator.
- (3) In this section—

*NEVDIS arrangement* means the arrangement mentioned in section 112, definition *NEVDIS*, paragraph (a).

## **117 Release of vehicle-related information**

- (1) This section applies to the following (each of whom is a *vehicle-related information provider*)—

- 
- (a) the chief executive;
  - (b) a person who has entered into an agreement with the chief executive that provides the person will give vehicle-related information about a vehicle to other persons.
- (2) A vehicle-related information provider may give a person vehicle-related information about a vehicle if—
- (a) the person pays the vehicle-related information provider the fee or amount provided for under section 118; and
  - (b) the information is given to the person only in the circumstances approved by the chief executive in relation to the giving of the information.
- (3) However, subsection (2)(a) does not apply to the chief executive in giving information to a person under section 116, 116A or 117A.

*Note—*

See section 116(3)(b) about payment to the chief executive for giving information to the person under that section.

- (4) A person given information under subsection (2) must not use or disclose the information other than under any conditions approved by the chief executive for the use or disclosure of the information and advised to the person when, or before, the information is given.

Maximum penalty for subsection (4)—20 penalty units.

### **117A Release of vehicle-related information for particular purposes**

- (1) The chief executive may provide vehicle-related information about a vehicle to a person if satisfied—
- (a) the information will inform the person about whether the vehicle is, or is not—
    - (i) registered; or
    - (ii) a high-powered vehicle; or

[s 117A]

---

- (iii) a learner approved motorbike; or
  - (b) the information will inform the person about the vehicle's purpose of use; or
  - (c) the person requires the information to inform himself or herself that the vehicle has, or does not have, a current inspection certificate under the Vehicle Standards and Safety Regulation; or
  - (d) the person is a specified person who requires the information in relation to an inspection certificate or inspection report under the Vehicle Standards and Safety Regulation for the vehicle; or
  - (e) the person is an approved person who requires the information to perform a function of an approved person.
- (2) In this section—

**approved person** means an approved person under the *Transport Operations (Road Use Management—Accreditation and Other Provisions) Regulation 2015*.

**high-powered vehicle** see the *Transport Operations (Road Use Management—Driver Licensing) Regulation 2010*, schedule 9.

**proprietor of an AIS** means a proprietor of an AIS under the *Transport Operations (Road Use Management—Accreditation and Other Provisions) Regulation 2015*.

**provide**, for vehicle-related information, includes—

- (a) providing the information—
  - (i) electronically; or
  - (ii) orally; and
- (b) allowing a person to access the information.

**specified person** means—

- (a) a proprietor of an AIS; or
- (b) an approved examiner; or

- 
- (c) a person authorised by a proprietor of an AIS to receive or obtain vehicle-related information.

## **118 Amount or fee payable to vehicle-related information provider**

- (1) This section provides for the amount or fee to be paid to a vehicle-related information provider under section 117(2)(a).
- (2) The amount or fee is—
  - (a) if the vehicle-related information provider is the chief executive and a fee is stated in schedule 3, part 4 for giving vehicle-related information about a vehicle—
    - (i) for vehicle-related information given to a statutory entity—the amount, if any, the chief executive decides is reasonable having regard to the relevant circumstances for giving the information but no more than the stated fee; or
    - (ii) otherwise—the stated fee; or
  - (b) if paragraph (a) does not apply—a reasonable amount decided by the vehicle-related information provider for giving vehicle-related information about a vehicle.
- (3) In this section—

*relevant circumstances*, for giving vehicle-related information about a vehicle, means how and why vehicle-related information is given or obtained.

## **Division 6 Use of information from register for particular purposes**

### **119 Use of information for contacting registered operator about moving or removing vehicle**

- (1) The chief executive may contact the registered operator of a vehicle before, during or after moving or removing the vehicle

[s 119A]

---

under section 51G of the Act for the purpose of advising the registered operator of—

- (a) the movement or intended movement of the vehicle; or
- (b) the removal or intended removal of the vehicle.

*Note—*

See section 5 (Meaning of *registered operator* in this regulation).

- (2) The chief executive may use prescribed information about the vehicle from the register for the purpose of contacting the registered operator under subsection (1).

*Note—*

See section 143 (Confidentiality) of the Act.

- (3) In this section—

**contact** includes contact by mail or phone, in person or in another way.

**prescribed information**, about a vehicle, means—

- (a) the name and address of the registered operator of the vehicle; and
- (b) if a postal address for the registered operator is contained in the register—the postal address; and
- (c) if a telephone number for the registered operator is contained in the register—the telephone number.

*Note—*

See section 18(7) about other information the chief executive may record in the register.

**registered operator**, of a vehicle that is not, but has been, registered, includes the previous registered operator of the vehicle.

## **119A Use of information for contacting registered operator about recovery of cost of damage**

- (1) This section applies if a person—
  - (a) is the registered operator of a vehicle; and

- 
- (b) may be liable under the *Transport Infrastructure Act 1994*, section 48(2) to pay an amount to the chief executive.
- (2) The chief executive may use prescribed information about the vehicle from the register to contact the person in relation to the liability mentioned in subsection (1)(b).
- (3) In this section—

**contact** means contact by mail or phone, in person or in another way.

**prescribed information**, about a vehicle, means—

- (a) the name and address of the registered operator of the vehicle; and
- (b) if a postal address for the registered operator is contained in the register—the postal address; and
- (c) if a telephone number for the registered operator is contained in the register—the telephone number.

*Note—*

See section 18(7) about other information the chief executive may record in the register.

## **Division 7                      When registration certificate may be made available electronically**

### **119B Making particular registration certificates electronically available**

- (1) This section—
- (a) applies if the chief executive is required to, or may, issue a registration certificate to a person; but
- (b) does not apply if the chief executive is required to issue a registration certificate for a vehicle mentioned in section 31(2), 33(5)(b) or 36(3)(b) to a person.

[s 120]

---

- (2) The way the chief executive may issue the registration certificate is by making the registration certificate available for the person to access electronically.
- (3) In this section—  
*issue* includes give.  
*registration certificate* includes updated registration certificate mentioned in section 21(1)(b), 32B(3)(b), 32C(3)(b), 48(8)(d), 50(5)(d), 101(5) and 101A(4)(b).

## **Part 11                      Fees**

### **Division 1                      General**

#### **120      Fees**

- (1) The registration fees payable for a category 1 vehicle are stated in schedule 1.
- (2) The registration fees payable for a category 2 vehicle are stated in schedule 2.
- (3) However, the amount of the registration fee payable for a category 2 vehicle stated in schedule 2, part 1 is the total of—
  - (a) the amount for the road use component; and
  - (b) the amount for the regulatory component.
- (4) Other fees payable under this regulation are stated in schedule 3.  
*Note—*  
See also part 10, division 5 for particular amounts relating to the release of information.
- (5) A fee payable under schedule 1, 2 or 3 that relates to the registration of a vehicle for a term—
  - (a) is the fee stated in the schedule for the financial year in which the term starts; and



- 
- (b) is to be adjusted in proportion to the number of days in the term if—
    - (i) the fee is a registration fee under schedule 1 or 2, a traffic improvement fee or a registration administration fee; and
    - (ii) the term is less than 1 year.

## 121 Charging categories

- (1) If a category 2 vehicle falls within 2 or more categories in schedule 2, the registration fee for the vehicle is the higher or highest of the fees that could apply to the vehicle.
- (2) To decide the number of trailers a prime mover or truck may tow—
  - (a) a dolly and a semitrailer, when used together, are taken to be 1 trailer; and
  - (b) a low loader and low loader dolly, when used together, are taken to be 1 trailer.
- (3) If a category 2 vehicle is registered according to a particular type in schedule 2, a person must not use the vehicle, or, whether or not the person is the vehicle's registered operator, permit another person to use the vehicle, as a vehicle of another type to which a higher registration fee applies.

Maximum penalty—80 penalty units.

*Example—*

If a vehicle is not registered to tow a trailer, the vehicle can not be used to tow a trailer unless its registration is changed and the relevant registration fee is paid.

- (4) For applying schedule 2, other than applying schedule 2 to a trailer—
  - (a) 2 axles with less than 1m between them are taken to be 1 axle; and
  - (b) 3 axles with not more than 2m between the first and third axles are taken to be 2 axles; and

[s 122]

---

- (c) 4 axles with not more than 3.2m between the first and fourth axles are taken to be 3 axles.
- (5) For applying subsection (4) in relation to a vehicle, the distance between axles is measured between the centres of the wheels—
  - (a) mounted on the axles; and
  - (b) parallel to the length of the vehicle.

## **Division 2                      Vehicles exempted from fees**

### **122      Exemption from payment of fee**

- (1) The registered operator of a vehicle or dealer plate may apply to the chief executive for an exemption from the payment of the following fees otherwise payable under this regulation—
  - (a) the registration fee payable for the registration of a vehicle or dealer plate if the registered operator is an association established solely for a charitable purpose within the meaning of the *Collections Act 1966* and the vehicle or dealer plate is used solely for that purpose;
  - (b) the registration fee payable for the registration of a vehicle if the registered operator is—
    - (i) a consulate; or
    - (ii) the head of a consulate; or
    - (iii) a career officer of a consulate; or
    - (iv) the head of an honorary consular mission;
  - (c) the fee payable for each of the following—
    - (i) the registration of a vehicle that is a motorised wheelchair used by a person with a disability affecting the person’s mobility;
    - (ii) an application for transfer of registration of a vehicle that is a motorised wheelchair used by a

- 
- person with a disability affecting the person's mobility;
- (d) the registration fee payable for the registration of a vehicle if the registered operator is—
    - (i) a designated overseas mission; or
    - (ii) the head of a designated overseas mission; or
    - (iii) an officer of a designated overseas mission;
  - (e) the traffic improvement fee for a category 1 vehicle under schedule 3 if—
    - (i) the vehicle is registered in the name of a prescribed service person who has been granted a concessional registration fee for the vehicle under section 123 for a vehicle mentioned in schedule 1, item 15; or
    - (ii) the chief executive may grant an exemption under paragraph (a), (b), (c)(i) or (d) for the vehicle.

*Note—*

See part 10, division 3A, subdivision 2 for requirements about the application.

- (2) Subject to section 109D(4) and (5) and subsection (3), the chief executive may grant the exemption.
- (3) An exemption for a fee mentioned in subsection (1)(b) or (d) may only be granted with the approval of the chief executive of the department within which the *Public Service Act 2008* is administered.
- (4) A person who is granted an exemption from the payment of the registration fee for a vehicle or dealer plate must give the chief executive notice—
  - (a) before using the vehicle or dealer plate for a purpose other than the purpose for which the exemption was granted; or
  - (b) within 14 days—

[s 122]

---

- (i) after a material change in the circumstances under which the exemption was granted; or
- (ii) of the sale or other transfer of the vehicle.

Maximum penalty—20 penalty units.

*Note—*

See part 10, division 3A, subdivision 3 for requirements about the notice.

- (5) On receipt of the notice, the chief executive may reassess the registration fee payable for the registration of the vehicle, without the exemption, for the term (the ***unexpired term***) from when the registered operator or vehicle stopped being eligible for the exemption to the end of the current registration term of the vehicle.
- (6) The chief executive may, by written notice, require the amount of the reassessed fee for the unexpired term to be paid by—
  - (a) if the notice mentioned in subsection (5) is given under subsection (4)(a) or (b)(i)—the person to whom the exemption was granted; or
  - (b) if the notice mentioned in subsection (5) is given under subsection (4)(b)(ii)—the person to whom the vehicle is sold or otherwise transferred.
- (7) The person to whom a notice given under subsection (6) is directed must, within 28 days after the chief executive gives the notice, pay the amount assessed.

Maximum penalty—60 penalty units.

- (8) In this section—

***designated overseas mission*** means a designated overseas mission under the *Overseas Missions (Privileges and Immunities) Act 1995* (Cwlth).

***officer***, of a designated overseas mission, means a person entrusted as an officer with the exercise of the functions of the designated overseas mission, but does not include a person

---

employed in the technical or administrative service of the designated overseas mission.

### **122A Exemption from payment of national heavy vehicle number plate fees**

- (1) This section applies if—
  - (a) a person applies to register a category 2 vehicle in the period starting on 1 July 2018 and ending on 30 June 2019; and
  - (b) the chief executive issues a national heavy vehicle number plate for the vehicle.
- (2) The person is exempt from paying the plate fee that would otherwise be payable for the issue of the number plate if—
  - (a) immediately before the application is made, the vehicle is registered under the *Interstate Road Transport Act 1985* (Cwlth); and
  - (b) the application is made by the person in whose name the vehicle is registered under the *Interstate Road Transport Act 1985* (Cwlth).

## **Division 3 Concessional registration fees for particular category 1 vehicles**

### **123 Concessional registration fees—category 1 vehicles**

- (1) The registered operator of a vehicle mentioned in schedule 1, part 2 may apply to the chief executive for a concessional registration fee for the vehicle.

*Note—*

See part 10, division 3A, subdivision 2 for requirements about the application.

- (2) Subject to section 109D(4) and (5) and subsection (3), the chief executive may grant the concessional registration fee.

[s 123]

---

- (3) The chief executive must not grant a concessional registration fee under subsection (1) for a vehicle mentioned in schedule 1, item 3, 6, 7 or 8 if the registered operator of the vehicle has already been granted a concessional registration fee under section 125 for another vehicle.
- (4) A person who is granted concessional registration for a vehicle must not use the vehicle, or permit the vehicle to be used—
  - (a) for a purpose other than the purpose for which the concession is granted; and
  - (b) other than under any conditions of the concessional registration.

Maximum penalty—20 penalty units.

- (5) A person who is granted concessional registration for a vehicle and who intends to use the vehicle for a purpose other than the purpose for which the concession was granted may advise the chief executive of the intention.
- (6) A person who is granted concessional registration for a vehicle must, within 14 days after a material change in the circumstances under which the concession was granted, give the chief executive notice of the change.

Maximum penalty—20 penalty units.

*Note—*

See part 10, division 3A, subdivision 3 for requirements about the notice.

- (7) A person who is granted concessional registration for a vehicle must, within 14 days after a sale or other transfer of the vehicle, give the chief executive notice of the sale or transfer.

Maximum penalty—20 penalty units.

*Note—*

See part 10, division 3A, subdivision 3 for requirements about the notice.

- (8) On receipt of advice under subsection (5), a notice under subsection (6) or (7), or prescribed concession information

---

about the person, the chief executive may reassess the registration fee payable for the vehicle's registration, without the concession, for the term (the *unexpired term*) from when the registered operator or vehicle stopped being eligible for the concession to the end of the vehicle's current registration term.

- (9) The chief executive may, by written notice, require the amount of the reassessed fee for the unexpired term to be paid by—
- (a) if the person's advice is given under subsection (5) or the person's notice is given under subsection (6)—the person to whom the concession was granted; or
  - (b) if the chief executive's notice is given because of prescribed concession information—the person to whom the concession was granted; or
  - (c) if the person's notice is given under subsection (7)—the person to whom the vehicle is sold or otherwise transferred.
- (10) The person to whom a notice given under subsection (9) is directed must, within 28 days after the chief executive gives the notice, pay the amount assessed.

Maximum penalty for subsection (10)—20 penalty units.

## **Division 4                      Concessional registration fees for category 2 vehicles**

### **124      Concessional registration fees—primary production vehicles**

- (1) A primary producer may apply to the chief executive for a concessional registration fee under schedule 2, part 3 for the registration of a primary production vehicle.

*Note—*

See part 10, division 3A, subdivision 2 for requirements about the application.

[s 124]

---

- (2) Subject to section 109D(4) and (5), the chief executive may grant the concessional registration fee.
- (3) A primary producer who is granted concessional registration for a primary production vehicle must not use the vehicle, or permit the vehicle to be used, for a purpose other than—
  - (a) for carrying on the producer’s business as a primary producer; or
  - (b) as permitted under section 100G.

Maximum penalty—60 penalty units.

- (4) A primary producer who is granted concessional registration for a primary production vehicle must, within 14 days of a sale or other transfer of the vehicle, give the chief executive notice of the sale or other transfer.

Maximum penalty—60 penalty units.

*Note—*

See part 10, division 3A, subdivision 3 for requirements about the notice.

- (5) A primary producer who is granted concessional registration for a primary production vehicle and who intends to use the vehicle for a purpose other than for carrying on the producer’s business as a primary producer or as permitted under section 100G may advise the chief executive of the intention.
- (6) On receipt of the notice or advice, the chief executive may reassess the registration fee payable for the vehicle’s registration, without the concession, for the term (the *unexpired term*) from when the primary producer stopped being eligible for the concession, or the end of the day the chief executive received the notice or advice, to the end of the vehicle’s current registration term.
- (7) The chief executive may, by written notice, require any amount by which the reassessed fee is more than the fee already paid for the unexpired term to be paid by—
  - (a) the primary producer who gave the advice; or



- (b) the person to whom the vehicle mentioned in the notice under subsection (4) is sold or otherwise transferred.
- (8) The person to whom a notice given under subsection (7) is directed must, within 28 days after the chief executive gives the notice, pay the amount assessed.

Maximum penalty for subsection (8)—60 penalty units.

## **125 Concessional registration fee for motorised caravan for card holders and prescribed service persons**

- (1) A card holder or prescribed service person may apply to the chief executive for a concessional registration fee under schedule 2, item 31, 32 or 33 for the registration of a motorised caravan registered in the name of the card holder or prescribed service person.

*Note—*

See part 10, division 3A, subdivision 2 for requirements about the application.

- (2) Subject to section 109D(4) and (5) and subsection (3), the chief executive may grant the concessional registration fee.
- (3) The chief executive must not grant a concessional registration fee under subsection (1) if the registered operator of the vehicle has already been granted a concessional registration fee under section 123 for a vehicle mentioned in schedule 1, item 3, 6, 7 or 8.
- (4) A person who is granted a concessional registration, as a card holder or prescribed service person, for a motorised caravan must give the chief executive notice—
  - (a) of ceasing to be a card holder or prescribed service person—within 14 days after the cessation; or
  - (b) of the sale or other transfer of the caravan—within 14 days after the sale or other transfer.

Maximum penalty—20 penalty units.

*Note—*

See part 10, division 3A, subdivision 3 for requirements about the notice.

- (5) On receipt of the notice, or prescribed concession information about a person mentioned in subsection (4), the chief executive may reassess the registration fee payable for the caravan's registration, without the concession, for the term (the *unexpired term*) from when the person stopped being eligible for the concession to the end of the caravan's current registration term.
- (6) The chief executive may, by written notice, require any amount by which the reassessed fee is more than the fee already paid for the unexpired term to be paid by—
  - (a) if the person's notice is given under subsection (4)(a)—that person; or
  - (b) if the person's notice is given under subsection (4)(b)—the person to whom the caravan is sold or otherwise transferred; or
  - (c) if the prescribed concession information is about a person mentioned in subsection (4)—that person.
- (7) The person to whom a notice given under subsection (6) is directed must, within 28 days after the chief executive gives the notice, pay the amount assessed.

Maximum penalty for subsection (7)—20 penalty units.

## **126 Concessional registration fees for other vehicles**

- (1) A person may apply to the chief executive for a concessional registration fee under schedule 2, item 28 or 29 for the registration of a vehicle.

*Note—*

See part 10, division 3A, subdivision 2 for requirements about the application.

- (2) Subject to section 109D(4) and (5), the chief executive may grant the concessional registration fee.

- 
- (3) A person who is granted concessional registration for a vehicle must not use the vehicle, or permit the vehicle to be used—
- (a) for a purpose other than the purpose for which the concession is granted; and
  - (b) other than under any conditions of the concessional registration.

Maximum penalty—60 penalty units.

- (4) A person who is granted concessional registration for a vehicle must, within 14 days of a sale or other transfer of the vehicle, give the chief executive notice of the sale or other transfer.

Maximum penalty—60 penalty units.

*Note—*

See part 10, division 3A, subdivision 3 for requirements about the notice.

- (5) A person who is granted concessional registration for a vehicle and who intends to use the vehicle for a purpose other than the purpose for which the concession was granted may advise the chief executive of the intention.
- (6) On receipt of the notice or advice, the chief executive may reassess the registration fee payable for the vehicle's registration, without the concession, for the term (the ***unexpired term***) from when the person stopped being eligible for the concession, or the end of the day the chief executive received the notice or advice, to the end of the vehicle's current registration term.
- (7) The chief executive may, by written notice, require any amount by which the reassessed fee is more than the fee already paid for the unexpired term to be paid by—
- (a) the person who gave the advice; or
  - (b) the person to whom the vehicle mentioned in the notice under subsection (4) is sold or otherwise transferred.

- (8) The person to whom a notice given under subsection (7) is directed must, within 28 days after the chief executive gives the notice, pay the amount assessed.

Maximum penalty for subsection (8)—60 penalty units.

## **Part 12                      Other offence provisions and power to recover number plates in particular circumstances**

### **127      Offences involving registration certificates etc.**

- (1) A person must not, unless the person has a reasonable excuse—
- (a) make, sell or have in the person's possession anything that purports to be, but is not, a registration certificate, number plate or permit; or
  - (b) alter or deface a registration certificate, number plate or permit.

Maximum penalty—40 penalty units.

- (2) A person must not, unless the person has a reasonable excuse, use, or permit to be used, on a road a vehicle if—
- (a) a registration certificate, number plate or permit for the vehicle has been unlawfully altered; or
  - (b) a registration certificate, number plate or permit for the vehicle has been defaced; or
  - (c) a reflectorised number plate for the vehicle has been repainted in any way, for example, to repair stone chips or other damage; or
  - (d) any writing, mark, or colour on a registration certificate, number plate or permit for the vehicle is not clearly legible; or

- (e) a number plate or permit attached to the vehicle was issued for another vehicle; or
- (f) a number plate attached to the vehicle has been recorded in the register as having been cancelled, lost, stolen, destroyed or damaged; or
- (g) a number plate required under this regulation to be attached to the vehicle is not attached to the vehicle; or
- (h) a number plate is attached to the vehicle, but—
  - (i) not in the way required under this regulation; or
  - (ii) under section 39, the number plate must not be attached to the vehicle; or
- (i) a permit required under section 60(5)(a) to be carried by the driver of the vehicle is not being carried by the driver of the vehicle; or
- (j) a permit required under section 60(5)(b) to be carried in the vehicle is not being carried in the vehicle.
- (k) a permit required under this regulation to be attached to the vehicle—
  - (i) is not attached to the vehicle; or
  - (ii) is attached to the vehicle, but not in the way required under this regulation.

Maximum penalty—16 penalty units.

- (3) In this section, a reference to a registration certificate, number plate or permit is a reference to a registration certificate, number plate or permit issued—
  - (a) by the chief executive under this regulation; or
  - (b) under a corresponding law to this regulation; or
  - (c) under a law of a foreign country about the registration of vehicles.

## 128 Requirement to remove unlawful registration item

- (1) An authorised officer may require a person in charge of a vehicle to take a registration item from the vehicle, and to deliver it to the authorised officer, if the authorised officer believes on reasonable grounds that—
  - (a) under this regulation, the use of the vehicle on a road is prohibited; or
  - (b) the registration item was not lawfully issued for the vehicle; or
  - (c) the registration item is recorded in the register as having been cancelled, lost, stolen, destroyed or damaged; or
  - (d) the registration item is a number plate required to be returned to the chief executive under section 102.

*Note—*

Section 102(5) provides for what the chief executive must do if a number plate is delivered to an authorised officer under paragraph (d).

- (2) If a requirement is made under subsection (1)(a), on the basis that section 127(2)(h)(ii) applies, or under subsection (1)(b), (c) or (d), the authorised officer must advise the person that if the person does not comply with the requirement at the time it is made the officer may, under section 128A, remove and recover the number plates attached to the vehicle.
- (3) The person must not contravene the requirement unless the person has a reasonable excuse.

Maximum penalty—16 penalty units.

- (4) In this section—

**registration item** means—

- (a) a registration certificate, number plate, permit or similar item; or
- (b) an item purporting to be an item mentioned in paragraph (a).

---

**128A Authorised officer may remove and recover number plates in particular circumstances**

- (1) This section applies if an authorised officer—
  - (a) makes a requirement under—
    - (i) section 128(1)(a), on the basis that section 127(2)(h)(ii) applies; or
    - (ii) section 128(1)(b), (c) or (d); and
  - (b) complies with subsection 128(2).
- (2) If the person contravenes the requirement the authorised officer may remove and recover the number plates attached to the vehicle.

**Part 13 Repeal and transitional provisions**

**Division 1 Repeal**

**129 Repeal of regulation**

The Transport Operations (Road Use Management—Vehicle Registration) Regulation 1999, SL No. 225 is repealed.

**Division 2 Transitional provision for repeal**

**130 References to repealed regulation**

In an Act or other document, a reference to the *Transport Operations (Road Use Management—Vehicle Registration) Regulation 1999* may, if the context permits, be taken to be a reference to this regulation.

## **Division 3**                      **Transitional provisions for Transport Operations (Road Use Management—Vehicle Registration) Amendment Regulation (No. 2) 2014**

### **131**      **Definitions for div 3**

In this division—

*former*, for a provision, means the provision as in force from time to time before it was amended by the *Transport Operations (Road Use Management—Vehicle Registration) Amendment Regulation (No. 2) 2014*.

*stated vehicle* means a category 1 vehicle, conditionally registered vehicle or special purpose vehicle.

### **132**      **No obligation to attach registration labels for stated vehicles**

- (1) This section applies to the registered operator of a stated vehicle if the registered operator receives a registration label for the vehicle after 8 September 2014.
- (2) Despite former section 41, the registered operator is not required to attach the registration label to the vehicle.

### **133**      **No obligation to issue registration certificate or label for stated vehicles**

- (1) This section applies if the renewal of the registration of a stated vehicle becomes effective on or after 1 October 2014 and either—
  - (a) the chief executive renewed the registration before 1 October 2014; or
  - (b) the registration in effect before the renewal expired before 1 October 2014.



- 
- (2) Despite former section 47(2), the chief executive is not required to issue the following to the registered operator of the vehicle—
- (a) a registration label;
  - (b) if subsection (1)(a) applies—an updated registration certificate.

### **134 Cancellation notices under former ss 57 and 58**

- (1) Subsection (2) applies in relation to either of the following notices given by the chief executive for a stated vehicle after 15 September 2014—
- (a) a notice mentioned in section 57(2);
  - (b) a notice mentioned in section 58(3).
- (2) Despite former sections 57 and 58—
- (a) the chief executive is not required to include in the notice a requirement that the registration label for the vehicle must be returned to the chief executive; and
  - (b) the person to whom the notice is directed is not required to return the registration label for the vehicle to the chief executive.
- (3) Subsection (4) applies in relation to a notice mentioned in section 58(7) for a dealer plate given by the chief executive after 15 September 2014.
- (4) Despite former section 58—
- (a) the chief executive is not required to include in the notice a requirement that the registration label for the dealer plate must be returned to the chief executive; and
  - (b) the person to whom the notice is directed is not required to return the registration label for the dealer plate to the chief executive.

[s 135]

---

**135 Cancellation of dealer plates under former s 65**

- (1) This section applies in relation to a dealer plate if a relevant event mentioned in section 65(2) happens after 15 September 2014 in relation to a person in whose name the dealer plate is registered.
- (2) Despite former section 65(3), the person is not required to return the registration label for the dealer plate to the chief executive.

**136 Replacement registration labels for stated vehicles under former s 101**

- (1) This section applies if a current registration label for a stated vehicle is damaged, destroyed, lost or stolen after 15 September 2014 and before 1 October 2014.
- (2) Former section 101, other than subsection (4)(a), does not apply in relation to the registration label.
- (3) Without limiting subsection (2)—
  - (a) the registered operator of the stated vehicle is not required to apply under former section 101(2) for a replacement of the registration label; and
  - (b) the chief executive is not required to issue a replacement registration label.

**Division 4 Transitional provision for Transport and Other Legislation (Personalised Transport Reform) Amendment Regulation (No. 2) 2017**

**137 Notifying change of purpose of use for vehicle used for booked hire service**

- (1) This section applies if the purpose of use for a vehicle, other than a limousine or taxi, is changed to be or include providing

---

a booked hire service under the *Transport Operations (Passenger Transport) Act 1994*.

- (2) The registered operator of the vehicle does not commit an offence for a contravention of section 20(1)(d) in relation to the change.
- (3) Subsection (2) applies even if the contravention happened before the commencement.
- (4) However, this section applies to a change of a kind mentioned in subsection (1) only if the change happens before 15 January 2018.

## **Division 5                      Transitional provisions for Transport Operations (Road Use Management—Vehicle Registration) (Heavy Vehicles) Amendment Regulation 2018**

### **138      Definition for division**

In this division—

*former*, for a provision of this regulation, means as in force from time to time before its repeal or amendment by the *Transport Operations (Road Use Management—Vehicle Registration) (Heavy Vehicles) Amendment Regulation 2018*.

### **139      No obligation to attach registration labels for category 2 vehicles**

- (1) This section applies to the registered operator of a category 2 vehicle if the registered operator receives a registration label for the vehicle after 16 June 2018.
- (2) Despite former sections 40 and 41, the registered operator is not required to attach the registration label to the vehicle.

**140 No obligation to issue registration certificate or label for category 2 vehicles**

Despite former section 47(2), the chief executive is not required to issue the following to the registered operator of a category 2 vehicle from 1 July 2018—

- (a) a registration label;
- (b) an updated registration certificate.

**141 Cancellation notices under former ss 57 and 58**

(1) Subsection (2) applies in relation to either of the following notices given by the chief executive for a category 2 vehicle after 16 June 2018—

- (a) a notice mentioned in section 57(2);
- (b) a notice mentioned in section 58(3).

(2) Despite former sections 57 and 58—

- (a) the chief executive is not required to include in the notice a requirement that the registration label for the vehicle must be returned to the chief executive; and
- (b) the person to whom the notice is directed is not required to return the registration label for the vehicle to the chief executive.

**142 Replacement registration labels for category 2 vehicles under former s 101**

(1) This section applies if a current registration label for a category 2 vehicle is damaged, destroyed, lost or stolen after 16 June 2018.

(2) Former section 101 does not apply in relation to the registration label.

(3) Without limiting subsection (2)—

- (a) the registered operator of the category 2 vehicle is not required to apply under former section 101(2) for a replacement of the registration label; and

- 
- (b) the chief executive is not required to issue a replacement registration label.

## **Division 6                      Transitional provision for Transport Operations (Road Use Management—Vehicle Registration) and Other Legislation Amendment Regulation 2019**

### **143      Fees**

- (1) The amendment of schedule 3, part 3, made by the amending regulation, applies in relation to—
- (a) applications made after the commencement for the registration, or renewal of the registration, of a vehicle; and
  - (b) payments made after the commencement for the renewal of the registration of a vehicle after the expiry date.
- (2) The amendment of section 120, made by the amending regulation, applies in relation to applications made after the commencement for the registration, or renewal of the registration, of a vehicle.
- (3) In this section—

*amending regulation* means the *Transport Operations (Road Use Management—Vehicle Registration) and Other Legislation Amendment Regulation 2019*.

## Schedule 1 Category 1 vehicle registration fees for 1 year

section 120(1)

### Part 1 Registration fees

	Fee for prescribed private use vehicles		Fee for vehicles other than prescribed private use vehicles	
	2019–2020	2020–2021	2019–2020	2020–2021
	\$	\$	\$	\$
1 Motor vehicle with a GVM of not more than 4t—				
(a) 1, 2 or 3 cylinders, electric or steam	258.40	263.05	280.35	285.40
(b) 4 cylinders or 2 rotors	328.60	334.50	356.65	363.05
(c) 5 or 6 cylinders or 3 rotors	520.30	529.65	564.55	574.70
(d) 7 or 8 cylinders	728.65	741.75	790.60	804.85
(e) 9 to 12 cylinders	854.50	869.90	927.15	943.85
2 Motor vehicle, other than a motorised caravan or bus, with a GVM more than 4t but not more than 4.5t	816.70	831.40	886.30	902.25
3 Motorised caravan with a GVM more than 4t but not more than 4.5t	593.65	604.35	644.20	655.80

	Fee for prescribed private use vehicles		Fee for vehicles other than prescribed private use vehicles	
	2019–20 20	2020–20 21	2019–20 20	2020–20 21
	\$	\$	\$	\$
4 Bus with a GVM more than 4t but not more than 4.5t	814.00	828.65	883.25	899.15
5 Mobile machinery—				
(a) GVM not more than 1t			201.05	204.65
(b) GVM more than 1t but not more than 2t			275.55	280.50
(c) GVM more than 2t but not more than 3t			350.25	356.55
(d) GVM more than 3t but not more than 4t			424.75	432.40
(e) GVM more than 4t but not more than 4.5t			430.65	438.40
6 Motorbike			124.10	126.35
7 Trailer—				
(a) ATM not more than 1.02t			112.40	114.40
(b) ATM more than 1.02t but not more than 4.5t			214.00	217.85

Note—

Under schedule 8, definition *caravan*, a caravan is a type of trailer.

## Part 2 Concessional registration fees

	Fee for prescribed private use vehicles		Fee for vehicles other than prescribed private use vehicles	
	2019–2020	2020–2021	2019–2020	2020–2021
	\$	\$	\$	\$
8 Ambulance vehicle			100.50	102.30
9 Vehicle, with distance and road use limits imposed by the chief executive, owned by a primary producer and used only in the owner’s business as a primary producer—				
(a) motor vehicle with a GCM or GVM not more than 4t			106.15	108.05
(b) motor vehicle with a GCM or GVM more than 4t but not more than 4.5t			155.20	158.00
(c) trailer with an ATM not more than 4.5t			106.15	108.05
10 In accordance with schedule 4, items 1, 3, 4, 6, 7 and 8, one motor vehicle, other than a conditionally registered vehicle or mobile machinery, registered in the name of the holder of a seniors card, the greater of the following—				
(a) 50% of the part 1 fee				
(b)	92.60	94.25	100.50	102.30



	Fee for prescribed private use vehicles		Fee for vehicles other than prescribed private use vehicles	
	2019–20 20	2020–20 21	2019–20 20	2020–20 21
	\$	\$	\$	\$
11 Motor vehicle mentioned in schedule 5 with a GCM or GVM not more than 4t, other than a conditionally registered vehicle	92.60	94.25	100.50	102.30
12 Motor vehicle mentioned in schedule 5 with a GCM or GVM more than 4t but not more than 4.5t, other than a conditionally registered vehicle, the greater of the following—				
(a) 25% of the part 1 fee				
(b)	92.60	94.25	100.50	102.30
13 In accordance with schedule 4, items 2, 3, 4, 6, 7 and 8, one motor vehicle, other than a conditionally registered vehicle or mobile machinery, registered in the name of the holder of a pensioner concession card who first held a pensioner concession card before 1 July 1994 and has, during the period since then, held a pensioner concession card—				
(a) with a GCM or GVM not more than 4t	92.60	94.25	100.50	102.30
(b) with a GVM more than 4t but not more than 4.5t, the greater of the following—				

Schedule 1

	Fee for prescribed private use vehicles		Fee for vehicles other than prescribed private use vehicles	
	2019–2020	2020–2021	2019–2020	2020–2021
	\$	\$	\$	\$
(i) 25% of the part 1 fee				
(ii)	92.60	94.25	100.50	102.30
14 In accordance with schedule 4, items 2, 3, 4, 6, 7 and 8, one motor vehicle, other than a conditionally registered vehicle or mobile machinery, registered in the name of the holder of a pensioner concession card, with a GCM or GVM not more than 4.5t, unless item 13 applies, the greater of the following—				
(a) 50% of the part 1 fee				
(b)	92.60	94.25	100.50	102.30
15 In accordance with schedule 4, items 1, 3, 4, 6, 7 and 8, one motor vehicle, other than a conditionally registered vehicle or mobile machinery, registered in the name of a prescribed service person, with a GCM or GVM not more than 4.5t	92.60	94.25	100.50	102.30
16 Special interest vehicle—				
(a) for a motorbike			34.95	35.60
(b) for a special interest vehicle other than a motorbike	92.60	94.25	100.50	102.30

## Schedule 2 Category 2 vehicle registration fees for 1 year

section 120(2) and (3)

### Part 1 Registration fees for financial year starting on 1 July 2019 or 1 July 2020—nationally regulated fees

#### Vehicles

Vehicle type	2 axles	3 axles	4 axles	5 or more axles
	\$	\$	\$	\$
1 Trucks—				
(a) truck (type 1)—				
(i) road use component	412.00	720.00	720.00	720.00
(ii) regulatory component	195.00	230.00	245.00	245.00
(b) truck (type 2)—				
(i) road use component	720.00	817.00	817.00	817.00
(ii) regulatory component	255.00	325.00	346.00	346.00
(c) short combination truck—				
(i) road use component	720.00	817.00	1,695.00	1,695.00

Schedule 2

**Vehicles**

<b>Vehicle type</b>	<b>2 axles</b>	<b>3 axles</b>	<b>4 axles</b>	<b>5 or more axles</b>
	\$	\$	\$	\$
(ii) regulatory component	285.00	362.00	347.00	347.00
(d) medium combination truck—				
(i) road use component	8,906.00	8,906.00	9,619.00	9,619.00
(ii) regulatory component	648.00	648.00	701.00	701.00
(e) long combination truck—				
(i) road use component	12,312.00	12,312.00	12,312.00	12,312.00
(ii) regulatory component	896.00	896.00	896.00	896.00
2 Prime movers—				
(a) short combination prime mover—				
(i) road use component	720.00	4,108.00	4,416.00	4,416.00
(ii) regulatory component	404.00	404.00	404.00	404.00
(b) multi-combination prime mover—				
(i) road use component	10,421.00	10,421.00	11,463.00	11,463.00
(ii) regulatory component	912.00	912.00	1,003.00	1,003.00

**Trailers**

Trailer type	single axle or single axle group	tandem axle group	tri-axle group	quad-axle group	multi- axle group, for each axle
	\$	\$	\$	\$	\$
3 Pig trailer—					
(a) road use component	612.00	1,224.00	1,836.00	2,448.00	612.00
(b) regulatory component	55.00	56.00	54.00	56.00	14.00
4 Dog trailer—					
(a) road use component	612.00	1,224.00	1,836.00	2,448.00	612.00
(b) regulatory component	55.00	56.00	54.00	56.00	14.00
5 Semitrailer—					
(a) road use component	612.00	1,556.00	1,659.00	1,660.00	415.00
(b) regulatory component	55.00	56.00	54.00	56.00	14.00
6 B-double lead trailer, B-triple lead trailer or B-triple middle trailer—					
(a) road use component	612.00	1,556.00	1,659.00	1,660.00	415.00
(b) regulatory component	55.00	56.00	54.00	56.00	14.00
7 Converter dolly or low loader dolly—					
(a) road use component	nil	nil	nil	nil	nil

Schedule 2

**Trailers**

Trailer type	single axle or single axle group	tandem axle group	tri-axle group	quad-axle group	multi- axle group, for each axle
	\$	\$	\$	\$	\$
(b) regulatory component	55.00	56.00	54.00	56.00	14.00

**Buses**

Bus type	2 axles	3 axles	4 or more axles
	\$	\$	\$
8 Bus (type 1)—			
(a) road use component	309.00	nil	nil
(b) regulatory component	204.00	nil	nil
9 Bus (type 2)—			
(a) road use component	309.00	2,260.00	2,260.00
(b) regulatory component	334.00	414.00	414.00
10 Articulated bus—			
(a) road use component	nil	309.00	309.00
(b) regulatory component	nil	331.00	331.00

**Special purpose vehicles**

			\$
11 Special purpose vehicle (type o)—			
(a) road use component	375.00+375.00 for each axle in excess of 2 axles		
(b) regulatory component			202.00



Schedule 2

---

caravan or vehicle that may be conditionally registered, is as follows—

- (a) for a truck with 2 or 3 axles—50%;
- (b) for a truck with 4 or more axles—25%;
- (c) for a short combination prime mover, or a short combination truck, medium combination truck or long combination truck, with 2 axles—50%;
- (d) for a multi-combination prime mover with 2 axles—25%;
- (e) for a short combination prime mover or multi-combination prime mover, or a short combination truck, medium combination truck or long combination truck, with 3 or more axles—25%;
- (f) for a trailer with 1 axle—50%;
- (g) for a trailer with 2 axles—35%;
- (h) for a trailer with 3 or more axles—30%;
- (i) for a special purpose vehicle—25%;
- (j) for a caravan, mobile library, mobile workshop, mobile laboratory or mobile billboard—35%;
- (k) for a bus—50%.

16 The concessional registration fee for a special interest vehicle is—

- (a) for a term starting on or after 1 July 2019—\$100.50; or
- (b) for a term starting on or after 1 July 2020—\$102.30.

17 The concessional registration fee for a vehicle, with distance and road use limits imposed by the chief executive, owned by a primary producer and used only in the owner's business as a primary producer is—

- (a) for a motor vehicle—
  - (i) for a term starting on or after 1 July 2019—\$65.05; or



- 
- (ii) for a term starting on or after 1 July 2020—\$66.20; or
  - (b) for a trailer—
    - (i) for a term starting on or after 1 July 2019—\$155.20; or
    - (ii) for a term starting on or after 1 July 2020—\$158.00.
  - 18 In accordance with schedule 4, items 1, 3, 5, 6, 9 and 10, the percentage of the registration fee payable under a concessional registration for a motorised caravan registered in the name of the holder of a seniors card is 50%.
  - 19 In accordance with schedule 4, items 2, 3, 5, 6, 9 and 10, the percentage of the registration fee payable under a concessional registration for a motorised caravan registered in the name of a card holder who holds a pensioner concession card is—
    - (a) if the card holder first held a pensioner concession card before 1 July 1994 and has during the period since then held a pensioner concession card—25%; or
    - (b) otherwise—50%.
  - 20 In accordance with schedule 4, items 1, 3, 5, 6, 9 and 10, the percentage of the registration fee payable under a concessional registration for a motorised caravan registered in the name of a prescribed service person is 25%.

## Schedule 3 Other fees

section 120(4)

### Part 1 Nationally regulated plate fees

	\$
1A National heavy vehicle number plates	25.90
1B Replacement national heavy vehicle number plates, unless item 1D applies	25.90
1C Accessory plate to be attached to category 2 vehicle with national heavy vehicle number plates	25.90
1D Replacement of the following—	
(a) an accessory plate;	25.90 plus manufacturing costs
(b) a national heavy vehicle number plate or pair of plates with the same number and design as the replaced plate or plates	25.90 plus manufacturing costs

### Part 2 Other plate fees

	\$
1 Limousine number plates	47.35
2 Fire and emergency appliance number plates	53.35

	\$
3 Accessory plate, other than an accessory plate to be attached to a category 2 vehicle with national heavy vehicle number plates	31.45
4 Another number plate	31.45
5 Replacement of any of the following, unless item 6 applies—	
(a) dealer plate	116.75
(b) limousine number plates	47.35
(c) another number plate	31.45
6 Replacement plate or pair of plates with the same number and design as the replaced plate or plates	31.45
	plus manufacturing costs

### **Part 3 Fees relating to vehicle registration**

	2019–2020	2020–2021
	\$	\$
7 Surcharge for processing an application for registration, or for renewal of registration that is payable under section 44, for a term of 6 months—		
(a) for a category 1 vehicle (other than concessional registration or conditional registration)	8.65	8.80
(b) for a category 2 vehicle (other than conditional registration)	38.50	39.20

## Schedule 3

	2019–2020	2020–2021
	\$	\$
(c) for concessional registration of a category 1 vehicle	5.25	5.35
(d) for a conditional registration of a vehicle	8.65	8.80
8 Surcharge for processing an application for registration, or for renewal of registration that is payable under section 44, for a term of 3 months—		
(a) for a category 1 vehicle (other than concessional registration or conditional registration)	4.30	4.40
(b) for a category 2 vehicle (other than conditional registration)	19.25	19.60
(c) for concessional registration of a category 1 vehicle	2.60	2.65
(d) for conditional registration of a vehicle	4.30	4.40
9 Surcharge for processing an application for registration, or for renewal of registration that is payable under section 44, for a term of 1 month—		
(a) for a category 1 vehicle (other than concessional registration or conditional registration)	1.45	1.50
(b) for a category 2 vehicle (other than conditional registration)	6.40	6.50
(c) for concessional registration of a category 1 vehicle	1.00	1.00
(d) for conditional registration of a vehicle	1.45	1.50
10 Surcharge for processing an application for renewal of registration, payable under section 44, for a term of 1 year—		

	2019–2020	2020–2021
	\$	\$
(a) for a category 1 vehicle (other than concessional registration or conditional registration)	8.65	8.80
(b) for a category 2 vehicle (other than conditional registration)	38.50	39.20
(c) for concessional registration of a category 1 vehicle	5.25	5.35
(d) for conditional registration of a vehicle	8.65	8.80
11 Traffic improvement fee for a category 1 vehicle that—		
(a) is a prescribed private use vehicle	57.30	58.35
(b) is not a prescribed private use vehicle	62.25	63.35
12 Registration administration fee for a category 2 vehicle other than a trailer	75.25	76.60
13 Application fee for registration of dealer plate (s 62(4)(a))	600.55	611.35
14 Registration administration fee for conditionally registered vehicle—		
(a) limited access registration	49.05	49.95
(b) zone access registration	49.05	49.95
(c) unrestricted access registration	107.40	109.35
15 Administrative fee payable on payment for renewal of registration after the expiry date for a term other than a term of 1 month—		
(a) renewal of registration of a dealer plate or category 1 vehicle or category 2 vehicle other than—		
• a trailer that is a category 1 vehicle		

Schedule 3

	2019–2020	2020–2021
	\$	\$
<ul style="list-style-type: none"> <li>• a special interest vehicle that is subject to concessional registration</li> <li>• a vehicle that may be conditionally registered</li> <li>• a vehicle for which an exemption from the payment of the registration fee payable for the renewal has been granted under section 122(1)(a) or (b)</li> </ul>		
• drawn plant	65.30	66.50
(b) otherwise	16.20	16.50
16 Administrative fee payable on payment for renewal of registration after the expiry date for a term of 1 month—		
(a) renewal of registration of a dealer plate or category 1 vehicle or category 2 vehicle other than—		
<ul style="list-style-type: none"> <li>• a trailer that is a category 1 vehicle</li> <li>• a special interest vehicle that is subject to concessional registration</li> <li>• a vehicle that may be conditionally registered</li> <li>• a vehicle for which an exemption from the payment of the registration fee payable for the renewal has been granted under section 122(1)(a) or (b)</li> </ul>		
• drawn plant	21.80	22.20
(b) otherwise	5.40	5.50

## Part 4 Miscellaneous fees

	\$
17 Notifying chief executive of the transfer of a personalised number plate under section 34(2)	105.95
18 Application for—	
(a) transfer of registration under section 48	29.20
(b) unregistered vehicle permit under section 60, for each day	34.90
19 Extract from the register of information given about a vehicle under section 115(1) or vehicle-related information about a vehicle given under section 117(2)—	
(a) if the vehicle’s registration number, VIN, chassis number or engine number is supplied, for each vehicle	18.70
(b) if the name and address of the person in whose name a vehicle is registered are supplied but not the vehicle’s registration number, for each list of vehicle registration numbers supplied	11.20
(c) for each extract from archival records, for each vehicle	29.85
(d) for each extract certified by the chief executive, for each vehicle	29.85
20 Extract from the register of information about a vehicle obtained under section 115(3)—	
(a) if the vehicle’s registration number is supplied, for each vehicle	18.70
(b) if the name and address of the person in whose name a vehicle is registered are supplied, but not the vehicle’s registration number, for each list of vehicle registration numbers supplied	11.20

Schedule 3

---

	\$
(c) if information about the vehicle is supplied by electronic or disk file, for each vehicle	11.20
(d) for each extract certified by the chief executive, for each vehicle	29.85
21 Customising a number plate under section 36	53.00
22 Administration fee for making a refund under section 56	19.10



## **Schedule 4 Provisions that particular items of schedule 1, part 2 and schedule 2, part 3 are subject to**

schedule 1, items 10, 13, 14 and 15 and schedule 2, items 31, 32 and 33

- 1 Schedule 1, item 10 or 15 or schedule 2, item 31 or 33 applies if—
  - (a) the vehicle mentioned in the relevant item is used mainly by the person who is granted concessional registration for the vehicle; and
  - (b) the vehicle’s purpose of use is recorded as private purposes in the register.
- 2 Schedule 1, item 13 or 14 or schedule 2, item 32 applies if—
  - (a) the vehicle mentioned in the relevant item is used mainly by the person who is granted concessional registration for the vehicle; and
  - (b) the vehicle’s purpose of use is recorded as private purposes in the register; and
  - (c) the pensioner concession card mentioned in schedule 1, item 13 or 14 or schedule 2, item 32 was issued in Queensland; and
  - (d) for a card holder who is receiving a parenting payment that is a pension PP (single) under the *Social Security Act 1991* (Cwlth)—the card holder is the sole registered operator of the vehicle; and
  - (e) for a card holder who is receiving an income support supplement under the *Veterans’ Entitlements Act 1986* (Cwlth)—the card holder’s rate of income support supplement has not been reduced by—
    - (i) the ordinary/adjusted income test under schedule 6, part 2, module E of that Act; or

Schedule 4

---

- (ii) the assets test under schedule 6, part 2, module F of that Act.
- 3 However, schedule 1, item 10, 13, 14 or 15 or schedule 2, item 31, 32 or 33 does not apply if any spouse of the person in whose name the vehicle mentioned in the relevant item is registered—
  - (a) is a card holder or prescribed service person; and
  - (b) has been granted a concessional registration fee, under section 123 for a vehicle mentioned in schedule 1, item 10, 13, 14 or 15 or under section 125, for the current registration term for the registration of another vehicle.
- 4 Also, if there are 2 registered operators of a vehicle mentioned in schedule 1, item 10, 13, 14 or 15 (***relevant schedule 1, part 2 item***), each registered operator must be eligible for a concessional registration fee under a relevant schedule 1, part 2 item.
- 5 Also, if there are 2 registered operators of a vehicle mentioned in schedule 2, item 31, 32 or 33 (***relevant schedule 2, part 3 item***), each registered operator must be eligible for a concessional registration fee under a relevant schedule 2, part 3 item.
- 6 However, item 4 or 5 does not apply if the registered operators of the vehicle are spouses of each other.
- 7 Item 8 applies if—
  - (a) there are 2 registered operators of a vehicle mentioned in a relevant schedule 1, part 2 item; and
  - (b) each of the registered operators is eligible under a relevant schedule 1, part 2 item for a concessional registration fee for the vehicle that differs from the concessional registration fee for the vehicle that the other registered operator is eligible for under another relevant schedule 1, part 2 item.
- 8 Despite section 123(1), the concessional registration fee for the registration of the vehicle is—
  - (a) if each of the registered operators is the spouse of the other registered operator—the lowest of the

- concessional registration fees for the vehicle that the registered operators are eligible for under a relevant schedule 1, part 2 item; or
- (b) otherwise—the highest of the concessional registration fees for the vehicle that the registered operators are eligible for under a relevant schedule 1, part 2 item.
- 9 Item 10 applies if—
- (a) there are 2 registered operators of a vehicle mentioned in a relevant schedule 2, part 3 item; and
- (b) each of the registered operators is eligible under a relevant schedule 2, part 3 item for a concessional registration fee for the vehicle that differs from the concessional registration fee for the vehicle that the other registered operator is eligible for under another relevant schedule 2, part 3 item.
- 10 Despite section 125(1), the concessional registration fee for the registration of the vehicle is—
- (a) if each of the registered operators is the spouse of the other registered operator—the lowest of the concessional registration fees for the vehicle that the registered operators are eligible for under a relevant schedule 2, part 3 item; or
- (b) otherwise—the highest of the concessional registration fees for the vehicle that the registered operators are eligible for under a relevant schedule 2, part 3 item.

## **Schedule 5      Vehicles for particular concessional registration fees**

schedule 1, items 11 and 12 and schedule 2, item 28

### **2      Local government vehicle**

A vehicle whose registered operator is a local government.

### **3      Community service organisation vehicle**

A vehicle, whose registered operator is a community service organisation, used on a road solely to give help to persons in distress.

### **4      Vehicle used only in particular areas**

A vehicle used on a road only in 1 or more of the following areas—

- the following local government areas—
  - Aurukun
  - Doomadgee
  - Kowanyama
  - Pormpuraaw
  - Yarrabah
- a coastal island that is not joined to the mainland by a bridge
- the area north of the Archer River from the western to the eastern end of the river
- the area north of a straight line from the eastern end of the Archer River to Friendly Point.

*Editor's note—*

Friendly Point is on the east coast of Queensland north of Cooktown.

---

**5 Vehicle used solely to cross roads within an agricultural property**

A vehicle—

- (a) whose registered operator, or at least 1 of whose registered operators, is the sole or joint operator of an agricultural property; and
- (b) used on a road solely to cross roads within the property that need to be crossed by the vehicle to operate the property.

**6 Vehicle used solely to travel between 2 agricultural properties, or 2 mining properties, directly across the road from each other**

A vehicle if—

- (a) its registered operator, or at least 1 of its registered operators, is the sole or joint operator of—
  - (i) an agricultural property, or a property solely or partly used for mining, with a frontage (the *first frontage*) to a side of a road; and
  - (ii) a separate agricultural property, or property solely or partly used for mining, with a frontage (the *second frontage*) to the opposite side of the road; and
- (b) part or all of the first frontage is directly opposite part or all of the second frontage; and
- (c) the vehicle is used on a road solely to travel along the road for no more than 2km between the properties.

*Example of the travel—*

travel along the road for 2km between a gated entry and exit on one of the properties to an undeveloped entry and exit on the other property

**7 Vehicle used solely for fencing of primary producer's property**

A vehicle—

Schedule 5

---

- (a) whose registered operator, or at least 1 of whose registered operators, is the sole or joint operator of a property used for carrying on the registered operator's business as a primary producer; and
- (b) used on a road solely to travel on roads within the property, or onto which the property has a frontage, to build, maintain or remove the property's fences.

**8 Vehicle used solely as a mobile workshop for carrying on business of beekeeping**

A vehicle used on a road solely as a mobile workshop for carrying on the vehicle's registered operator's business of beekeeping.

**9 Vehicle used solely to cross roads within a mining property**

A vehicle—

- (a) whose registered operator, or at least 1 of whose registered operators, is the sole or joint operator of a property solely or partly used for mining; and
- (b) used on a road solely to cross roads within the property that need to be crossed by the vehicle to perform the mining.

**10 Vehicle used solely to carry on business of oil, mineral or water exploration**

A vehicle—

- (a) permanently fitted with oil, mineral or water exploration equipment; and
- (b) used on a road solely for carrying on the vehicle's registered operator's business of exploring for oil, minerals or water.

**11 Vehicle used solely for carrying on business of prospecting in particular local government areas**

A vehicle used on a road solely for carrying on the vehicle's registered operator's business of prospecting in 1 or more of the local government areas mentioned in schedule 6.

**12 Vehicle used solely for carrying on business of well boring**

A vehicle—

- (a) permanently fitted with well boring equipment; and
- (b) used on a road solely for carrying on the vehicle's registered operator's business of well boring.

**Schedule 6**      **Local government areas for  
schedule 5, section 11 for  
vehicles used solely to carry on  
business of prospecting**

schedule 5, section 11

Aurukun

Balonne

Barcoo

Barcaldine

Blackall-Tambo

Boulia

Bulloo

Burke

Carpentaria

Central Highlands, other than within a 20km radius of the post  
office at Emerald

Cloncurry

Cook

Croydon

Diamantina

Doomadgee

Etheridge

Flinders

Hope Vale

Isaac

Lockhart River

Longreach



Mapoon

Maranoa, other than within a 20km radius of the post office at Roma

McKinlay

Mornington

Mount Isa, other than within a 20km radius of the principal post office

Murweh

Napranum

Northern Peninsula Area

Paroo

Quilpie

Richmond

Torres

Winton

Wujal Wujal

## **Schedule 7            Grounds for cancellation of registration of registered vehicle**

section 57

- 1 A ground exists to cancel the registration of a registered vehicle if—
  - (a) a defect notice is issued under the Vehicle Standards and Safety Regulation for the vehicle; and
  - (b) the vehicle's registered operator contravenes the requirements of the defect notice; and
  - (c) the chief executive gives the registered operator a written notice (the *warning notice*) stating that a ground will exist to cancel the vehicle's registration under section 19 of the Act at the end of 14 days after the date of the warning notice if the registered operator does not, within that time—
    - (i) comply with the defect notice; or
    - (ii) ask the chief executive to cancel the vehicle's registration; and
  - (d) the chief executive is satisfied that the registered operator has not complied with all the requirements of the defect notice within the 14 days mentioned in paragraph (c); and
  - (e) the registered operator has not asked the chief executive to cancel the vehicle's registration.
- 2 A ground exists to cancel the registration of a registered vehicle if—
  - (a) a requirement is made to the owner or registered operator of the vehicle by a notice under section 36 of the Act for the inspection of the vehicle; and

- 
- (b) the owner or registered operator fails to comply with the requirement; and
  - (c) the chief executive gives the registered operator a written notice (the **warning notice**) stating that a ground will exist to cancel the vehicle's registration under section 19 of the Act at the end of 14 days after the date of the warning notice if, within that time—
    - (i) the owner or registered operator does not comply with the requirement; or
    - (ii) the registered operator does not ask the chief executive to cancel the vehicle's registration; and
  - (d) the chief executive is satisfied the requirement has not been complied with within the 14 days mentioned in paragraph (c); and
  - (e) the registered operator has not asked the chief executive to cancel the registration.
- 3 A ground exists to cancel the registration of a registered vehicle if—
- (a) a requirement is made to the owner, registered operator or person in control of the vehicle by a notice under section 37 of the Act not to use the vehicle, or permit it to be used, on a road or public place until the circumstance provided for in section 37(1)(a) or (b) of the Act is satisfied; and
  - (b) the owner, registered operator or person in control of the vehicle contravenes the requirement.
- 4 A ground exists to cancel the registration of a registered vehicle if—
- (a) a vehicle defect notice is issued under the Heavy Vehicle National Law (Queensland), section 526 for the vehicle; and
  - (b) the vehicle defect notice has not been cleared by the Regulator under section 530 of that Law; and
  - (c) the chief executive gives the registered operator a written notice (the **warning notice**) stating that a ground

- will exist to cancel the vehicle's registration under section 19 of the Act at the end of 14 days after the date of the warning notice if, within that time—
- (i) the vehicle defect notice is not cleared by the Regulator under section 530 of that Law; or
  - (ii) the registered operator does not ask the chief executive to cancel the vehicle's registration; and
- (d) the chief executive is satisfied the vehicle defect notice has not been cleared by the Regulator within the 14 days mentioned in paragraph (c); and
- (e) the registered operator has not asked the chief executive to cancel the registration.
- 5 A ground exists to cancel the registration of a registered vehicle if—
- (a) a requirement is made to the owner or registered operator of the vehicle by a notice under the *Police Powers and Responsibilities Act 2000*, section 66 not to use the vehicle, or permit it to be used, on a road until the circumstance provided for in section 66(1)(a) or (b) of that Act is satisfied; and
  - (b) the owner or registered operator of the vehicle contravenes the requirement.
- 6 A ground exists to cancel the registration of a registered heavy vehicle if—
- (a) the registered operator or person in charge of the vehicle is required by a notice under the Heavy Vehicle National Law (Queensland), section 522 to produce the vehicle for inspection; and
  - (b) the registered operator or person in charge of the vehicle fails to comply with the requirement; and
  - (c) the chief executive gives the registered operator a written notice (a **warning notice**) stating that a ground will exist to cancel the vehicle's registration under section 19 of the Act at the end of 14 days after the date of the warning notice if, by that time—

- 
- (i) the registered operator or person in charge of the vehicle does not comply with the requirement; or
  - (ii) the registered operator does not ask the chief executive to cancel the vehicle's registration; and
  - (d) the chief executive is satisfied the requirement has not been complied with within the 14 days mentioned in paragraph (c); and
  - (e) the registered operator has not asked the chief executive to cancel the registration.
- 7 A ground exists to cancel the registration of a registered vehicle if—
- (a) the vehicle, or a part of the vehicle, is subject to the *Consumer Goods (Motor Vehicles With Affected Takata Airbag Inflators and Specified Spare Parts) Recall Notice 2018* (Cwlth) (the **recall notice**); and
  - (b) the ACCC gives the chief executive written advice that—
    - (i) the supplier of the vehicle is considered to have complied with its obligations to replace affected airbag inflators under the recall notice; and
    - (ii) an affected airbag inflator fitted within the vehicle has not been replaced in compliance with the recall notice; and
  - (c) the chief executive reasonably believes that each affected airbag inflator fitted within the vehicle has not been replaced in compliance with the recall notice.

## Schedule 8 Dictionary

### section 3

**ACCC** means the Australian Competition and Consumer Commission established by the *Competition and Consumer Act 2010* (Cwlth).

**address** means place of residence or business or, for a corporation, its registered office or place of business.

**administrative fee for late payment** means an administrative fee for late payment under schedule 3.

**affected airbag inflator** means an Affected Takata Airbag Inflator under the *Consumer Goods (Motor Vehicles With Affected Takata Airbag Inflators and Specified Spare Parts) Recall Notice 2018* (Cwlth), section 4.

**agricultural implement** means a vehicle without its own automotive power, built to perform agricultural tasks.

*Examples—*

augers, conveyors, empty field bins, irrigating equipment and machinery fully carried on the three-point linkage of a tractor

**agricultural machine** means a machine with its own automotive power—

- (a) built to perform agricultural tasks; and
- (b) being used for agricultural purposes.

*Examples—*

tractors and harvesters being used for agricultural purposes

**AIS** means an AIS under the *Transport Operations (Road Use Management—Accreditation and Other Provisions) Regulation 2015*.

**allowable modification**, for a learner approved motorbike, means—

- (a) a modification that is—

- (i) designed to enable a person with a physical impairment to ride the motorbike, other than a modification that increases the maximum engine power of the motorbike; and
- (ii) approved under the Vehicle Standards and Safety Regulation; or

*Example—*

modification of the motorbike's foot controls to enable the driver to operate the motorbike by hand controls

- (b) a modification to the motorbike's seating capacity approved under the Vehicle Standards and Safety Regulation.

***ambulance vehicle*** means a motor vehicle used solely for giving emergency treatment and pre-hospital patient care to, and the transport of, sick or injured persons by an ambulance service or hospital.

***application***, for part 10, division 3A, see section 109A.

***approval***, for part 8, division 3, see section 81.

***approved examiner*** see the *Transport Operations (Road Use Management—Accreditation and Other Provisions) Regulation 2015*, schedule 7.

***approved written-off vehicle examiner*** means a person approved by the chief executive to perform written-off vehicle inspections.

***approved written-off vehicle nominee*** means a person approved by the chief executive to supervise the day-to-day running of written-off vehicle inspections for a person.

***articulated bus*** means a bus with 2 or more rigid sections connected to one another in a way allowing—

- (a) passenger access between the sections; and
- (b) rotary movement between the sections.

***ATM*** (aggregate trailer mass), for a trailer—

- (a) means the maximum mass, specified by the manufacturer, for the loaded trailer; and

- (b) includes any mass imposed on the vehicle towing the trailer when they are on a horizontal surface.

***auctioneer*** means a person who carries on a business that includes selling or attempting to sell or offering for sale or resale notifiable vehicles, or parts of notifiable vehicles having a chassis number or VIN, by auction.

***Australian Design Rule*** means a national standard under the *Motor Vehicle Standards Act 1989* (Cwlth), part 2.

***auto parts dismantler*** means a person who carries on the business of—

- (a) demolishing or dismantling vehicles or vehicle parts or accessories; or
- (b) buying vehicles and substantially demolished or substantially dismantled vehicles and selling substantially demolished or substantially dismantled vehicles, whether or not the person also sells vehicle parts or accessories.

***axle*** means 1 or more shafts positioned in a line across a vehicle, on which 1 or more wheels intended to support the vehicle turn.

***axle group*** means a single axle group, tandem axle group, twinsteer axle group, tri-axle group, quad-axle group or multi-axle group.

***B-double lead trailer*** means a semitrailer that is nominated for use as the lead trailer in a B-double.

***B-triple*** means a combination consisting of a prime mover towing 3 semitrailers.

***B-triple lead trailer*** means a semitrailer that is nominated for use as the lead trailer in a B-triple.

***B-triple middle trailer*** means a semitrailer that is nominated for use as the second trailer in a B-triple.

***bus*** means a motor vehicle built mainly to carry 10 or more seated adults, including the driver.

***bus (type 1)*** means a rigid bus with 2 axles and an MRC of not more than 12t.



**bus (type 2)** means a rigid bus with—

- (a) 2 axles and an MRC of more than 12t; or
- (b) 3 or more axles.

**caravan** means an enclosed trailer designed for people to live in.

**card holder** means a person who holds—

- (a) a pensioner concession card; or
- (b) a seniors card.

**category 1 vehicle** means a vehicle with a GVM, GCM or ATM of not more than 4.5t.

**category 2 vehicle** means a vehicle with a GVM, GCM or ATM of more than 4.5t.

**chassis number**, of a vehicle, means an identification number of the vehicle's chassis that is permanently marked on the chassis or another part of the vehicle, but does not include the vehicle's VIN.

**client user**, for part 10, division 5, see section 112.

**community service organisation** means an organisation established for the purpose of providing any of the following to persons in distress—

- (a) care, relief or support;
- (b) housing;
- (c) education or instruction, whether mental, physical, technical, social, spiritual or otherwise;
- (d) any other help.

**concessional registration**, for a vehicle, means concessional registration granted under part 11, division 3 or 4 for the registration of the vehicle.

**conditionally registered** means registered under section 12(2).

**conditionally registered vehicle** means a vehicle registered under section 12(2).

***conditional registration*** see section 12(2).

***converter dolly*** means a trailer with a fifth wheel coupling designed to support a semitrailer for hauling purposes.

***CTP insurance premium*** means the insurance premium payable under the *Motor Accident Insurance Act 1994* for an insurance certificate under that Act.

***current postal address***, for a person, means a postal address—

- (a) given by the person to the department for use by the department (whether or not it was given for the purpose of this regulation); and
- (b) for which no written or oral notice from the person, requiring the department to discontinue use of the postal address, has been received by the department.

***customised number plate*** see section 36(2).

***damaged*** includes significantly deteriorated.

***dealer*** means—

- (a) the holder of a motor dealer licence under the *Motor Dealers and Chattel Auctioneers Act 2014* or, other than in section 106, the holder of an equivalent licence or other authority under a corresponding law to that Act; or
- (b) a person whose business is the sale of new motor vehicles, or new or used trailers.

***dealer plate*** means a number plate included in a series of number plates designated by the chief executive as dealer plates.

***dealer's premises*** means the premises where a dealer carries on business—

- (a) including any part of the premises used for car parking or for inspecting, repairing, servicing or cleaning motor vehicles; and
- (b) excluding any road-related area adjacent to the premises.

**dealer's stock** means any motor vehicle, whether registered or unregistered, kept at a dealer's premises for the purpose of sale or display for sale, and includes each of the following—

- (a) a motor vehicle that is being inspected, repaired, serviced or cleaned before being sold or displayed for sale;
- (b) a motor vehicle that has been sold by the dealer and is ready for delivery to the purchaser.

**defence force member** means—

- (a) a person on full-time permanent service with the Australian Defence Force; or
- (b) a person on full-time duty with the Australian Defence Force Reserve.

**direct debit arrangement** means an arrangement, on terms approved by the chief executive, that allows an amount payable by a person to the chief executive to be paid, by direct debit, from an account the person holds with a financial institution.

**dog trailer** means a trailer with—

- (a) 1 axle group or a single axle at the front that is connected to the towing vehicle by a drawbar; and
- (b) 1 axle group or single axle at the rear.

**drawbar** means a part of a trailer, other than a semitrailer, that connects the trailer body to a coupling for towing purposes.

**drawn plant** means a machine built on a trailer base, other than an agricultural implement.

**drought declaration**, for part 9, division 2, see section 100B.

**drought-declared area**, for part 9, division 2, see section 100B.

**drought-declared property**, for part 9, division 2, see section 100B.

**electronic communication**, for part 10, division 3A, see the *Electronic Transactions (Queensland) Act 2001*, schedule 2.

**eligible person**, for part 10, division 5, see section 112.

**engine capacity**, for a motorbike, means the engine capacity—

- (a) under the manufacturer's specifications for the motorbike; or
- (b) stated in a LAM test report for the motorbike.

**exempt vehicle** see section 4.

**fifth wheel coupling** means a device, other than the upper rotating element and the kingpin (that are parts of a semitrailer), used with a prime mover, semitrailer or a converter dolly to permit quick coupling and uncoupling and to provide for articulation.

**fire and emergency appliance** means a vehicle—

- (a) built or modified for—
  - (i) fighting fires; or
  - (ii) supporting or performing rescue operations; and
- (b) operated by authorised fire officers under the *Fire and Emergency Services Act 1990*.

**freestyle motocross** means a competition to compare competitors' skills, or an event to demonstrate a rider's skills, in performing motorbike acrobatics on a motorbike that has been ridden off a ramp.

**freestyle motocross area** means an area not dedicated to public use as a road, from which other traffic is excluded while it is being used to perform the riding involved in freestyle motocross.

**garage address**, of a vehicle, means the principal depot or base of operations of the vehicle.

**gas certificate**, for a gas system in a vehicle, means—

- (a) for a new vehicle—the certificate or plate for the system required under the *Petroleum and Gas (Safety) Regulation 2018*, section 105 or 115 before the vehicle may be offered for sale; or

- (b) for a used vehicle—the certificate for the system required under the *Petroleum and Gas (Safety) Regulation 2018*, section 106 or 116 to be given, upon a sale or transfer of the vehicle, to the person to whom the vehicle is sold or transferred.

**gas system** see the *Petroleum and Gas (Production and Safety) Act 2004*, schedule 2.

**GCM** (gross combination mass), of a motor vehicle, means the maximum loaded mass for the motor vehicle and any vehicles it may lawfully tow—

- (a) stated by the vehicle’s manufacturer—
- (i) on the vehicle’s compliance plate; or
  - (ii) if there is no compliance plate—in another place; or
- (b) stated by the chief executive or the corresponding authority under a corresponding law to the Act, if—
- (i) the vehicle’s manufacturer has not stated the vehicle’s maximum loaded mass; or
  - (ii) the manufacturer can not be identified; or
  - (iii) the vehicle has been modified and the maximum loaded mass stated by the manufacturer is no longer appropriate; or
- (c) stated in an evaluation report about the vehicle given by an accredited person.

**give**, in relation to information, for part 10, division 5, see section 112.

**GTMR** (gross trailer mass rating), of a trailer, means the mass transmitted to the ground by the axles of the trailer when—

- (a) coupled to a towing vehicle; and
- (b) carrying its maximum load approximately uniformly distributed over the trailer’s load bearing area.

**heavy vehicle standards exemption** means the vehicle standards exemption (notice) under the Heavy Vehicle National Law (Queensland) applying—

- (a) in relation to particular requirements under the heavy vehicle standards under that Law; and
- (b) for the purposes of conditional registration.

**historic ambulance vehicle** means a vehicle that was used as an ambulance vehicle but is now used for display by an ambulance service or historical ambulance society.

**historic firefighting equipment** means a vehicle that was used for firefighting but is now used for display by an historical fire brigade society.

**identifying number**, of a vehicle, means—

- (a) a chassis number; or
- (b) an engine number; or
- (c) a VIN.

**information**, for part 10, division 3A, subdivision 1, see section 109A.

**insolvency entity**, for part 10, division 5, see section 112.

**insurer** means a body corporate authorised under the *Insurance Act 1973* (Cwlth) to carry on insurance business.

**interstate register**, for part 10, division 5, see section 112.

**involved person**, for part 10, division 5, see section 112.

**LAM information**, for part 3, division 4, see section 26.

**LAM test report** see section 27.

**late-model vehicle** means a vehicle that is not more than 16 years old, counting from—

- (a) the last day of the month in which the vehicle was manufactured; or
- (b) if the month in which the vehicle was manufactured is not known—the last day of the year in which the vehicle was manufactured.

**lead trailer**, in a combination, means the trailer that is, or that is to be, attached to the prime mover.

**learner approved motorbike** means a production motorbike—

- 
- (a) that—
    - (i) is fitted with an electric motor; or
    - (ii) has an internal-combustion engine with an engine capacity of not more than 660mL; and
  - (b) with a power-to-weight ratio of not more than 150kW per tonne; and
  - (c) that has not been modified other than for an allowable modification; and
  - (d) that is stated to be a learner approved motorbike in a list kept by the chief executive and published on the whole-of-government website.

**limited access registration**, for a conditionally registered vehicle, means registration that results in the vehicle being subject to conditions for use, stated in the safe movement guideline or heavy vehicle standards exemption, that allow the vehicle to be used only in a stated area or only for a stated purpose.

**litigation**, for part 10, division 5, see section 112.

**load**, of a vehicle, includes—

- (a) anything normally taken from the vehicle when it is not in use; and
- (b) anything that may fall from the vehicle when it is in motion.

**loaded mass**, of a vehicle, means the vehicle's mass together with the mass of the vehicle's load transmitted to the ground.

**local government area** means a local government area under the *Local Government Act 2009*.

**long combination truck** means a truck nominated to tow 2 or more trailers.

**loss adjuster** means a person who assesses the extent of loss or damage involving a vehicle for another person.

**lowest premium set by any CTP insurer** means the lowest CTP insurance premium set by any licensed insurer under the *Motor Accident Insurance Act 1994*, section 13A for the class

of CTP insurance that relates to the vehicle for which an application for renewal of registration has been made.

**low loader** means a gooseneck semitrailer with a loading deck 1m or less above the ground.

**low loader dolly** means a trailer that—

- (a) is of the type usually coupled between a prime mover and a low loader; and
- (b) consists of a gooseneck rigid frame; and
- (c) does not carry any load directly on itself; and
- (d) is equipped with 1 or more axles, a kingpin and a fifth wheel coupling.

**low-powered motor vehicle** means a motor vehicle that—

- (a) does not have an internal-combustion engine; and
- (b) is propelled by—
  - (i) a motor with a maximum power output of not more than 200W; or
  - (ii) 2 or more motors with a combined maximum power output of not more than 200W.

**maximum engine power**, for a motorbike, means the maximum engine power—

- (a) under the manufacturer's specifications for the motorbike; or
- (b) stated in a LAM test report for the motorbike.

**medium combination truck** means a truck, other than a short combination truck, nominated to haul 1 trailer.

**mobile machinery** means a motor vehicle that—

- (a) is built to transport and operate machinery or equipment forming an integral part of the vehicle; and
- (b) is not—
  - (i) a truck, semitrailer or prime mover; or
  - (ii) a tow truck; or



(iii) a vehicle that may be conditionally registered.

***motorised caravan*** means a motor vehicle designed mainly for people to live in.

***motorised golf buggy*** means a motor vehicle that—

- (a) is designed as transport for persons playing, or persons associated with persons playing, golf; and
- (b) can not be driven faster than 10km/h.

***motorised wheelchair*** means a motor vehicle that—

- (a) is designed and built for use by a seated person with mobility difficulties; and
- (b) is not capable of going faster than 10km/h; and
- (c) has a tare of not more than 150kg; and
- (d) is not propelled by an internal-combustion engine.

***motor race*** means a race involving motor vehicles, or a practice, or a time trial, for a race or competition involving 1 or more motor vehicles.

***MRC*** (mass rating for charging), of a vehicle, means the maximum permissible mass of the vehicle and its load—

- (a) shown on the vehicle's compliance plate as the GVM, GTMR or ATM of the vehicle; or
- (b) for a vehicle without a compliance plate—decided by the chief executive or the corresponding authority under a corresponding law to the Act, having regard to the design and construction of—
  - (i) the vehicle; or
  - (ii) any of its components.

***multi-axle group*** means—

- (a) for a dog trailer—5 or more axles at the front or at the rear, or 5 or more axles at the front and 5 or more axles at the rear; or
- (b) for a pig trailer—5 or more axles near the middle of the load carrying surface of the trailer; or

Schedule 8

---

- (c) for a semitrailer—5 or more axles towards the rear of the trailer; or
- (d) for a B-double lead trailer or B-triple lead trailer or B-triple middle trailer—5 or more axles towards the rear of the trailer; or
- (e) for a converter dolly or low loader dolly—5 or more axles located under the fifth wheel coupling.

***multi-combination prime mover*** means a prime mover nominated to haul 2 or more trailers.

***national heavy vehicle number plate*** means a plate designed to be attached to a category 2 vehicle to identify the vehicle.

***natural disaster relief notice***, for part 9, division 1, see section 96(2).

***NEVDIS***, for part 10, division 5, see section 112.

***nominated***, in relation to a vehicle, means nominated in an application for registration of the vehicle.

***nominated configuration***, for a category 2 vehicle, means the configuration in which the vehicle is nominated to operate for the term of its registration.

***notifiable information***, for a written-off vehicle, means—

- (a) the vehicle's chassis number or VIN; and
- (b) the vehicle's engine number, if available; and
- (c) if the vehicle has been assessed as a total loss—when the vehicle was assessed to be a total loss; and
- (d) whether the vehicle is a repairable write-off or a statutory write-off; and
- (e) the type, location and severity of the damage to the vehicle; and
- (f) details of the person providing the information mentioned in paragraphs (a) to (e).

***notifiable vehicle*** means—

- (a) a vehicle that—

- 
- (i) is a late-model vehicle of 1 of the following types—
    - (A) a motor vehicle with a GVM not over 4.5t;
    - (B) a motorbike;
    - (C) a caravan;
    - (D) a trailer with an ATM over 4.5t; and
  - (ii) complies with the requirements of all Australian Design Rules applying to it; or
  - (b) any other vehicle of a type notified by the chief executive by gazette notice.

***notifier*** means any of the following—

- (a) an insurer;
- (b) a self-insurer;
- (c) a loss adjuster;
- (d) a dealer;
- (e) an auctioneer;
- (f) an auto parts dismantler.

***observed trial*** means a competition to compare competitors' skills, or an event to demonstrate a rider's skills, in riding a motorbike around a marked course, 1 at a time.

***observed trial area*** means an area not dedicated to public use as a road, from which other traffic is excluded while it is being used as a course for an observed trial.

***passengers***, of a vehicle, does not include the driver or a trainee driver of the vehicle or a person in the vehicle who is necessary for the normal operation of the vehicle.

***pensioner concession card*** means a card known as a pensioner concession card issued under a Commonwealth law.

***Personal Hardship Assistance Scheme***, for part 9, division 1, see section 95.

***personal information***, for part 10, division 5, see section 112.

**personalised number plate** means a number plate issued under section 33 as a personalised number plate.

**pig trailer** means a trailer—

- (a) with 1 axle group or a single axle near the middle of its load carrying surface; and
- (b) that is connected to the towing vehicle by a drawbar.

**plant** means a machine with its own automotive power.

**pole-type trailer** means a trailer that—

- (a) is attached to a towing vehicle by a pole, or an attachment fitted to the pole; and
- (b) is ordinarily used for transporting loads, such as logs, pipes, structural members, or other long objects, that are generally capable of supporting themselves like beams between supports.

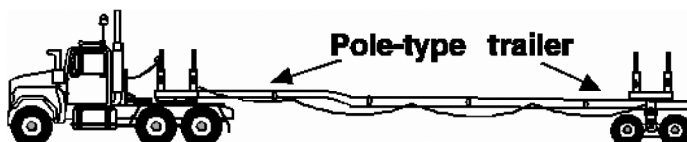

**power-to-weight ratio**, for a learner approved motorbike, is a ratio—

- (a) expressed in kilowatts per tonne; and
- (b) calculated by—
  - (i) dividing the maximum engine power by the sum of the tare mass and 90kg; and
  - (ii) multiplying the product of the division by 1,000.

*Example—*

The power-to-weight ratio of a motorbike that has a maximum engine power of 54kW and a tare mass of 360kg is calculated by dividing 54kW by the sum of 360kg and 90kg (that is, 450kg) and multiplying the product of the division by 1,000. In this example, the power-to-weight ratio is 120kW/t.

**prescribed concession information**, about a person, means information from a State or Commonwealth government agency that shows a change in the person's status as a card holder.

***prescribed evidence***, of a current inspection certificate under the Vehicle Standards and Safety Regulation, means—

- (a) for a current inspection certificate issued under that regulation using an electronic method—the certificate number of the certificate; or
- (b) otherwise—the current certificate under that regulation.

***prescribed private use vehicle***, for schedule 1 and schedule 3, item 11, means a category 1 vehicle mentioned in schedule 1, item 1, 2, 3 or 4, if the vehicle's purpose of use is recorded as private purposes in the register.

***prescribed service person*** means a person who—

- (a) resides in Queensland; and
- (b) is, or has previously been, a defence force member; and
- (c) has either—
  - (i) been assessed under the *Veterans' Entitlements Act 1986* (Cwlth) as having at least a 70% degree of incapacity; or
  - (ii) been assessed under the *Military Rehabilitation and Compensation Act 2004* (Cwlth) as having at least 50 impairment points.

***prescribed vehicle*** means—

- (a) a prime mover or truck with a GVM of at least 6t; or
- (b) a trailer with an MRC over 4.5t.

***primary produce*** means raw material for clothing or food derived from—

- (a) agriculture; or
- (b) dairying; or
- (c) fishing; or
- (d) the raising of livestock; or
- (e) viticulture.

***primary producer*** means a person engaged mainly in the production of primary produce.

***primary production vehicle*** means a vehicle that is—

- (a) owned by a person who is a primary producer; and
- (b) used only for carrying on the person's business as a primary producer; and
- (c) either of the following—
  - (i) a prime mover or truck with a GVM of at least 6t;
  - (ii) a trailer with an MRC of over 4.5t.

***production motorbike*** means a motorbike that—

- (a) is manufactured and marketed in volume for normal road use; and
- (b) conforms with the requirements applying to the motorbike under each vehicle law.

***public access provider***, for part 10, division 5, see section 112.

***quad-axle group*** means a group of 4 axles, in which the horizontal distance between the centre-lines of the outermost axles is more than 3.2m but not more than 4.9m.

***quad bike*** means a 4-wheeled motor vehicle that is ridden in the same way as a 2-wheeled motor vehicle.

***racing track*** means a circuit or track, not dedicated to public use as a road, being used as a course for a motor race or motor race driver training, if other traffic is excluded from the circuit or track during its use for the race or training.

***racing vehicle*** means a vehicle that is used in a motor race or for motor race driver training.

***recklessly*** includes with gross negligence.

***register***, as a noun, see section 18.

***registered operator***, of a vehicle or dealer plate, see section 5.

***registration certificate*** means—

- (a) for a vehicle—a certificate issued by the chief executive that includes the matters about the vehicle listed in section 19(2); or

- (b) for a personalised number plate—a certificate issued by the chief executive that includes the matters about the plate mentioned in section 33(2)(c); or
- (c) for a dealer plate—a certificate issued by the chief executive that includes the matters about the plate listed in section 62(5).

**registration number** means a distinguishing number—

- (a) assigned by the chief executive to identify a vehicle that is, or has been, registered; and
- (b) displayed, or intended for display, on a number plate.

**registration-related amount**, for a renewal of registration, means the total of the following fees payable for the registration under section 43(1A)—

- (a) any vehicle registration fee under schedule 1 or 2 for the vehicle;
- (b) any registration administration fee for a conditionally registered vehicle under schedule 3 for the vehicle;
- (c) if the vehicle is a category 1 vehicle—the traffic improvement fee under schedule 3 for the vehicle;
- (d) if the vehicle is a category 2 vehicle, other than a trailer—the registration administration fee under schedule 3 for the vehicle;
- (e) any CTP insurance premium.

**related area**, for a racing track, means an area—

- (a) adjacent to the racing track where a racing vehicle is parked or driven for a purpose associated with a motor race or motor race driver training; and
- (b) not dedicated to public use as a road.

**relevant registration term**, for a vehicle, means—

- (a) if the vehicle may be registered for a term of 3 months under section 22(c)—3 months; or
- (b) otherwise—6 months.

**renewal notice** see section 42.

***repairable write-off***—

- (a) means a notifiable vehicle that is a total loss but is not a statutory write-off; and
- (b) in the context of a written-off vehicle inspection and a written-off vehicle inspection report, includes a vehicle with a chassis number or VIN that is the same as the chassis number or VIN of a vehicle recorded in the register, or in a register kept under a corresponding law to this regulation, as a repairable write-off.

***repealed regulation*** means the repealed *Transport Operations (Road Use Management—Vehicle Registration) Regulation 1999*.

***required evidence or notice***, for part 9, division 2, see section 100B.

***road-related area*** means an area that is part of a road and—

- (a) divides a part of the road from another part of the road and is formed by lines marked on the road or is constructed on the road; or

*Example*—

a traffic island

- (b) is a footpath or nature strip; or
- (c) is open to the public and is designed for use by cyclists or animals.

***safe movement guideline*** means the guideline under the Vehicle Standards and Safety Regulation, section 14 for the safe movement of vehicles on a road applying—

- (a) in relation to particular requirements under the vehicle standards under that regulation; and
- (b) for the purposes of conditional registration.

***safety recall agency***, for part 10, division 5, see section 112.

***sale***, of a vehicle, includes—

- (a) the hiring of the vehicle on hire-purchase; and
- (b) the leasing of the vehicle.



**section 48 notice** see section 109E(1).

**self-insurer** means an entity that owns 5 or more notifiable vehicles for which there is no insurance policy with an insurer covering loss or damage.

**semitrailer** means a trailer (including a pole-type trailer) that has—

- (a) 1 axle group or a single axle towards the rear; and
- (b) a means of attachment to a prime mover or a converter dolly that results in some of the load being imposed on the prime mover or converter dolly.

**seniors card** means a Queensland Government seniors card.

**short combination prime mover** means a prime mover nominated to tow 1 semitrailer.

**short combination truck** means a truck nominated to haul 1 trailer, if the combination has—

- (a) 6 or less axles; and
- (b) a total mass of not more than 42.5t.

**single axle** means an axle not forming part of an axle group.

**single axle group** means a group of 2 or more axles, in which the horizontal distance between the centre-lines of the outermost axles is less than 1m.

**special edition number plate** means a number plate showing a design or theme representing an event, occasion or achievement, but does not include a personalised number plate.

**special interest vehicle** means—

- (a) a vehicle that is at least 30 years old; or
- (b) an historic ambulance vehicle or historic firefighting equipment; or
- (c) a street rod vehicle; or
- (d) a bus that is at least 25 years old with a GVM over 5t.

**special plate** means—

- (a) a customised number plate; or
- (b) a personalised number plate.

***special purpose vehicle*** means—

- (a) a forklift, straddle carrier, mobile cherry picker or mobile crane, other than a vehicle that may be conditionally registered; or
- (b) a vehicle, other than a vehicle mentioned in paragraph (a) or a caravan, motorised caravan, mobile library, mobile workshop, mobile laboratory or mobile billboard, that has been built, or permanently modified, for a purpose other than for carrying goods or passengers.

***special purpose vehicle (type o)*** means a special purpose vehicle, other than a special purpose vehicle (type p), that—

- (a) is built, or permanently modified, primarily for use on roads; and
- (b) has at least 1 axle or axle group loaded above the mass limits stated in the *Heavy Vehicle (Mass, Dimension and Loading) National Regulation*, schedule 1, part 2, table 1.

***special purpose vehicle (type p)*** means a special purpose vehicle, other than a vehicle that may be conditionally registered, built or permanently modified for—

- (a) off-road use; or
- (b) use on a road-related area; or
- (c) use on an area of road that is under construction.

***special purpose vehicle (type t)*** means a special purpose vehicle, other than a special purpose vehicle (type p), that—

- (a) is built, or permanently modified, primarily for use on roads; and
- (b) has no axle or axle group loaded above the mass limits stated in the *Heavy Vehicle (Mass, Dimension and Loading) National Regulation*, schedule 1, part 2, table 1.

*Examples of special purpose vehicle (type t)—*

boring plant, fire-engine, mobile crane and truck-mounted concrete pump

**statutory entity**, for part 10, division 5, see section 112.

**statutory write-off** means a notifiable vehicle that is a total loss because of—

- (a) damage by corrosion; or
- (b) damage that satisfies the statutory write-off assessment criteria for the vehicle.

**statutory write-off assessment criteria** means—

- (a) for a notifiable vehicle that is a motor vehicle with a GVM not over 4.5t—the criteria mentioned in the document entitled *Damage Assessment Criteria for the Classification of Statutory Write-Offs (National Written-Off Vehicle Criteria)*, as approved by the chief executive; or
- (b) for a notifiable vehicle that is a trailer with an ATM over 4.5t, a motorbike, a caravan or a vehicle of a type notified by the chief executive by gazette notice—the criteria mentioned in the document entitled *Damage Assessment Criteria for the Classification of Statutory Write-Offs—Motorbikes, Caravans, Heavy Trailers and Other Vehicles*, as approved by the chief executive.

*Editor's note—*

The documents mentioned in paragraphs (a) and (b), as approved by the chief executive, are available on the department's website.

**street rod vehicle** means a motor vehicle modified for safe road use that—

- (a) has a body and frame built before 1949; or
- (b) is a replica of a motor vehicle the body and frame of which were built before 1949.

**supplier**, of a vehicle, means a Supplier under the *Consumer Goods (Motor Vehicles With Affected Takata Airbag Inflators and Specified Spare Parts) Recall Notice 2018* (Cwlth), section 4.

**tandem axle group** means a group of at least 2 axles, in which the horizontal distance between the centre-lines of the outermost axles is at least 1m but not more than 2m.

**tare mass**, for a motorbike, means the mass of the motorbike—

- (a) with all fluid reservoirs on the motorbike, other than the fuel tank, filled to a normal operating level; and
- (b) with the fuel tank empty; and
- (c) with all standard equipment and any optional items of equipment fitted; and
- (d) without the weight of a motorbike rider or a passenger.

**total loss** means a notifiable vehicle—

- (a) damaged by corrosion to the extent that the vehicle's fair salvage value, when added to the cost of repairing the vehicle for use on a road or road-related area, would be more than the fair market value for a vehicle of equivalent make, model and year of manufacture that is not damaged by corrosion; or
- (b) damaged by accident, collision, demolition, dismantling, fire, flood, trespass or other event to the extent that the vehicle's fair salvage value, when added to the cost of repairing the vehicle for use on a road or road-related area, would be more than the vehicle's fair market value immediately before the event that caused the damage.

**tow truck** means a motor vehicle that is—

- (a) equipped with a lifting or loading device capable of being used for the towing of a vehicle; and
- (b) used mainly for carrying on a business of towing abandoned, disabled or damaged vehicles.

**tractor** means a motor vehicle used for towing purposes, other than a motor vehicle—

- (a) designed to carry passengers or goods, other than its own fuel or water; or

(b) that is a tow truck.

**tri-axle group** means a group of at least 3 axles, in which the horizontal distance between the centre-lines of the outermost axles is more than 2m but not more than 3.2m.

**truck** means a rigid motor vehicle built mainly as a load carrying vehicle.

**truck (type 1)** means a truck with—

- (a) 2 axles and an MRC of not more than 12t; or
- (b) 3 axles and an MRC of not more than 16.5t; or
- (c) 4 or more axles and an MRC of not more than 20t.

**truck (type 2)** means a truck with—

- (a) 2 axles and an MRC of more than 12t; or
- (b) 3 axles and an MRC of more than 16.5t; or
- (c) 4 or more axles and an MRC of more than 20t.

**twinsteer axle group** means a group of 2 axles—

- (a) with single tyres; and
- (b) fitted to a motor vehicle; and
- (c) connected to the same steering mechanism; and
- (d) the horizontal distance between the centre-lines of which is at least 1m but not more than 2m.

**unregistered vehicle permit** means a permit issued under section 60(3).

**unrestricted access registration**, for a conditionally registered vehicle, means registration that is not limited access registration or zone access registration.

**use**, of a vehicle on a road, includes standing the vehicle on the road.

**vehicle law** see section 5A.

**vehicle-related information**, for part 10, division 5, see section 112.

**vehicle-related information provider**, for part 10, division 5, see section 117(1).

**Vehicle Standards and Safety Regulation** means the *Transport Operations (Road Use Management—Vehicle Standards and Safety) Regulation 2010*.

**VIN**, of a vehicle, means the unique vehicle identification number assigned to the vehicle.

**walking speed equipment** means a motor vehicle—

- (a) used for construction, maintenance or warehouse operation; and
- (b) designed mainly for use outside the road system; and
- (c) not capable of going faster than 10km/h.

**whole-of-government website** means the website located at [www.qld.gov.au](http://www.qld.gov.au).

**written-off vehicle** means a vehicle that is—

- (a) a repairable write-off; or
- (b) a statutory write-off.

**written-off vehicle inspection** means an inspection of a repairable write-off, under procedures approved by the chief executive, to decide on the vehicle's identity.

**written-off vehicle inspection report** means a report from a written-off vehicle inspection that includes a decision of an approved written-off vehicle examiner that the vehicle's identity is legitimate.

**written-off vehicle inspection site** means a place where written-off vehicle inspections are performed.

**zone access registration**, for a conditionally registered vehicle, means registration that results in the vehicle being subject to conditions for use, stated in the safe movement guideline or heavy vehicle standards exemption, that limit the distance, for each stated zone, that a vehicle may travel on a single journey in the zone.