

# Heavy Vehicle (Vehicle Standards) National Regulation

## Subordinate Legislation 2013 No. 76

made under the

Heavy Vehicle National Law as applied by the *Heavy Vehicle National Law Act 2012* (Qld) and by the law of States and Territories

## Contents

---

		Page
<b>Part 1</b>	<b>Preliminary</b>	
1	Short title . . . . .	8
2	Commencement . . . . .	8
3	Prescription of vehicle standards . . . . .	8
<b>Part 2</b>	<b>Interpretation and provisions about application of vehicle standards</b>	
4	Definitions . . . . .	9
5	References to vehicle include its equipment etc. . . . .	16
6	References to heavy vehicles are references to single heavy vehicles . . . . .	17
7	When restored vehicle is built. . . . .	17
8	Measurement of width of vehicles . . . . .	17
9	Interpretation of particular second edition ADRs . . . . .	17
10	Compliance with particular standards . . . . .	18
11	Compliance with requirement to have particular equipment . . . . .	18
12	Modifications . . . . .	18
<b>Schedule 1</b>	<b>Vehicle standards relating to ADRs applying to single heavy vehicles</b> . . . . .	19
<b>Part 1</b>	<b>Compliance with ADRs</b>	
1	Second edition ADRs . . . . .	19

Contents

2	Third edition ADRs . . . . .	20
<b>Part 2</b>	<b>Exemption from compliance with ADRs</b>	
3	Vehicles that are not road vehicles . . . . .	21
4	Vehicles subject to particular approvals etc. under Motor Vehicle Standards Act . . . . .	21
5	Partial exemption for personally imported vehicles . . . . .	22
<b>Schedule 2</b>	<b>Other vehicle standards applying to single heavy vehicles .</b>	<b>24</b>
<b>Part 1</b>	<b>Preliminary</b>	
1	References to particular trailers are to heavy trailers of that type	24
2	Application to heavy vehicle complying with inconsistent ADR requirement . . . . .	24
3	Application to heavy vehicle subject of Motor Vehicle Standards Act approval . . . . .	25
<b>Part 2</b>	<b>General safety requirements</b>	
4	Steering . . . . .	25
5	Turning ability . . . . .	26
6	Ability to travel backwards and forwards . . . . .	26
7	Protrusions . . . . .	26
8	Driver's view and vehicle controls . . . . .	26
9	Seating . . . . .	27
10	Mudguards . . . . .	27
11	Horns, alarms etc. . . . .	28
12	Rear vision mirrors . . . . .	29
13	Additional rear vision mirrors and mirror surfaces . . . . .	30
14	Automatic transmission . . . . .	30
15	Diesel engines . . . . .	30
16	Bonnet-securing devices . . . . .	30
17	Electrical wiring, connectors and conductors . . . . .	31
18	Television receivers and visual display units . . . . .	32
19	Requirement for windscreen to be fitted . . . . .	33
20	Windscreens and windows . . . . .	33
21	Window tinting . . . . .	34
22	Windscreen wipers and washers . . . . .	35
23	Wheels and tyres—size and capacity . . . . .	36
24	Pneumatic tyres for particular heavy vehicles . . . . .	37
25	Tyres—defects . . . . .	37
26	Tyres—suitability . . . . .	37

27	Retreads . . . . .	37
28	Tyre tread . . . . .	38
<b>Part 3</b>	<b>Vehicle marking</b>	
29	Vehicle and engine identification numbers . . . . .	38
30	White or silver band on particular vehicles . . . . .	39
31	Left-hand drive signs . . . . .	39
<b>Part 4</b>	<b>Vehicle configuration</b>	
32	Axle configuration . . . . .	40
33	Relation between axles in axle group . . . . .	41
<b>Part 5</b>	<b>Dimension requirements</b>	
34	Application of prescribed dimension requirements as a vehicle standard . . . . .	42
<b>Part 6</b>	<b>Lights and reflectors</b>	
<b>Division 1</b>	<b>Application of particular requirements</b>	
35	Part does not apply to particular vehicles . . . . .	42
36	Particular requirements apply only at night . . . . .	43
<b>Division 2</b>	<b>General requirements for lights</b>	
37	Prevention of glare . . . . .	43
38	Pairs of lights . . . . .	43
<b>Division 3</b>	<b>Headlights</b>	
39	Headlights to be fitted to vehicles . . . . .	43
40	How headlights are to be fitted . . . . .	44
41	How additional headlights are to be fitted . . . . .	45
42	Performance of headlights . . . . .	45
43	Effective range of headlights . . . . .	45
44	Changing headlights from high-beam to low-beam position . . . . .	45
<b>Division 4</b>	<b>Parking lights</b>	
45	Parking lights . . . . .	46
<b>Division 5</b>	<b>Daytime running lights</b>	
46	Daytime running lights . . . . .	47
<b>Division 6</b>	<b>Tail-lights</b>	
47	Tail-lights generally . . . . .	48
48	Pattern of fitting tail-lights . . . . .	48
49	Performance of tail-lights . . . . .	48
50	Wiring of tail-lights . . . . .	49

Contents

---

<b>Division 7</b>	<b>Number plate lights</b>	
51	Number plate lights . . . . .	49
<b>Division 8</b>	<b>Clearance lights</b>	
52	Front clearance lights . . . . .	50
53	External cabin lights . . . . .	51
54	Rear clearance lights . . . . .	51
<b>Division 9</b>	<b>Side marker lights</b>	
55	Vehicles needing side marker lights . . . . .	52
56	Location of side marker lights. . . . .	52
57	Performance of side marker lights . . . . .	53
58	Side marker lights and rear clearance lights . . . . .	54
<b>Division 10</b>	<b>Brake lights</b>	
59	Fitting brake lights . . . . .	54
60	Performance and operation of brake lights. . . . .	55
<b>Division 11</b>	<b>Reversing lights</b>	
61	Reversing lights . . . . .	56
<b>Division 12</b>	<b>Direction indicator lights</b>	
62	Direction indicator lights on heavy motor vehicles . . . . .	56
63	Direction indicator lights on trailers . . . . .	57
64	Location of direction indicator lights . . . . .	57
65	Operation and visibility of direction indicator lights. . . . .	58
<b>Division 13</b>	<b>Fog lights</b>	
66	Front fog lights . . . . .	60
67	Rear fog lights . . . . .	60
<b>Division 14</b>	<b>Interior lights</b>	
68	Interior lights. . . . .	61
<b>Division 15</b>	<b>Reflectors</b>	
69	General requirements for reflectors . . . . .	61
70	Rear reflectors . . . . .	62
71	Compulsory side reflectors on pole-type trailers . . . . .	62
72	Optional side reflectors. . . . .	63
73	Compulsory front reflectors on particular trailers . . . . .	63
74	Optional front reflectors . . . . .	64
<b>Division 16</b>	<b>Warning lights and signs on buses carrying children</b>	
75	Application of Div 16. . . . .	65
76	Fitting of warning lights and signs . . . . .	65

77	Operation and performance of warning lights . . . . .	66
78	Specifications for warning signs . . . . .	67
<b>Division 17</b>	<b>Other lights, reflectors, rear marking plates or signals</b>	
79	Other lights and reflectors . . . . .	68
80	Rear marking plates . . . . .	69
81	Signalling devices . . . . .	70
82	Mechanical signalling devices . . . . .	71
83	Turn signals . . . . .	72
<b>Part 7</b>	<b>Braking systems</b>	
<b>Division 1</b>	<b>Brake requirements for all heavy vehicles</b>	
84	Components of a braking system . . . . .	72
85	Provision for wear . . . . .	73
86	Supply of air or vacuum to brakes . . . . .	73
87	Performance of braking systems . . . . .	75
<b>Division 2</b>	<b>Heavy motor vehicle braking systems</b>	
88	What braking system a heavy motor vehicle must have . . . . .	76
89	Operation of brakes on heavy motor vehicles . . . . .	77
90	Air or vacuum brakes on heavy motor vehicles . . . . .	78
<b>Division 3</b>	<b>Heavy trailer braking systems</b>	
91	What brakes a heavy trailer must have . . . . .	79
92	Operation of brakes on a heavy trailer . . . . .	79
93	Air or vacuum brakes on heavy trailers . . . . .	79
<b>Part 8</b>	<b>Control of emissions</b>	
<b>Division 1</b>	<b>Crank case gases and visible emissions</b>	
94	Crank case gases . . . . .	80
95	Visible emissions . . . . .	80
96	Exhaust emissions—diesel-powered vehicles . . . . .	81
97	Test procedure . . . . .	82
98	Requirements of DT80 test cycle . . . . .	84
<b>Division 2</b>	<b>Exhaust systems</b>	
99	Exhaust systems . . . . .	88
<b>Division 3</b>	<b>Noise emissions</b>	
<b>Subdivision 1</b>	<b>General</b>	
100	Measurement of stationary noise levels . . . . .	90
101	Meaning of certified to ADR 83/00 . . . . .	90
102	Silencing device for exhaust systems . . . . .	91

Contents

---

<b>Subdivision 2</b>	<b>Noise levels applying to vehicles not certified to ADR 83/00</b>	
103	Application of Sdiv 2. . . . .	91
104	Stationary noise levels—other vehicles with spark ignition engines . . . . .	91
105	Stationary noise levels—other vehicles with diesel engines . . . . .	91
<b>Subdivision 3</b>	<b>Noise levels applying to vehicles certified to ADR 83/00</b>	
106	Stationary noise levels . . . . .	93
<b>Part 8</b>	<b>Alternative fuel systems</b>	
107	LPG-powered vehicles . . . . .	93
108	Vehicles powered by natural gas . . . . .	94
<b>Part 9</b>	<b>Maximum road speed limiting</b>	
109	Speed limiting. . . . .	94
<b>Schedule 3</b>	<b>Vehicle standards applying only to heavy combinations or particular heavy combinations . . . . .</b>	<b>96</b>
<b>Part 1</b>	<b>Preliminary</b>	
1	References to combinations, B-doubles and road trains . . . . .	96
2	Application to vehicle complying with inconsistent ADR requirement . . . . .	96
3	Application of provision to heavy vehicle subject of Motor Vehicle Standards Act approval . . . . .	97
<b>Part 2</b>	<b>General safety requirements</b>	
4	Electrical wiring, connections and installations . . . . .	97
<b>Part 3</b>	<b>Vehicle marking</b>	
5	Warning signs for combinations longer than 22m . . . . .	97
6	Specifications for warning signs . . . . .	98
<b>Part 4</b>	<b>Braking systems</b>	
7	Application of Pt 4 to road trains . . . . .	100
8	Braking system design for a prime mover in a B-double . . . . .	100
9	Braking system design for heavy motor vehicles in road trains . . . . .	100
10	Braking system design for heavy trailers in B-doubles or road trains . . . . .	101
11	Air brakes of a heavy motor vehicle in B-doubles or road trains . . . . .	101
12	Air brakes in a B-double or road train—least favoured chamber . . . . .	102
13	Recovery of air pressure for brakes in B-doubles and road trains . . . . .	103
14	Air supply for air brakes in B-doubles and road trains . . . . .	104
15	Brake line couplings . . . . .	104
16	Simultaneous parking brake application. . . . .	104
17	Capacity of air reservoirs . . . . .	105

<b>Part 5</b>	<b>Mechanical connections between vehicles in combinations</b>	
<b>Division 1</b>	<b>Couplings used in all types of heavy combination</b>	
18	General coupling requirements . . . . .	105
19	Drawbar couplings . . . . .	106
<b>Division 2</b>	<b>Additional coupling requirements for B-doubles and long road trains</b>	
20	Application of Div 2 to road trains . . . . .	106
21	Couplings for B-doubles and road trains . . . . .	106
22	Selection of fifth wheel couplings and turntables for B-doubles and road trains . . . . .	107
23	Mounting of fifth wheel couplings on B-doubles and road trains . . . . .	108
24	Branding of fifth wheel couplings and turntables on B-doubles and road trains . . . . .	108
25	Selection of kingpins for B-doubles and road trains . . . . .	108
26	Attachment of kingpins on B-doubles and road trains . . . . .	110
27	Branding of kingpins on B-doubles and road trains . . . . .	110
28	Selection of couplings and drawbar eyes for road trains . . . . .	110
29	Attachment of couplings and drawbar eyes on road trains . . . . .	110
30	Branding of couplings and drawbar eyes on road trains . . . . .	111
31	Tow coupling overhang on road trains . . . . .	111

[s 1]

---

## **Part 1 Preliminary**

### **1 Short title**

This Regulation may be cited as the *Heavy Vehicle (Vehicle Standards) National Regulation*.

### **2 Commencement**

This Regulation commences in a participating jurisdiction on the day on which Chapter 3 of the Law commences in that jurisdiction.

*Note—*

In this Regulation, a reference to ‘the Law’ is a reference to the Heavy Vehicle National Law. See section 12(2) of Schedule 1 of the Heavy Vehicle National Law.

### **3 Prescription of vehicle standards**

- (1) This Regulation prescribes the vehicle standards with which a single heavy vehicle or heavy combination must comply for its use on a road.
- (2) The vehicle standards are set out in Schedules 1 to 3.
- (3) However, only Part 3 of Schedule 3 applies to a vehicle that is not a heavy vehicle but forms part of a combination that is a heavy combination.

*Note—*

The vehicle standards are based on the *Australian Vehicle Standards Rules 1999* contained in Schedule 2 of the *National Transport Commission (Road Transport Legislation—Vehicle Standards) Regulations 2006* of the Commonwealth.



---

## Part 2 Interpretation and provisions about application of vehicle standards

### 4 Definitions

In this Regulation—

**50mm kingpin** means a kingpin meeting the dimension requirements for a 50mm kingpin in AS 2175-1990 ‘Articulated Vehicles—Kingpins’.

*Note—*

AS 2175-1990 ‘Articulated Vehicles—Kingpins’ may be purchased from Standards Australia at <[www.standards.org.au](http://www.standards.org.au)>.

**75mm kingpin** means a kingpin with the dimensions mentioned in section 25(3) of Schedule 3.

**90mm kingpin** means a kingpin meeting the dimension requirements for a 90mm kingpin in AS 2175-1990 ‘Articulated Vehicles—Kingpins’.

*Note—*

AS 2175-1990 ‘Articulated Vehicles—Kingpins’ may be purchased from Standards Australia at <[www.standards.org.au](http://www.standards.org.au)>.

**air brake** means an air-operated or air-assisted brake.

**air brake compressor**, in relation to a vehicle, means a compressor for supplying air to the vehicle’s air brakes.

**air brake reservoir**, in relation to a vehicle, means a device for storing compressed air for the purpose of supply to the vehicle’s braking system.

**air storage tank**, in relation to a vehicle, means a tank fitted to the vehicle for storing compressed air.

**American National Standard** means a standard published by the American National Standards Institute.

**American National Standards Institute** means the not-for-profit organisation of that name comprising government agencies of the United States of America,

[s 4]

---

organisations, companies, academic and international bodies, and individuals.

**AS/NZS** means a standard jointly made or published by Standards Australia and Standards New Zealand.

**Australian Standard** means—

- (a) a standard made or published by Standards Australia; or
- (b) a standard jointly made or published by Standards Australia and Standards New Zealand.

*Note—*

Copies of Australian Standards may be purchased from Standards Australia at <[www.standards.org.au](http://www.standards.org.au)>.

**braking system**, of a vehicle, means the system comprising all the brakes of the vehicle and all the components of the mechanisms by which they are operated.

**British Standard** means a standard approved for publication on behalf of the British Standards Institution.

*Note—*

Copies of British Standards may be purchased from Standards Australia at <[www.standards.org.au](http://www.standards.org.au)>.

**British Standards Institution** means the institution of that name established under royal charter in the United Kingdom.

**centre**, of an axle group, means—

- (a) a vertical line located midway between the centre-lines of the outermost axles of the group; or
- (b) if there are 2 axles in the group and 1 of them is fitted with twice the number of tyres as the other axle—a vertical line located one-third of the way from the centre-line of the axle with more tyres towards the centre-line of the axle with fewer tyres.

*Examples—*

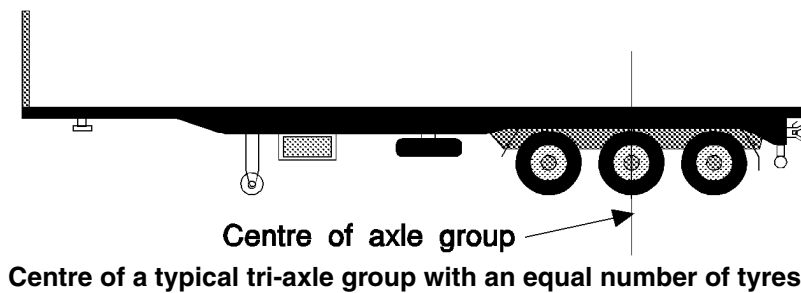
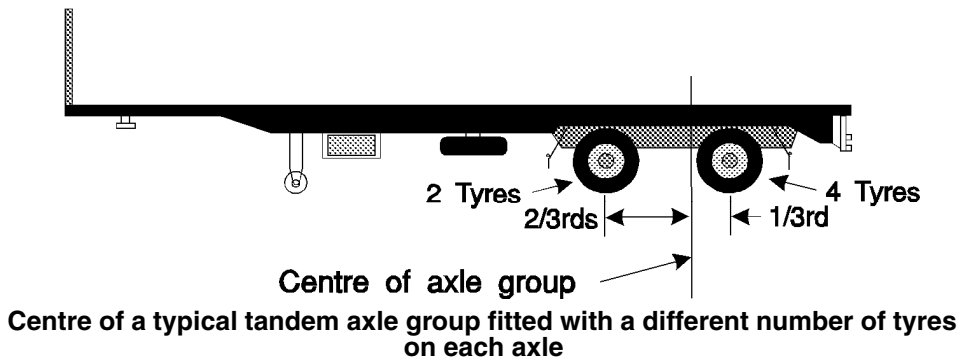
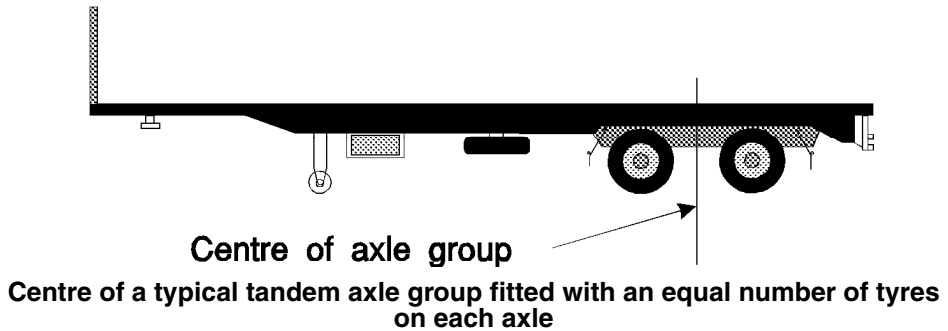

[s 4]

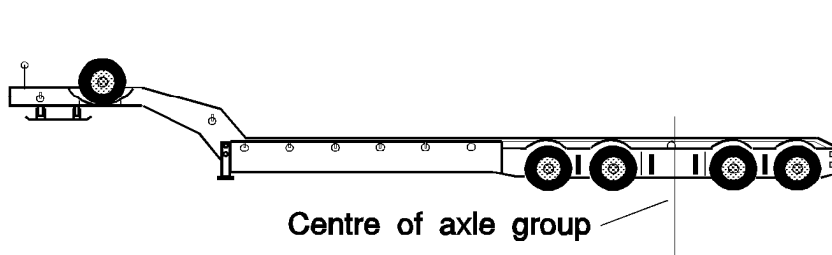

**Centre of a typical quad-axle group with an equal number of tyres**

*dangerous goods*, in relation to a participating jurisdiction, has the meaning given by the laws of the jurisdiction relating to the transport of dangerous goods.

*diesel engine* means an engine that works on the compression-ignition principle, commonly known as a diesel engine.

*dog trailer* means a trailer (including a trailer consisting of a semitrailer and converter dolly) that has—

- (a) 1 axle group or a single axle at the front that is being steered by connection to a towing vehicle by a drawbar; and
- (b) 1 axle group or a single axle at the rear.

*Example—*

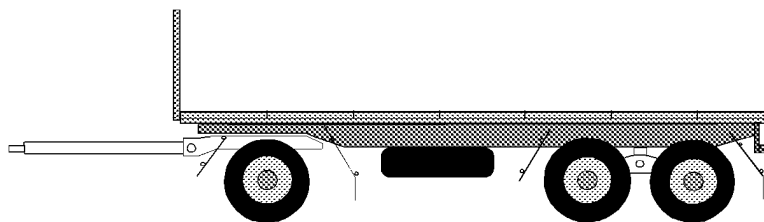

**Dog trailer**

*drawbar* means a part of a trailer (other than a semitrailer) that connects the trailer body to a coupling for towing purposes.

*drawbar eye* means the part of a coupling fitted to a trailer's drawbar through which a pintle hook or pin on a towing vehicle is passed.

---

***drawbar-type coupling*** means a coupling fitted to a trailer used to connect the trailer's drawbar to a towing vehicle.

***emergency brake***, in relation to a vehicle, means a brake designed to be used if the vehicle's service brake fails.

***emergency service*** means an entity that has a statutory responsibility to respond to an emergency and includes the following—

- (a) an ambulance service;
- (b) a fire brigade, including a volunteer fire brigade;
- (c) a police service or police force;
- (d) a disaster or emergency organisation of the Commonwealth or a State or Territory.

***emergency vehicle*** means a heavy vehicle—

- (a) fitted with—
  - (i) a repeater horn or siren; or
  - (ii) a flashing warning light; and
- (b) driven by an officer of an emergency service in the course of the officer's duty.

***exempt vehicle*** means any of the following heavy vehicles—

- (a) an emergency vehicle;
- (b) a police vehicle;
- (c) a road enforcement vehicle;
- (d) a heavy vehicle driven by an officer of the Australian Customs Service or Airservices Australia in the course of the officer's duty.

***exhibition purpose***, in relation to a heavy vehicle, means the display of the vehicle, or the demonstration of the vehicle's operation—

- (a) at community events; or
- (b) to community groups.

[s 4]

---

***former Australian Transport Council*** means the former Australian Transport Council comprising Commonwealth, State and Territory Ministers responsible for transport and road issues.

***front fog light*** means a light used to improve the illumination of the road in case of fog, snowfall, heavy rain or a dust storm.

***GTM*** (gross trailer mass), of a trailer, means the mass transmitted to the ground by the axles of the trailer when it is loaded to its GVM and connected to a towing vehicle.

***high-beam***, in relation to a headlight, means the light is built or adjusted so that, when the vehicle is standing on level ground, the top of the main beam of light projected is above the low-beam position.

***Japanese Industrial Standard*** means a standard published by the Japanese Standards Association.

***Japanese Standards Association*** means the organisation of that name incorporated in Japan.

***left***, in relation to a vehicle, means left of the centre of the vehicle when viewed by a person in the vehicle who is facing the front of the vehicle.

***low-beam***, in relation to a headlight or front fog light fitted to a heavy vehicle, means the light is built or adjusted so that, when the vehicle is standing on level ground, the top of the main beam of light projected is—

- (a) not higher than the centre of the headlight or fog light, when measured 8m in front of the vehicle; and
- (b) not more than 1m higher than the level where the vehicle is standing, when measured 25m in front of the vehicle.

***Motor Vehicle Standards Act*** means the *Motor Vehicle Standards Act 1989* of the Commonwealth.

***parking brake***, in relation to a vehicle, means the brake usually used to keep a vehicle stationary while the vehicle is parked.

***police vehicle*** means a heavy vehicle driven by a police officer in the course of the police officer's duty.

***prescribed dimension requirements*** means the prescribed dimension requirements under the *Heavy Vehicle (Mass, Dimension and Loading) National Regulation*.

***repeater horn*** means a device that makes a sound alternating between different tones or frequencies on a regular time cycle.

***right***, in relation to a vehicle, means right of the centre of the vehicle when viewed by a person in the vehicle who is facing the front of the vehicle.

***road enforcement vehicle*** means a heavy motor vehicle marked as a vehicle of a road authority for a participating jurisdiction and used by the authority for the purpose of investigating or prosecuting an offence against an Australian road law.

***road tank vehicle*** has the meaning given by the 'Australian Code for the Transport of Dangerous Goods by Road and Rail', seventh edition, approved by the former Australian Transport Council.

***second edition ADR*** means the ADR incorporated in the document described as the 'Australian Design Rules for Motor Vehicle Safety, Second Edition' originally published by the former Commonwealth Department of Transport.

***service brake***, in relation to a vehicle, means the brake usually used to decelerate the vehicle.

***side marker light*** means a light fitted to the side of a vehicle indicating the presence and length of the vehicle when viewed on that side.

***single heavy vehicle*** means a motor vehicle or trailer that, on its own, is a heavy vehicle.

***Standards Association of Australia***, for anything done or to be done on or after 1 July 1999, includes a reference to Standards Australia Limited ACN 087 326 690.

[s 5]

---

***Standards New Zealand*** means the trading entity of the Standards Council continued in existence under the *Standards Act 1988* of New Zealand.

***third edition ADR*** means the ADR incorporated in the document described as the ‘Australian Design Rules for Motor Vehicles and Trailers, Third Edition’ published by the former Federal Office of Road Safety of the Commonwealth Department of Transport and Regional Development.

***towing vehicle***, in relation to a trailer, means the vehicle towing the trailer.

***turntable*** means a bearing built to carry vertical and horizontal loads, but that does not allow quick separation of its upper and lower rotating elements, and is used to connect and allow articulation between—

- (a) a prime mover and a semitrailer; or
- (b) the front axle group or axle of a dog trailer and the body of the trailer; or
- (c) a fifth wheel coupling and the vehicle to which it is mounted.

***vacuum brake*** means a vacuum-operated brake or a vacuum-assisted brake.

***vacuum storage tank***, in relation to a vehicle, means a tank fitted to the vehicle for storing air at a low pressure.

***warning light*** means a light fitted to a vehicle designed for the specific purpose of warning road users of the vehicle’s presence on a road.

***wheel chock*** means a device fitted to 1 or more wheels of a vehicle to prevent the vehicle moving while it is parked.

***yellow***, in relation to a light, includes amber.

## **5 References to vehicle include its equipment etc.**

In this Regulation, a reference to a vehicle is taken to include a reference to the vehicle and all of the equipment fitted to, or forming part of, the vehicle.



---

## **6 References to heavy vehicles are references to single heavy vehicles**

In this Regulation, a reference to a heavy vehicle is taken to be a reference to a single heavy vehicle.

## **7 When restored vehicle is built**

(1) For the purposes of this Regulation, a restored vehicle is taken to have been built when it was originally built and not when it was restored.

(2) In this section—

*restored vehicle* means a vehicle that is being, or has been, restored to its manufacturer's specifications, so far as it is practicable to meet the specifications.

## **8 Measurement of width of vehicles**

When measuring the width of a heavy vehicle for a provision of this Regulation, any of the following items that may be fitted to the vehicle are to be disregarded—

- (a) anti-skid devices mounted on wheels;
- (b) central tyre inflation systems;
- (c) lights, mirrors, reflectors, signalling devices or tyre pressure gauges.

## **9 Interpretation of particular second edition ADRs**

(1) This section applies to a left-hand drive heavy motor vehicle.

(2) In applying the following second edition ADRs to the heavy motor vehicle, the words 'left' and 'right' have the opposite meaning—

- ADR 8 Safety Glass
- ADR 12 Glare Reduction in Field of View
- ADR 14 Rear Vision Mirrors

[s 10]

---

- ADR 16 Windscreen Wipers and Washers
- ADRs 18 and 18A Location and Visibility of Instruments
- ADRs 35 and 35A Commercial Vehicle Braking Systems.

## 10 Compliance with particular standards

- (1) This section applies if—
  - (a) a provision of this Regulation requires a vehicle or a component of a vehicle to comply with a prescribed standard (the *superseded standard*); and
  - (b) the prescribed standard has been superseded by a later prescribed standard (the *later standard*).
- (2) The vehicle or component is taken to comply with the superseded standard if it complies with the later standard.
- (3) In this section—

*prescribed standard* means—

  - (a) an Australian Standard; or
  - (b) a British Standard; or
  - (c) an American National Standard; or
  - (d) a Japanese Industrial Standard.

## 11 Compliance with requirement to have particular equipment

A vehicle is taken to have equipment mentioned in this Regulation only if the equipment is in working order.

## 12 Modifications

The prescribed code of practice for the purposes of section 86 and 87 of the Law is the NHVR Code of Practice for the Approval of Heavy Vehicle Modifications.

---

## **Schedule 1      Vehicle standards relating to ADR's applying to single heavy vehicles**

section 3

### **Part 1                      Compliance with ADRs**

#### **1                      Second edition ADRs**

- (1) If a second edition ADR recommends that the ADR should apply to a heavy vehicle, the vehicle must comply with the ADR.
- (2) If a second edition ADR has a requirement for a type of equipment fitted to a heavy vehicle built on or after a stated time, any equipment of the same type fitted to the vehicle after it is built must comply with—
  - (a) the requirement as in force when the vehicle was built; or
  - (b) if the requirement is amended after the vehicle is built and before the equipment is fitted, the requirement as in force at any time between—
    - (i) when the vehicle was built; and
    - (ii) when the equipment was fitted.
- (3) However, a vehicle, or equipment fitted to a vehicle, need not comply with a recommendation or requirement of a second edition ADR if—
  - (a) the recommendation or requirement is replaced by, or is inconsistent with, a requirement of a third edition ADR applying to the vehicle or equipment; and
  - (b) the vehicle or equipment complies with the requirement of the third edition ADR.

- (4) If a second edition ADR allows a vehicle built on or after a stated time to be fitted with equipment, a vehicle built before the time may also be fitted with the equipment.
- (5) This section is subject to any provision of Schedule 2 or 3 expressly providing for the application of stated requirements of a second edition ADR.

## **2 Third edition ADRs**

- (1) If a third edition ADR applies to the design and construction of a heavy vehicle, the vehicle must comply with the ADR.
- (2) If a third edition ADR contains a requirement for a type of equipment fitted to a heavy vehicle built on or after a stated time, any equipment of the same type fitted to the vehicle after it is built must comply with—
  - (a) the requirement as in force when the vehicle was built; or
  - (b) if the requirement is amended after the vehicle is built and before the equipment is fitted, the requirement as in force at any time between—
    - (i) when the vehicle was built; and
    - (ii) when the equipment was fitted.
- (3) However, a vehicle, or equipment fitted to a vehicle, need not comply with a requirement of a third edition ADR if—
  - (a) the requirement is replaced by, or is inconsistent with, a requirement of a later version of the ADR applying to the vehicle or equipment; and
  - (b) the vehicle or equipment complies with the requirement of the later version.
- (4) If a third edition ADR allows a vehicle built on or after a stated time to be fitted with equipment, a vehicle built before the time may also be fitted with the equipment.
- (5) This section is subject to any provision of Schedule 2 or 3 expressly providing for the application of stated requirements of a third edition ADR.



## 5 Partial exemption for personally imported vehicles

- (1) A personally imported vehicle must be fitted with—
  - (a) seatbelts as effective as seatbelts meeting an Australian Standard or British Standard for seatbelts as in force when the vehicle is imported; and
  - (b) seatbelt anchorages meeting the number and location requirements of third edition ADR 5; and
  - (c) child restraint anchorages meeting the number, location, accessibility, thread size and form requirements of second edition ADR 34 or third edition ADR 5 or 34.
- (2) However, a personally imported vehicle need only meet the requirements of an ADR mentioned in subsection (1) if the ADR recommends that it should apply, or applies, to a vehicle of the same type.
- (3) A personally imported vehicle need not otherwise comply with an ADR applied by section 1(1) or 2(1).

- (4) In this section—

***personally imported vehicle*** means a vehicle built after 1968 imported into Australia by a person who—

- (a) before the vehicle was imported into Australia, owned and used it for a continuous period of at least—
  - (i) for a vehicle owned by the person before 9 May 2000—3 months; or
  - (ii) in any other case—1 year; and
- (b) when the vehicle was imported into Australia, was—
  - (i) an Australian citizen, permanent resident or a person who had applied to become an Australian citizen or permanent resident; and
  - (ii) old enough to hold a driver's licence or learner's permit to drive the vehicle; and
- (c) has undertaken to comply with any requirements relating to road safety imposed for the vehicle under the *Motor Vehicle Standards Regulations 1989* of the Commonwealth; and

- (d) within the previous year, has not imported into Australia another vehicle owned by the person.

## **Schedule 2      Other vehicle standards applying to single heavy vehicles**

section 3

### **Part 1                      Preliminary**

#### **1                      References to particular trailers are to heavy trailers of that type**

In this Schedule—

- (a) a reference to a pole-type trailer is taken to be a reference to a pole-type trailer that is a heavy vehicle; and
- (b) a reference to a semitrailer is taken to be a reference to a semitrailer that is a heavy vehicle.

#### **2                      Application to heavy vehicle complying with inconsistent ADR requirement**

- (1) A provision of this Schedule does not apply to a heavy vehicle if the provision is inconsistent with a requirement of a second or third edition ADR that the vehicle complies with, regardless of whether or not the vehicle is required to comply with the requirement.
- (2) However, subsection (1) does not apply if the heavy vehicle is not of the same class or type as a vehicle to which the requirement of the second or third edition ADR applies.
- (3) Also, to avoid doubt, this section does not apply to a requirement of a second or third edition ADR if, and to the extent, a provision of this Schedule expressly provides that the requirement does not apply to a stated heavy vehicle, a heavy vehicle of a stated type or in stated circumstances.



### **3 Application to heavy vehicle subject of Motor Vehicle Standards Act approval**

A provision of this Schedule does not apply to a heavy vehicle if—

- (a) the vehicle does not comply with a requirement of an ADR applying to the vehicle; and
- (b) the provision corresponds to the requirement of the ADR; and
- (c) despite the noncompliance, approval has been given under section 10A(2) or (3) of the Motor Vehicle Standards Act to place identification plates on vehicles of that type; and
- (d) the vehicle complies with the approval conditions, if any.

## **Part 2 General safety requirements**

### **4 Steering**

- (1) A heavy motor vehicle must have a right-hand drive.
- (2) A heavy motor vehicle has a right-hand drive if the centre of at least 1 steering control of the vehicle is to the right of the vehicle or in line with the centre of the vehicle.
- (3) A component of a steering system of a heavy motor vehicle that is essential for effective steering of the vehicle must be built to transmit energy by mechanical means only.
- (4) Failure of a non-mechanical component of a heavy motor vehicle's steering system must not prevent effective steering of the vehicle.
- (5) This section does not apply to a heavy motor vehicle if the vehicle is built mainly for a purpose other than the transport of goods or passengers by road.

## **5 Turning ability**

- (1) A heavy motor vehicle must be able to turn in a circle not more than 25m in diameter, measured by the outer edge of the tyre track at ground level.
- (2) A heavy motor vehicle must be able to comply with subsection (1) whether it turns to the left or to the right.

## **6 Ability to travel backwards and forwards**

A heavy motor vehicle must be able to be driven both backwards and forwards when the vehicle's driver is in the normal driving position.

## **7 Protrusions**

- (1) A thing fitted to a heavy vehicle must be designed, built and fitted to the vehicle in a way that minimises the likelihood of injury to a person making contact with the vehicle.
- (2) However, subsection (1) does not apply to a thing fitted to a heavy vehicle if—
  - (a) the vehicle was designed before 1965 and the thing was part of the vehicle's design; or
  - (b) the thing was fitted to the vehicle before 1965 in accordance with the law of the place where the thing was fitted.

## **8 Driver's view and vehicle controls**

A heavy motor vehicle must be built—

- (a) to allow the driver in the normal driving position a view of the road and of traffic to the front and sides of the vehicle so the driver can drive the vehicle safely; and
- (b) with its controls located so the driver can drive the vehicle safely.

---

**9 Seating**

A seat for a driver or passenger in a heavy vehicle must be securely attached to the vehicle.

**10 Mudguards**

- (1) A heavy vehicle must have a mudguard firmly fitted for each wheel or for adjacent wheels.
- (2) However, subsection (1) does not apply to a heavy vehicle if—
  - (a) the construction or use of the vehicle makes the fitting of mudguards unnecessary or impracticable; or
  - (b) the body or part of the body of the vehicle acts as a mudguard.

*Examples for subsection (2)(a)—*

- pole-type trailers used to carry timber
  - most road-making plant
  - some agricultural equipment
- (3) A mudguard fitted to a heavy vehicle must, when the vehicle's wheels are in position to move straight ahead—
    - (a) reduce the danger of a person contacting the moving wheels; and
    - (b) for the rear wheels—
      - (i) cover the overall width of the wheel or wheels to which it is fitted; and
      - (ii) be fitted so the height above ground level of the lowest edge of the rear of the mudguard is not more than one-third of the horizontal distance between the edge and the centre of the rearmost axle.
  - (4) However, a mudguard fitted to a heavy vehicle may be up to—
    - (a) 230mm above ground level; or

- (b) if the vehicle is built to be used off-road—300mm above ground level.
- (5) The outside of a rear mudguard, other than a mudflap, of a heavy vehicle that can be seen from the rear of the vehicle must be coloured white or silver if the vehicle—
  - (a) is at least 2.2m wide; and
  - (b) has a body the vertical measurement of which is less than 300mm at the rear, measured from the lowest point of the body above ground level to the highest point; and
  - (c) is not fitted with rear marking plates in accordance with section 80.
- (6) In this section—

*mudguard* means a fitting or device, with or without a mudflap, built and fitted to a heavy vehicle in a way that will, as far as practicable, catch or deflect downwards any stone, mud, water, or other substance, thrown up by the rotation of the wheel of the vehicle to which the fitting or device is fitted.

## 11 Horns, alarms etc.

- (1) A heavy motor vehicle must be fitted with at least 1 horn or other device that can give sufficient audible warning to other road users of the approach or position of the vehicle.
- (2) A heavy motor vehicle must not be fitted with a device that can make a sound like the sound of a siren, exhaust whistle, compression whistle or repeater horn.
- (3) However, subsection (2) does not apply to the following—
  - (a) an exempt vehicle;
  - (b) a heavy vehicle at least 25 years old and fitted as an emergency vehicle or police vehicle if the vehicle—
    - (i) is used only for exhibition purposes; or
    - (ii) is part of a collection of former emergency vehicles or police vehicles;
  - (c) an anti-theft alarm fitted to a heavy vehicle that can not be operated while the vehicle's ignition is on.

- 
- (4) Also, a heavy motor vehicle may be fitted with a device that—
    - (a) emits a regular, intermittent sound while the vehicle is reversing or in reverse gear; and
    - (b) is not louder than is necessary so the driver, and a person near the vehicle, can hear the device when it is operating.
  - (5) The provision of the relevant ADR that corresponds to subsection (2) applies to a vehicle as if that provision did not contain a reference to a bell.

*Note—*

For the relevant ADR, see the *Vehicle Standard (Australian Design Rule 42/04—General Safety Requirements) 2005*, subrule 20.1.1.

## **12 Rear vision mirrors**

- (1) At least 1 rear vision mirror must be fitted to each side of a heavy motor vehicle.
- (2) A rear vision mirror fitted to a heavy motor vehicle as required by subsection (1) must be fitted so that the vehicle's driver in the normal driving position can clearly see by reflection the road behind the vehicle and any following or overtaking vehicle.
- (3) A rear vision mirror fitted to a heavy motor vehicle as required by subsection (1) must not project beyond the external bodywork of a heavy vehicle substantially more than is necessary for it to provide adequate rearward vision.
- (4) If the lower edge of an exterior rear vision mirror fitted to a heavy motor vehicle as required by subsection (1) is less than 2m above the ground when the vehicle is loaded to maximum mass permitted for the vehicle, the mirror must not project more than 250mm beyond the overall width of the vehicle, measured in accordance with the prescribed dimension requirements applying to the vehicle.
- (5) A rear vision mirror fitted to a heavy motor vehicle as required by subsection (1) must have a reflecting surface of at least 150cm<sup>2</sup>.

### **13 Additional rear vision mirrors and mirror surfaces**

- (1) A heavy motor vehicle may be fitted with additional rear vision mirrors or with mirror surfaces.
- (2) Additional rear vision mirrors fitted to a heavy motor vehicle must have a flat or convex surface, or a combination of flat and convex surfaces.
- (3) Mirror surfaces fitted to a heavy motor vehicle must be flat or convex, or both flat and convex.
- (4) In this section—

*mirror surface* means a thing with a mirror that may be fitted to a vehicle to perform a similar function to a rear vision mirror.

### **14 Automatic transmission**

- (1) A heavy motor vehicle fitted with an automatic transmission must have an engine starter mechanism that can not operate when the transmission control is in a position to drive the vehicle.
- (2) A heavy motor vehicle built after 1975 that is fitted with an automatic transmission must have an indicator in the driver's compartment showing the transmission control position.
- (3) Subsections (1) and (2) do not apply to a heavy motor vehicle with fewer than 4 wheels.

### **15 Diesel engines**

A heavy motor vehicle propelled by a diesel engine must be fitted with a device preventing the engine from being started accidentally or inadvertently.

### **16 Bonnet-securing devices**

- (1) A heavy motor vehicle with a moveable body panel forward of the windscreen covering an engine or luggage storage or battery compartment must have a device to secure the panel.

- 
- (2) However, if the panel opens from the front in a way partly or completely obstructing the driver's forward view through the windscreen, the panel must have primary and secondary devices to secure the panel.

## 17 Electrical wiring, connectors and conductors

- (1) The wiring of electrical equipment of a heavy vehicle, other than the high tension ignition wiring, must—
- (a) be supported at intervals of not more than 600mm, unless the vehicle is a pole-type trailer with a pole with an adjustable length or is an extendible trailer; and
  - (b) be insulated at each of its joints; and
  - (c) be located where it can not—
    - (i) become overheated; or
    - (ii) contact moving parts; or
    - (iii) come near enough to the fuel system to be a fire hazard; and
  - (d) be protected from chafing.
- (2) The electrical components of a vehicle must be securely mounted.
- (3) The electrical connectors between a heavy motor vehicle and trailer, for operation of the vehicle lights required by this Regulation, must comply with at least 1 of the following—
- AS 2513-1982 Electrical Connectors for Trailer Vehicles
- Note—*
- AS 2513-1982 'Electrical Connectors for Trailer Vehicles' may be purchased from Standards Australia at <[www.standards.org.au](http://www.standards.org.au)>.
  - International Standards Organisation ISO 1185—1997
  - Society of Automotive Engineers SAE J 560—1998
  - AS 4735-2003 Heavy road vehicles—Electrical connectors for articulated vehicles.

- (4) A heavy trailer must be equipped with an electrical conductor, independent of the trailer coupling fitted to the trailer, that makes a return path between the electrical circuits of the trailer and towing vehicle.

- (5) In this section—

*electrical connector* means a device intended for making a detachable electrical connection between a motor vehicle and a trailer.

*high tension ignition wiring*, for a vehicle, means wiring designed to transmit electrical currents for the purpose of igniting fuel in the vehicle's engine.

## 18 Television receivers and visual display units

- (1) A television receiver or visual display unit must not be installed in a heavy vehicle so any part of the image on the screen is visible to the vehicle's driver from the normal driving position.

- (2) However, subsection (1) does not apply to—

- (a) a television receiver or visual display unit that can not be operated when the heavy vehicle is moving; or
- (b) a driver's aid in the heavy vehicle or, if the heavy vehicle is a bus, a destination sign in the bus.

*Examples for paragraph (b)—*

- closed-circuit television security cameras
- dispatch systems
- navigational or intelligent highway and vehicle system equipment
- rear view screens
- ticket-issuing machines
- vehicle-monitoring devices

- (3) A television receiver, or visual display unit, and its associated equipment in a heavy vehicle must be securely mounted in a position that does not—



- 
- (a) obscure the driver's view of the road from the normal driving position; or
  - (b) impede the movement of a person in the vehicle.

## 19 Requirement for windscreen to be fitted

A heavy motor vehicle must be fitted with a windscreen if it is manufactured or designed to have a windscreen.

## 20 Windscreens and windows

- (1) Transparent material used in a windscreen, window or an interior partition of a heavy motor vehicle must be of approved material if—
  - (a) the vehicle was built after June 1953; or
  - (b) the material was first fitted to the vehicle after June 1953.
- (2) Subsection (1) does not apply to any coating added to the windscreen, window or partition after its manufacture.
- (3) In this section—

*approved material* means material with the same characteristics as material mentioned in any of the following standards—

- AS R1-1965 'Safety Glass for Land Transport'
- AS R1-1968 'Safety Glass for Land Transport'
- AS 2080-1977 'Safety Glass for Vehicles'
- British Standard BS 857:1967 'Specification for Safety Glass for Land Transport'
- British Standard BS 5282:1975 'Specification for Road Vehicle Safety Glass'
- British Standard BS AU 178:1980 'Specification for Road Vehicle Safety Glass'
- Japanese Industrial Standard JIS R 3211-1979 'Safety Glasses for Road Vehicles'

- American National Standard ANSI Z26.1-1980 ‘Safety Code for Safety Glazing Materials for Glazing Motor Vehicles Operating on Land Highway’.

## 21 Window tinting

- (1) Glazing used in a windscreen of a heavy motor vehicle must have a luminous transmittance of at least 70%.
- (2) Glazing used in a windscreen of a heavy motor vehicle must not be coated in a way that reduces its luminous transmittance.
- (3) However, subsections (1) and (2) do not apply to the greater of the following areas of a windscreen—
  - (a) the area above the highest point of the windscreen that is swept by a windscreen wiper;
  - (b) the upper 10% of the windscreen.
- (4) Glazing used in a window or interior partition of a heavy motor vehicle may be coated to achieve a luminous transmittance of not less than 35%.
- (5) The requirements about luminous transmittance applying to glazing used in a window of a heavy motor vehicle stated in a second edition ADR or third edition ADR do not apply to a window that has been coated as provided in subsection (4).
- (6) Glazing used in a windscreen, window or interior partition of a heavy motor vehicle that has been coated to reduce its luminous transmittance must not have a reflectance of more than 10%.
- (7) In this section—

**glazing**—

  - (a) means material that may be used in a windscreen, window or interior partition of a heavy motor vehicle, through which the vehicle’s driver can see the road; but
  - (b) does not include a coating added after manufacture of the material.

---

*luminous transmittance*, for glazing, means the amount of light that can pass through the glazing as a percentage of the amount of light that would be transmitted if the glazing were absent.

## 22 Windscreen wipers and washers

- (1) A heavy motor vehicle with 3 or more wheels fitted with a windscreen must be fitted with at least 1 windscreen wiper unless the vehicle's driver in the normal driving position can obtain an adequate view of the road ahead of the vehicle without looking through the windscreen.
- (2) At least 1 windscreen wiper fitted to a heavy motor vehicle mentioned in subsection (1) must—
  - (a) be able to remove moisture from the part of the windscreen in front of the driver in the normal driving position to allow the driver an adequate view of the road ahead of the vehicle when the windscreen is wet; and
  - (b) be able to be operated from the normal driving position; and
  - (c) for a vehicle built after 1934—continue to operate until the wiper is switched off; and
  - (d) for a vehicle built after 1959, the normal driving position of which is nearer 1 side of the vehicle than the other—
    - (i) be able to remove moisture from the part of the windscreen in front of the driver in the normal driving position, and a corresponding part of the windscreen on the other side of the centre of the vehicle, to allow the driver an adequate view of the road ahead of the vehicle when the windscreen is wet; and
    - (ii) if the windscreen wiper is operated by engine manifold vacuum—be connected to a vacuum reservoir or vacuum pump to maintain the efficient operation of the wiper while the vehicle is in motion.

- (3) If a heavy motor vehicle mentioned in subsection (1) was built after 1982, it must also be fitted with a windscreen washer that—
- (a) can direct water onto the windscreen within the area swept by a windscreen wiper so the wiper can spread the water to all of the area swept by the wiper; and
  - (b) is able to be operated from the normal driving position.
- (4) In this section—

*engine manifold vacuum*, in relation to a vehicle, means low air pressure in the vehicle's engine produced by inducting air, or a mix of air and fuel, into the vehicle's engine.

*vacuum pump* means a pump fitted to a vehicle that generates low air pressure to help the mechanical functioning of other equipment fitted to the vehicle.

*vacuum reservoir*, in relation to a vehicle, means a device designed to store air at a low pressure to help the mechanical functioning of other equipment fitted to the vehicle.

## **23 Wheels and tyres—size and capacity**

- (1) The wheels and tyres fitted to an axle of a heavy vehicle must be of sufficient size and capacity to carry the part of the vehicle's gross mass transmitted to the ground through the axle.
- (2) For the purposes of subsection (1), the size and capacity of a pneumatic tyre fitted to an axle of a heavy vehicle must be determined at a cold inflation pressure of not more than the lesser of the following—
- (a) the pressure recommended by the tyre manufacturer;
  - (b) a pressure of—
    - (i) for a radial ply tyre—825kPa; or
    - (ii) for another tyre—700kPa.
- (3) In this section—

---

**ADR (Definitions and Vehicle Categories)** means the ADR titled ‘Vehicle Standard (Australian Design Rule—Definitions and Vehicle Categories) 2005’.

**radial ply tyre** means a radial ply tyre within the meaning of ADR (Definitions and Vehicle Categories).

## **24 Pneumatic tyres for particular heavy vehicles**

A heavy vehicle built after 1932 must be fitted with pneumatic tyres.

## **25 Tyres—defects**

A tyre fitted to a heavy vehicle must be free of any apparent defect that could make the vehicle unsafe.

## **26 Tyres—suitability**

- (1) The requirements about the suitability of a tyre fitted to a vehicle by reference to the vehicle’s speed stated in a second edition ADR or third edition ADR do not apply to a tyre fitted to a heavy vehicle.
- (2) A tyre fitted to a heavy vehicle must be suitable for road use at the lesser of—
  - (a) 100 km/h; and
  - (b) the vehicle’s top speed.

## **27 Retreads**

A tyre that is retreaded must not be fitted on a heavy vehicle if—

- (a) AS 1973-1993 ‘Pneumatic Tyres—Passenger Car, Light Truck and Truck/Bus—Retreading and Repair Processes’ applies to the tyre; and
- (b) the tyre was not retreaded in accordance with the standard.

## **28 Tyre tread**

- (1) A tyre fitted to a heavy motor vehicle must not have cleats or other gripping devices that could damage road surfaces.
- (2) A tyre fitted to the vehicle must have a tread pattern at least 1.5mm deep, other than at tread wear indicators, in a band running continuously—
  - (a) across at least 75% of the tyre width that normally comes into contact with the road; and
  - (b) around the whole circumference of the tyre.
- (3) A heavy vehicle must not be fitted with a tyre that has been treated by recutting or regrooving the tread rubber, unless the tyre was—
  - (a) constructed with an extra thickness of rubber designed for recutting or regrooving; and
  - (b) labelled to indicate the construction.
- (4) In this section—

*tread wear indicator*, in relation to a tyre, means a marking that indicates the limit of wear on the tyre.

## **Part 3 Vehicle marking**

### **29 Vehicle and engine identification numbers**

- (1) The engine of a heavy motor vehicle must have an individual engine identification number clearly stamped, embossed or otherwise permanently marked—
  - (a) if the engine was built after 1930—on the vehicle's engine block or main component; or
  - (b) otherwise—anywhere on the engine.
- (2) A heavy vehicle must have an individual vehicle identification number clearly stamped, embossed or otherwise

permanently marked on a substantial part of its frame or chassis.

- (3) A heavy vehicle's engine or vehicle identification number must be located where a person can read it easily without having to use tools to remove a part of the vehicle that would otherwise obstruct the person's view.
- (4) A heavy vehicle's engine or vehicle identification number may consist of numbers or a combination of numbers and letters.

### **30 White or silver band on particular vehicles**

- (1) This section applies to a heavy vehicle that—
  - (a) is at least 2.2m wide; and
  - (b) has a body with a vertical measurement less than 300mm at the rear, measured from the lowest point of the body above ground level to the highest point; and
  - (c) is not fitted with rear marking plates in accordance with section 80.
- (2) The heavy vehicle must have a white or silver band at least 75mm high across the full width of the rearmost part of the vehicle's body.

### **31 Left-hand drive signs**

- (1) This section applies to a heavy motor vehicle that has the centre of a steering control to the left of the vehicle.
- (2) The heavy motor vehicle must display the words 'left hand drive' on the rear of the vehicle.
- (3) The words must be in letters at least 75mm high, and in a colour contrasting with the background to the words.





- (i) can securely fix the extendible part or sliding axles to the rest of the vehicle in any position of adjustment provided; and
  - (ii) is located in a position that can prevent accidental or inadvertent release, if the device is mounted on the vehicle's chassis; and
  - (iii) is fitted with an audible or visible warning system to indicate to a person standing beside the vehicle that the device is not engaged; and
  - (iv) is fitted with a way of preventing loss of air from the air brake supply, if the device uses air from the semitrailer's braking system and fails in a way allowing air to escape; and
  - (v) is held in the applied position by direct mechanical action without the intervention of an electric, hydraulic or pneumatic device; and
- (b) be built so the adjustable parts of the vehicle remain connected if the securing device fails.

### **33 Relation between axles in axle group**

- (1) The axles in an axle group, other than a twinsteer axle group, fitted to a heavy vehicle must relate to each other through a load-sharing suspension system.

- (2) In this section—

*load-sharing suspension system*, of an axle group, has the same meaning as it has under the *Heavy Vehicle (Mass, Dimension and Loading) National Regulation*.

## **Part 5**                      **Dimension requirements**

### **34**      **Application of prescribed dimension requirements as a vehicle standard**

- (1) The dimensions of a heavy vehicle must comply with the prescribed dimension requirements (the *requirements*) applying to the vehicle.
- (2) The dimensions of a vehicle do not contravene subsection (1) in relation to a contravention of the requirements caused only by the load the vehicle is carrying.
- (3) If a vehicle has a retractable axle, the vehicle must comply with subsection (1) at any time with both the axle retracted and not retracted.

- (4) In this section—

*retracted*, in relation to an axle, has the same meaning as it has in section 5 of the *Heavy Vehicle (Mass, Dimension and Loading) National Regulation*.

## **Part 6**                      **Lights and reflectors**

### **Division 1**                **Application of particular requirements**

#### **35**      **Part does not apply to particular vehicles**

- (1) This Part does not apply to a heavy vehicle built before 1931 used only in the daytime.
- (2) This Part does not apply to a heavy vehicle built before 1946 used mainly for exhibition purposes.

**36 Particular requirements apply only at night**

The requirements of this Part for a light, other than a brake or direction indicator light, to be visible over a stated distance apply only at night.

**Division 2 General requirements for lights****37 Prevention of glare**

A light, other than a high-beam headlight, fitted to a heavy vehicle must be built and adjusted to provide the necessary amount of light, without dazzling the driver of another vehicle approaching, or being approached by, the vehicle.

**38 Pairs of lights**

If lights are required under this Regulation to be fitted to a heavy vehicle in pairs—

- (a) a light must be fitted on each side of the longitudinal axis of the vehicle; and
- (b) the centre of each light in a pair must be the same distance from the longitudinal axis of the vehicle; and
- (c) the centre of each light in a pair must be at the same height above ground level; and
- (d) each light in a pair must project approximately the same amount of light of the same colour.

**Division 3 Headlights****39 Headlights to be fitted to vehicles**

- (1) A heavy motor vehicle with 4 or more wheels must be fitted with a pair of low-beam headlights.
- (2) A heavy motor vehicle with fewer than 4 wheels must be fitted with at least 1 low-beam headlight.

- (3) If a heavy motor vehicle built after 1934 can travel at more than 60km/h—
  - (a) each low-beam headlight fitted as required by subsection (1) or (2) must be able to work in the high-beam position; or
  - (b) the vehicle must be fitted with—
    - (i) if the vehicle has 4 or more wheels—a pair of headlights that can work in the high-beam position; or
    - (ii) if the vehicle has fewer than 4 wheels—at least 1 headlight that can work in the high-beam position.
- (4) Additional headlights may be fitted to a heavy motor vehicle with 4 or more wheels built before 1970.
- (5) Additional pairs of headlights may be fitted to a heavy motor vehicle with 4 or more wheels built after 1969.

#### **40 How headlights are to be fitted**

- (1) The centres of low-beam headlights fitted as a pair on a heavy motor vehicle with 4 or more wheels must be at least 600mm apart.
- (2) However, subsection (1) does not apply to a heavy motor vehicle built before 1970 if the centres of its low-beam headlights—
  - (a) were less than 600mm apart when the vehicle was built; and
  - (b) are not nearer than they were when the vehicle was built.
- (3) The centre of a low-beam headlight fitted to a heavy motor vehicle built after June 1953 must be—
  - (a) at least 500mm above ground level; and
  - (b) not more than 1.4m above ground level.

**41 How additional headlights are to be fitted**

If 2 or more additional headlights are fitted to a heavy motor vehicle with 4 or more wheels, the additional headlights must as far as possible be fitted in pairs.

**42 Performance of headlights**

- (1) When on, a headlight, or additional headlight, fitted to a heavy vehicle must—
  - (a) show only white light; and
  - (b) project its main beam of light ahead of the vehicle.
- (2) A headlight must be fitted to a heavy vehicle so the light from it does not reflect off the vehicle into the driver's eyes while in the normal driving position.

**43 Effective range of headlights**

- (1) When on at night—
  - (a) a low-beam headlight fitted to a heavy vehicle must illuminate the road ahead of the vehicle for at least 25m; and
  - (b) a high-beam headlight fitted to a heavy vehicle must illuminate the road ahead of the vehicle for at least 50m.
- (2) However, a low-beam headlight fitted to a heavy vehicle built before 1931 need only illuminate the road ahead of the vehicle for 12m.

**44 Changing headlights from high-beam to low-beam position**

- (1) A heavy motor vehicle built after 1934 that can travel at more than 60km/h must be fitted with a dipping device enabling the vehicle's driver in the normal driving position—
  - (a) to change the headlights from the high-beam position to the low-beam position; or

- (b) simultaneously to switch off a high-beam headlight and switch on a low-beam headlight.
- (2) A heavy vehicle built after June 1953 that can travel at more than 60km/h must also be fitted with a device to indicate to the driver in the normal driving position that the headlights are in the high-beam position.
- (3) A headlight fitted to a heavy vehicle that is not fitted with a dipping device mentioned in subsection (1) must operate in the low-beam position.
- (4) When a headlight fitted to a heavy vehicle is switched to the low-beam position, any other headlight on the vehicle must operate only in the low-beam position or be off.

## **Division 4                  Parking lights**

### **45                  Parking lights**

- (1) A heavy motor vehicle with 4 or more wheels built after June 1953 must be fitted with a pair of parking lights.
- (2) A pair of parking lights fitted to a heavy motor vehicle must be fitted with the centre of each light—
  - (a) at least 600mm from the centre of the other light; and
  - (b) not more than 510mm from the nearer side of the vehicle.
- (3) However, a pair of parking lights fitted to a heavy motor vehicle less than 1300mm wide may be fitted with the centre of each light not less than 400mm from the centre of the other light.
- (4) When on, a parking light fitted to a heavy motor vehicle must—
  - (a) show a white or yellow light visible 200m from the front of the vehicle; and
  - (b) not use more than 7W.

- 
- (5) A parking light fitted to a heavy motor vehicle built after 1969 must be wired so the parking light is on when a headlight on the vehicle is on.

## Division 5                      Daytime running lights

### 46                      Daytime running lights

- (1) A pair of daytime running lights may be fitted to a heavy motor vehicle.
- (2) A pair of daytime running lights fitted to a heavy motor vehicle with 4 or more wheels must be fitted with the centre of each light—
- (a) at least 600mm from the centre of the other light; and
  - (b) not more than 510mm from the nearer side of the vehicle.
- (3) However, a pair of daytime running lights fitted to a heavy motor vehicle less than 1300mm wide may be fitted with the centre of each light not less than 400mm from the centre of the other light.
- (4) When on, a daytime running light fitted to a heavy motor vehicle must—
- (a) show a white or yellow light visible from the front of the vehicle; and
  - (b) not use more than 25W.

*Note—*

The third edition ADRs only allow white daytime running lights.

- (5) Daytime running lights fitted to a heavy motor vehicle must be wired so they are off when a headlight, other than a headlight being used as a flashing signal, is on.
- (6) In this section—

***daytime running lights*** means lights fitted to the front of a vehicle for improving visibility in the daytime.

## **Division 6                      Tail-lights**

### **47            Tail-lights generally**

- (1) Subject to subsections (2) and (3), a heavy vehicle must have at least 1 tail-light fitted on or towards the rear of the vehicle.
- (2) A heavy motor vehicle with 4 or more wheels built after 1959 must have at least 1 tail-light fitted on or towards each side of the rear of the vehicle.
- (3) A heavy trailer built after June 1973 must have at least 1 tail-light fitted on or towards each side of the rear of the vehicle.
- (4) The centre of a tail-light mentioned in subsection (1), (2) or (3) must not be more than—
  - (a) 1.5m above ground level; or
  - (b) if it is not practicable to fit the light lower, 2.1m above ground level.
- (5) A heavy vehicle may have 1 or more additional tail-lights at any height above ground level.

### **48            Pattern of fitting tail-lights**

- (1) If only 1 tail-light is fitted to a heavy vehicle, it must be fitted in the centre or to the right of the centre of the rear of the vehicle.
- (2) If 2 or more tail-lights are fitted to a heavy vehicle, at least 2 must be fitted as a pair.
- (3) Tail-lights fitted in accordance with this Division may also serve as rear clearance lights if they are fitted to a heavy vehicle in accordance with section 54(3).

### **49            Performance of tail-lights**

When on, a tail-light of a heavy vehicle must—



- (a) show a red light visible 200m from the rear of the vehicle; and
- (b) not use more than 7W.

## **50 Wiring of tail-lights**

A tail-light of a heavy motor vehicle must be wired to come on, and stay on, when a parking light or headlight on the vehicle is on, unless an external switch is fitted to operate the tail-light.

## **Division 7 Number plate lights**

### **51 Number plate lights**

- (1) At least 1 number plate light must be fitted to the rear of a heavy vehicle.
- (2) When on at night, the number plate light fitted to the rear of a heavy vehicle must illuminate a number plate on the rear of the vehicle with white light, so the characters on the number plate can be read at least 20m from the rear of the vehicle.
- (3) A number plate light fitted to a heavy vehicle—
  - (a) may be combined with another light; and
  - (b) must not project white light to the rear of the vehicle other than by reflection; and
  - (c) must not obscure the characters on the number plate; and
  - (d) must be wired to come on, and stay on, when a parking light, headlight or tail-light on the vehicle is on.

## Division 8 Clearance lights

### 52 Front clearance lights

- (1) Front clearance lights may only be fitted to a heavy vehicle that is at least 1.8m wide.
- (2) A pair of front clearance lights must be fitted to a heavy motor vehicle that is at least 2.2m wide, or a prime mover.
- (3) The centre of a front clearance light fitted to a heavy vehicle must be—
  - (a) not more than 400mm from the nearer side of the vehicle; and
  - (b) if the vehicle was built after June 1953—
    - (i) at least 750mm higher than the centre of any low-beam headlight fitted to the vehicle; or
    - (ii) not lower than the top of the windscreen.
- (4) However, a front clearance light fitted to a heavy vehicle may be mounted on an external rear vision mirror or a mirror support if, when the mirror is correctly adjusted, no part of the lens of the clearance light is visible to the vehicle's driver in the normal driving position.
- (5) When on, a front clearance light fitted to a heavy vehicle must—
  - (a) show a white or yellow light visible 200m from the front of the vehicle; and
  - (b) not use more than 7W.
- (6) In this section—

***front clearance light*** means a light fitted to the front of a vehicle that indicates the dimension limits of the vehicle when viewed from the front.

---

**53 External cabin lights**

- (1) A heavy motor vehicle fitted with front clearance lights may also have additional forward-facing lights on or above the roof of its cabin.
- (2) The additional forward-facing lights must be spaced evenly between the front clearance lights, with their centres at least 120mm apart.
- (3) When on, an additional forward-facing light fitted to a heavy motor vehicle must—
  - (a) show a white or yellow light; and
  - (b) not use more than 7W.

**54 Rear clearance lights**

- (1) Rear clearance lights may only be fitted to a heavy vehicle that is at least 1.8m wide.
- (2) A pair of rear clearance lights must be fitted to the rear of a heavy vehicle that is at least 2.2m wide.
- (3) The centre of a rear clearance light fitted to a heavy vehicle must be—
  - (a) not more than 400mm from the nearer side of the vehicle; and
  - (b) if practicable, at least 600mm above ground level.
- (4) When on, a rear clearance light fitted to a heavy vehicle must—
  - (a) show a red light visible 200m from the rear of the vehicle; and
  - (b) not use more than 7W.
- (5) In this section—

***rear clearance light*** means a light fitted to the rear of a vehicle that indicates the dimension limits of the vehicle when viewed from the rear.

## **Division 9                      Side marker lights**

### **55            Vehicles needing side marker lights**

- (1) A pair of side marker lights must be fitted towards the rear of the sides of a heavy motor vehicle that is longer than 7.5m and at least 2.2m wide.
- (2) A pole-type trailer or a heavy motor vehicle built to tow a pole-type trailer, each with at least 1 cross-bar or bolster, must have a side marker light fitted to each side of the back or only cross-bar or bolster.
- (3) A pole-type trailer with 2 or more cross-bars or bolsters may also have a side marker light fitted to each side of the front cross-bar or bolster.
- (4) At least 2 side marker lights must be fitted to each side of—
  - (a) a heavy trailer, other than a pole-type trailer, that is at least 2.2m wide and not longer than 7.5m; and
  - (b) a semitrailer that is not longer than 7.5m.
- (5) At least 3 side marker lights must be fitted to each side of—
  - (a) a heavy trailer, other than a pole-type trailer, that is at least 2.2m wide and longer than 7.5m; and
  - (b) a semitrailer that is longer than 7.5m.

### **56            Location of side marker lights**

- (1) The centre of a side marker light fitted to a heavy vehicle must not be more than 150mm from the nearer side of the vehicle.
- (2) A front side marker light fitted to a heavy motor vehicle must be towards the front of the side of the vehicle with no part of the lens visible to the driver in the normal driving position.
- (3) The centre of a front side marker light fitted to a heavy trailer must be—
  - (a) within 300mm of the front of the side of the trailer; or

- 
- (b) if the construction of the trailer makes it impracticable to comply with paragraph (a)—as near as practicable to the front of the trailer.
  - (4) The centre of a rear side marker light fitted to a heavy vehicle must be—
    - (a) within 300mm of the rear of the side of the vehicle; or
    - (b) if the construction of the vehicle makes it impracticable to comply with paragraph (a)—as near as practicable to the rear of the vehicle.
  - (5) Side marker lights fitted to a heavy vehicle must, as far as practicable, be evenly spaced along the side of the vehicle.
  - (6) Subsections (2) to (5) do not apply to side marker lights fitted to a cross-bar or bolster of a pole-type trailer.
  - (7) Only the side marker lights nearest to the rear need be fitted to a heavy vehicle if complying with subsections (3) and (4) would result in the front and rear side marker lights being less than 2.5m apart.
  - (8) A side marker light fitted to a heavy vehicle must be fitted so—
    - (a) its centre is at least 600mm above ground level; and
    - (b) its centre is not more than—
      - (i) 1.5m above ground level; or
      - (ii) if it is not practicable to fit it lower, 2.1m above ground level; and
    - (c) it is, as far as practicable, in a row of side marker lights along the side of the vehicle.
  - (9) Subsection (8)(a) does not apply to a side marker light that is not required to be fitted to the heavy vehicle under section 55.

## **57 Performance of side marker lights**

- (1) When on, a side marker light fitted to a heavy vehicle must—
  - (a) show a light visible 200m from the vehicle; and
  - (b) not use more than 7W.

- (2) When on, a side marker light fitted to a heavy vehicle must show—
  - (a) to the front of the vehicle—a yellow light; and
  - (b) to the rear of the vehicle—
    - (i) if the light also operates as a rear light or reflector—a red light; and
    - (ii) in any other case—a red or yellow light.
- (3) If a pole-type trailer with 2 or more cross-bars or bolsters has side marker lights permitted by section 55(3)—
  - (a) the side marker lights fitted to the front cross-bar or bolster must, when on, show a yellow light; and
  - (b) the side marker lights fitted to the back cross-bar or bolster must, when on, show—
    - (i) if the light also operates as a rear light or reflector—a red light; and
    - (ii) in any other case—a red or yellow light.

## **58 Side marker lights and rear clearance lights**

The side marker light nearest to the rear of a vehicle may also be a rear clearance light for section 54.

## **Division 10 Brake lights**

### **59 Fitting brake lights**

- (1) A brake light must be fitted to the rear of a heavy vehicle built after 1934.
- (2) A pair of brake lights must be fitted to the rear of—
  - (a) a heavy motor vehicle built after 1959 that has 4 or more wheels; and
  - (b) a heavy trailer built after June 1973.
- (3) The centre of a brake light fitted to a heavy vehicle must be—

- 
- (a) at least 350mm above ground level; and
  - (b) not more than—
    - (i) 1.5m above ground level; or
    - (ii) if it is not practicable to fit the light lower, 2.1m above ground level.
- (4) A heavy vehicle may be fitted with 1 or more additional brake lights.
- (5) The centre of an additional brake light fitted to a heavy vehicle must be at least 350mm above ground level.
- (6) If only 1 brake light is fitted to a heavy vehicle, it must be fitted in the centre or to the right of the centre of the rear of the vehicle.

## 60 Performance and operation of brake lights

- (1) When on, a heavy vehicle's brake light must show a red light visible 30m from the rear of the vehicle.
- (2) A brake light fitted to a heavy motor vehicle must come on, if it is not already on, when a service brake is applied.
- (3) Subsection (2) does not apply if the controls in the heavy motor vehicle that start the engine are in a position that makes it impossible for the engine to operate.
- (4) A brake light fitted to a heavy trailer must come on when—
- (a) the brake light of the towing vehicle comes on; or
  - (b) a brake control on the towing vehicle, that independently activates the service brake on the trailer, is operated.
- (5) A brake light fitted to a heavy vehicle may be operated by an engine brake or similar device if the device does not interfere with the proper operation of the brake light.
- (6) In this section—

***engine brake*** means a device that uses force within a vehicle's engine or transmission system for the purpose of deceleration of the vehicle.

## **Division 11                    Reversing lights**

### **61            Reversing lights**

- (1) One or more reversing lights may be fitted to the rear of a heavy vehicle and on each side towards the rear of the vehicle.
- (2) A reversing light fitted to a heavy vehicle must have its centre not more than 1.2m above ground level.
- (3) When on, a reversing light fitted to a heavy vehicle must show a white or yellow light to the rear or to the side and rear of the vehicle.

*Note—*

The third edition ADRs only allow white reversing lights.

- (4) A reversing light fitted to a heavy motor vehicle must be wired so it operates only when the vehicle is reversing or in reverse gear.
- (5) A reversing light fitted to a heavy trailer must be wired so it operates only when the towing vehicle is reversing or in reverse gear.
- (6) A yellow reversing light fitted to a heavy vehicle may also operate as a direction indicator light.

## **Division 12                    Direction indicator lights**

### **62            Direction indicator lights on heavy motor vehicles**

- (1) A heavy motor vehicle with 4 or more wheels that was built after August 1966 must have—
  - (a) a pair of direction indicator lights fitted on, or towards, its front that face forwards; and
  - (b) a pair of direction indicator lights fitted on, or towards, its rear that face backwards.
- (2) A heavy motor vehicle with fewer than 4 wheels that was built after June 1975 must have—



- 
- (a) a pair of direction indicator lights fitted on, or towards, its front that face forwards; and
  - (b) a pair of direction indicator lights fitted on, or towards, its rear that face backwards.
- (3) A heavy motor vehicle that is not required to have direction indicator lights may have—
- (a) 1 or more pairs of direction indicator lights that are visible from both the front and rear of the vehicle; or
  - (b) both—
    - (i) a pair of direction indicator lights fitted on, or towards, its front that face forwards; and
    - (ii) a pair of direction indicator lights fitted on, or towards, its rear that face backwards.

### **63 Direction indicator lights on trailers**

- (1) A heavy trailer built after June 1973 must have a pair of direction indicator lights fitted on, or towards, its rear that face backwards.
- (2) A heavy trailer that is not required to have direction indicator lights may have 1 or more pairs of direction indicator lights fitted on, or towards, its rear that face backwards.

### **64 Location of direction indicator lights**

- (1) A pair of direction indicator lights fitted to a heavy vehicle must have the centre of each light at least—
  - (a) for a vehicle with a width of not more than 1.3m—400mm from the centre of the other light; or
  - (b) for a vehicle with a width of more than 1.3m—600mm from the centre of the other light.
- (2) The centre of each direction indicator light fitted to a heavy vehicle must be at least 350mm above ground level.

- (3) The centre of each light in a pair of direction indicator lights required to be fitted to a heavy vehicle must not be more than—
  - (a) 1.5m above ground level; or
  - (b) if it is not practicable for the light to be fitted lower—2.1m above ground level.

## **65 Operation and visibility of direction indicator lights**

- (1) A direction indicator light fitted to a heavy motor vehicle must—
  - (a) when operating, display regular flashes of light at a rate of—
    - (i) for a heavy motor vehicle with 4 or more wheels—at least 60 but not more than 120 flashes per minute; or
    - (ii) for another heavy motor vehicle—at least 45 but not more than 120 flashes per minute; and
  - (b) be able to be operated from the normal driving position by the vehicle's driver; and
  - (c) be wired to an audible or visible device in the vehicle that tells the driver in the normal driving position that the direction indicator light is operating; and
  - (d) flash at the same time and rate as any other direction indicator lights fitted on the same side of the vehicle.
- (2) A direction indicator light fitted to a side of a heavy trailer must, when operating, flash at the same time and rate as the direction indicator light or lights fitted to the same side of the towing vehicle.
- (3) The flashes of light displayed by a direction indicator light fitted to a heavy vehicle must be—
  - (a) for a light facing forwards—white or yellow; or
  - (b) for a light facing backwards—
    - (i) yellow; or

- 
- (ii) if the vehicle was built before July 1973—red or yellow; and
  - (c) for a light facing out from the side of the vehicle—
    - (i) white or yellow towards the front and side; and
    - (ii) if the vehicle was built before July 1973—red or yellow towards the rear and side; and
    - (iii) if the vehicle was built after June 1973—yellow towards the rear and side.

*Note—*

The third edition ADRs only allow yellow direction indicator lights.

- (4) If a heavy motor vehicle's direction indicator lights display only yellow light, the vehicle may be equipped to allow the lights to operate simultaneously on both sides of the vehicle, if an audible or visible signal tells the driver in the normal driving position when the lights are operating simultaneously.
- (5) When on, a direction indicator light fitted to a heavy vehicle must be visible 30m from—
  - (a) for a light facing forwards—the front of the vehicle; or
  - (b) for a light facing backwards—the rear of the vehicle; or
  - (c) for a light facing out from the side of the vehicle—that side of the vehicle.
- (6) When on, each direction indicator light in at least 1 pair of lights fitted on or towards the front of a heavy vehicle that is a prime mover or a heavy motor vehicle longer than 7.5m, must be visible at a point—
  - (a) 1.5m at right angles from the side of the vehicle where the light is fitted; and
  - (b) in line with the rear of the vehicle.

## **Division 13                      Fog lights**

### **66            Front fog lights**

- (1) A pair of front fog lights may be fitted to a heavy motor vehicle.
- (2) A pair of front fog lights fitted to a heavy motor vehicle with 4 or more wheels must have the centre of each light not more than 400mm from the nearer side of the vehicle unless the centres of the lights are at least 600mm apart.
- (3) If the top of a front fog light fitted to a heavy motor vehicle is higher than the top of any low-beam headlight on the vehicle, the centre of the fog light must not be higher than the centre of the low-beam headlight.
- (4) A front fog light fitted to a heavy motor vehicle must—
  - (a) when on—
    - (i) project white or yellow light in front of the vehicle; and
    - (ii) be a low-beam light; and
  - (b) be able to be operated independently of any headlight; and
  - (c) be fitted so the light from it does not reflect off the vehicle into the driver's eyes while in the normal driving position.

### **67            Rear fog lights**

- (1) A heavy vehicle may have fitted to its rear—
  - (a) a pair of rear fog lights; or
  - (b) 1 rear fog light fitted on, or to the right of, the centre of the rear of the vehicle.
- (2) A rear fog light fitted to a heavy vehicle must—
  - (a) have its centre—
    - (i) not more than 1.5m above ground level; and

- (ii) at least 100mm from the centre of a brake light; and
  - (b) when on, project red light behind the vehicle; and
  - (c) not use more than 27W; and
  - (d) be wired to a visible device in the vehicle that tells the driver in the normal driving position that the rear fog light is on.
- (3) In this section—
- rear fog light* means a light used on a heavy vehicle to make it more easily visible from the rear in dense fog.

## Division 14 Interior lights

### 68 Interior lights

A heavy vehicle may be fitted with interior lights that illuminate any interior part of the vehicle.

## Division 15 Reflectors

### 69 General requirements for reflectors

- (1) A reflector fitted to a heavy vehicle must show a red, white or yellow reflection of light when light is projected directly onto the reflector at night by another vehicle's low-beam headlight that—
  - (a) is 45m from the reflector; and
  - (b) complies with the relevant vehicle standards.
- (2) The reflection must be clearly visible from the normal driving position of the driver of the other vehicle.
- (3) In this section—

*relevant vehicle standards* means—

- (a) in relation to a heavy vehicle—the vehicle standards prescribed by this Regulation; or
- (b) in relation to a vehicle that is not a heavy vehicle—the vehicle standards with which a vehicle other than a heavy vehicle must comply before it may be registered under a law of a participating jurisdiction providing for the registration of vehicles other than heavy vehicles.

## **70 Rear reflectors**

- (1) A heavy motor vehicle with 4 or more wheels, and a heavy trailer, must have towards each side of its rear a rear-facing reflector that shows a red reflection of light when light is projected directly onto the reflector.
- (2) The centre of each reflector fitted to a heavy vehicle mentioned in subsection (1) must be—
  - (a) at the same height above ground level; and
  - (b) not more than 1.5m above ground level.
- (3) A reflector fitted to a heavy vehicle mentioned in subsection (1) must not be more than 400mm from the nearer side of the vehicle.
- (4) A heavy vehicle fitted with rear-facing reflectors under subsection (1) may be fitted with additional reflectors that show a red reflection of light when light is projected directly onto the reflectors—
  - (a) at any height above ground level; or
  - (b) at any distance from the side of the vehicle.

## **71 Compulsory side reflectors on pole-type trailers**

- (1) The pole of a pole-type trailer must be fitted with side-facing reflectors that show a red or yellow reflection of light when light is projected directly onto the reflectors.
- (2) The reflectors mentioned in subsection (1) must be fitted as follows—

- (a) 1 reflector must be fitted to the middle third of the left and right faces of the pole of the pole-type trailer;
  - (b) the front reflector must not be more than 3m from the front of the pole-type trailer;
  - (c) the other reflectors must not be more than 3m apart.
- (2) Additional side-facing reflectors may be fitted to a pole-type trailer in accordance with section 72.

## **72 Optional side reflectors**

- (1) A heavy vehicle may be fitted with side-facing reflectors.
- (2) A side-facing reflector fitted to a heavy vehicle must show the following coloured reflection of light when light is projected directly onto the reflector—
- (a) for a side-facing reflector fitted towards the front of the vehicle—white or yellow;
  - (b) for a side-facing reflector fitted towards the rear of the vehicle—red or yellow;
  - (c) for a side-facing reflector fitted on the central part of the vehicle—yellow.

## **73 Compulsory front reflectors on particular trailers**

- (1) Each side of the front of a semitrailer other than a pole-type trailer, or a heavy trailer that is at least 2.2m wide, must be fitted with a front-facing reflector that shows a white or yellow reflection of light when light is projected directly onto the reflector.
- (2) The front of the front or only cross-bar or bolster of a pole-type trailer must be fitted with a front-facing reflector that shows a white or yellow reflection of light when light is projected directly onto the reflector.
- (3) Each reflector fitted to a heavy trailer must have its centre—
- (a) at the same height above ground level; and
  - (b) not more than 1.5m above ground level; and

- (c) not more than 400mm from the nearer side of the vehicle.
- (4) Additional front-facing reflectors may be fitted to a trailer mentioned in subsection (1) in accordance with section 74.

## **74 Optional front reflectors**

- (1) A heavy motor vehicle with 4 or more wheels, or a heavy trailer, may have fitted towards each side of its front 1 or more front-facing reflectors that show a white or yellow reflection of light when light is projected directly onto the reflector.
- (2) A heavy motor vehicle with fewer than 4 wheels may have 1 or more front-facing reflectors that show a white or yellow reflection of light when light is projected directly onto the reflector.
- (3) The centre of at least 1 reflector on each side of the front of a heavy vehicle must be—
  - (a) at the same height above ground level as the centre of the other reflector; and
  - (b) the same distance from the longitudinal axis of the vehicle as the centre of the other reflector; and
  - (c) at least—
    - (i) if the vehicle has a width of less than 1.3m—400mm from the centre of the other reflector; or
    - (ii) if the vehicle has a width of 1.3m or more—600mm from the centre of the other reflector.



---

**Division 16**                      **Warning lights and signs on buses carrying children****75**        **Application of Div 16**

This Division applies to a heavy vehicle that is a bus used mainly for carrying children other than a bus fitted with warning lights before July 1999.

**76**        **Fitting of warning lights and signs**

- (1) Two warning lights and a warning sign must be fitted to the front and rear of the bus.
- (2) The warning lights must be fitted—
  - (a) on each side of, and the same distance from, the centre of the warning sign; and
  - (b) with the edge of the warning sign not more than 100mm from the nearest point on the lens of the warning lights; and
  - (c) with the distance between the warning lights at least 300mm at the nearest point; and
  - (d) so no part of the bus obstructs the light displayed—
    - (i) 30° to the left and right of the centre of each light; and
    - (ii) 10° above and below the centre of each light.
- (3) The warning lights may be on the warning sign if the words or image on the sign are not obscured.
- (4) The warning lights at the same end of the bus must be fitted—
  - (a) at the same height; and
  - (b) as high as practicable; and
  - (c) with the lowest point on the lens of each light not lower than midway between the highest and lowest points on the bus body.

- (5) If the centres of the warning lights are less than 1.8m above ground level, no part of the warning lights or warning sign may be on the left side of the bus.
- (6) Any requirement of a third edition ADR about warning lights or warning signs does not apply to a bus to which this Division applies.

## **77 Operation and performance of warning lights**

- (1) A warning light attached to the bus, when switched on, must—
  - (a) emit a flashing yellow-coloured light; and
  - (b) flash between 90 and 180 times per minute.
- (2) The warning lights at the same end of the bus must flash alternately.
- (3) Unless the driver of the bus has turned the warning lights off, they must operate automatically when a door on the bus opens and for at least 10 seconds, and not more than 20 seconds, after all the doors on the bus have closed.
- (4) The bus must have an audible or visible signal that tells the driver of the bus in the normal driving position when the warning lights are flashing.
- (5) The bus must be fitted with a switch that allows the driver of the bus to turn the warning lights off from the normal driving position.
- (6) A warning light fitted to the bus must have—
  - (a) an effective lit lens area of at least 60cm<sup>2</sup>; and

- (b) a luminous intensity (in candela) of at least the values mentioned in the following table when measured at the angles mentioned in the table.

Vertical angle from centre of light	Horizontal angle from centre of light								
	-30°	-20°	-10°	-5°	0°	5°	10°	20°	30°
10°				50	80	50			
5°		180	320	350	450	350	320	180	
0°	75	450	1 000	1 250	1 500	1 250	1 000	450	75
-5°	40	270	450	570	600	570	450	270	40
-10°				75	75	75			

- (7) For the purposes of subsection (6)(b), the luminous intensity of a light is to be measured using the test method mentioned in third edition ADR 6.

## 78 Specifications for warning signs

- (1) A warning sign at the front of the bus must show—
- the words ‘SCHOOL BUS’ in capital letters at least 100mm high; or
  - the required image.
- (2) A warning sign at the rear of the bus must show the required image.
- (3) The warning sign showing the required image must—
- be a rectangular shape at least—
    - if warning lights are on the warning sign—550mm long and 400mm high; or
    - otherwise—400mm long and 250mm high; and
  - have a black border; and
  - have black graphics; and
  - have a yellow surface complying with class 1 or 2 of AS 1906 ‘Retroreflective Materials and Devices for Road Traffic Control Purposes’.

- (4) In this section—

*required image* means an image of 2 children in the same proportions as the children in AS 1743 'Road Signs—Specifications', image W6-3, with the image of the taller child at least 230mm high.

## **Division 17                    Other lights, reflectors, rear marking plates or signals**

### **79            Other lights and reflectors**

- (1) An exempt vehicle may be fitted with any light or reflector.
- (2) A special use vehicle may be fitted with 1 or more flashing yellow lights.
- (3) A heavy vehicle may not be fitted with any light or reflector not mentioned in this Regulation other than as required or permitted by the Law or national regulations.
- (4) A heavy vehicle, other than an exempt vehicle or a special use vehicle, must not be fitted with a light that flashes other than as required or permitted by the Law or national regulations.
- (5) A heavy vehicle, other than an exempt vehicle, must not be fitted with a light or reflector that—
  - (a) shows a red light to the front; or
  - (b) shows a white light to the rear; or
  - (c) is shaped or located in a way that reduces the effectiveness of a light or reflector required to be fitted to the vehicle under this Regulation.
- (6) Any requirements in a third edition ADR that are inconsistent with subsection (1) do not apply to an exempt vehicle.
- (7) Any requirements in a third edition ADR that are inconsistent with subsection (2) do not apply to a special use vehicle.
- (8) In this section—

***dimension exemption*** means an exemption under Part 4.5 of the Law from compliance with a prescribed dimension requirement.

***special use vehicle*** means any of the following vehicles—

- (a) a heavy vehicle built or fitted for use in hazardous situations on a road;
- (b) a heavy vehicle used on a road under a dimension exemption;
- (c) a heavy vehicle built or fitted to accompany a heavy vehicle mentioned in paragraph (b);
- (d) a heavy vehicle that is a bus fitted, before July 1999, with a sign telling road users that the bus carries children.

## **80 Rear marking plates**

- (1) Rear marking plates must be fitted to the following vehicles in a way complying with VSB 12—
  - (a) a heavy motor vehicle with a GVM of more than 12t, other than a bus fitted with hand grips or similar equipment for standing passengers to hold;
  - (b) a heavy trailer with a GTM of more than 10t.
- (2) Subsection (1) applies to a heavy vehicle even if it was built before the day stated in VSB 12.
- (3) Rear marking plates may be fitted to a heavy motor vehicle with a GVM not over 12t or a heavy trailer with a GTM not over 10t.
- (4) In this section—

***rear marking plate*** means a plate that complies with VSB 12.

*Examples of rear marking plates—*

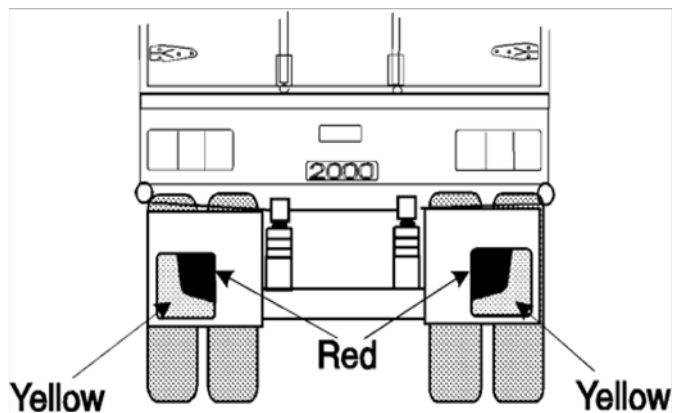

**An example of rear marking plates**

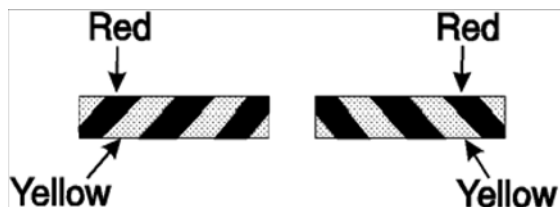

**An alternative pattern for rear marking plates**

**VSB 12** means the ‘Standards Bulletin VSB 12—Rear Marking Plates’ published by the Vehicle Safety Branch of the Western Australian Department of Planning and Infrastructure.

*Note—*

A copy of the bulletin may be obtained from the website of the Commonwealth Department of Infrastructure and Transport at <[www.infrastructure.gov.au](http://www.infrastructure.gov.au)>.

## **81 Signalling devices**

(1) This section applies to a heavy motor vehicle if—

- 
- (a) the vehicle is not fitted with a brake light mentioned in Division 10 or a direction indicator light mentioned in Division 12; and
  - (b) the vehicle's construction would otherwise prevent the driver in the normal driving position from hand signalling an intention—
    - (i) to turn or move the vehicle to the right; or
    - (ii) to stop or suddenly reduce the vehicle's speed.
- (2) The heavy motor vehicle must be fitted with—
- (a) a mechanical signalling device complying with section 82; or
  - (b) a pair of turn signals complying with section 83.

## **82 Mechanical signalling devices**

- (1) A mechanical signalling device fitted to a heavy motor vehicle must—
- (a) be fitted to the right side of the vehicle; and
  - (b) be able to be operated by the vehicle's driver from the normal driving position; and
  - (c) consist of a white or yellow representation of an open human hand at least 15cm long; and
  - (d) be constructed so that the vehicle's driver can keep the device—
    - (i) in a neutral position so that it is unlikely that the driver of another vehicle or anyone else would regard it as a signal; and
    - (ii) in a horizontal position with the palm of the hand facing forwards and the fingers pointing out at a right angle to the vehicle to signal an intention to turn or move right; and
    - (iii) with the palm of the hand facing forwards and the fingers pointing upwards to signal an intention to stop or reduce speed suddenly.

- (2) When a mechanical signalling device fitted to a heavy motor vehicle is in a position mentioned in subsection (1)(d)(ii) or (iii), the complete hand must be clearly visible from both the front and the rear of the vehicle at a distance of 30m.

### **83 Turn signals**

A turn signal fitted to a heavy motor vehicle must—

- (a) consist of a steady or flashing illuminated yellow sign at least 150mm long and 25mm wide that—
  - (i) when in operation—is kept horizontal; and
  - (ii) when not in operation—is kept in a position so it is unlikely that the driver of another vehicle or anyone else would regard it as a signal; and
- (b) be fitted to the side of the vehicle at least 500mm and not more than 2.1m above ground level, in a position so that the vehicle's driver, from the normal driving position, can see whether the signal is in operation; and
- (c) be able to be operated by the vehicle's driver from the normal driving position; and
- (d) when in operation—be visible from both the front and rear of the vehicle at a distance of 30m.

## **Part 7 Braking systems**

### **Division 1 Brake requirements for all heavy vehicles**

#### **84 Components of a braking system**

- (1) A brake tube or hose fitted to a heavy vehicle must—
- (a) be manufactured from a material appropriate to its intended use in the vehicle; and



- 
- (b) be long enough to allow for the full range of steering and suspension movements of the vehicle; and
- (c) be fitted to prevent it being damaged during the vehicle's operation by—
- (i) a source of heat; or
  - (ii) any movement of the parts to which it is attached or near.
- (2) Each component of the braking system of a heavy vehicle must comply with the design and performance requirements of any of the following—
- (a) a relevant Australian Standard or British Standard; or
  - (b) a relevant standard approved by any of the following bodies—
    - American Society of Automotive Engineers
    - American National Standards Institute
    - Japanese Standards Association
    - Deutsches Institut für Normung
    - International Organisation for Standardisation
    - European Committee for Standardization (CEN).

## **85 Provision for wear**

The braking system of a heavy vehicle must allow for adjustment to take account of normal wear in the braking system.

## **86 Supply of air or vacuum to brakes**

- (1) If air brakes are fitted to a heavy vehicle—
- (a) the vehicle's air brake compressor must be able to build up air pressure to at least 80% of the vehicle's governor cut-out pressure in not more than 5 minutes after the compressed air reserve is fully used up; and

- (b) the air storage tanks in the vehicle's braking system must have sufficient capacity to allow 5 applications of the service brakes before the air pressure drops below half the vehicle's governor cut-out pressure; and
  - (c) there must be an automatic or manual condensate drain valve at the lowest point of each air brake reservoir in the vehicle's braking system; and
  - (d) any spring brake fitted to the vehicle must not operate before the warning mentioned in section 90(4)(a) or 93(3)(a) has been given.
- (2) If vacuum brakes are fitted to a heavy vehicle, the vacuum supply must be able to build up vacuum—
- (a) to the level when the warning signal mentioned in section 90(4)(a) or 93(3)(a) no longer operates within 30 seconds after the vacuum reserve is fully used up; and
  - (b) to the normal working level within 60 seconds after the vacuum reserve is fully used up.
- (3) In this section—

***compressed air reserve***, in relation to a vehicle, means compressed air stored on the vehicle for the purpose of supply to the vehicle's braking system.

***condensate drain valve*** means a device used to remove water from the compressed air reserve for a vehicle fitted with air brakes.

***governor cut-out pressure***, in relation to a vehicle, means the air pressure at which the vehicle's air brake compressor stops supplying air to the vehicle's air brake reservoir.

***spring brake*** means a brake using 1 or more springs to store the energy needed to operate the brake.

***vacuum reserve***, in relation to a vehicle, means air at a low pressure stored on the vehicle for the purpose of supply to the vehicle's braking system.

---

**87 Performance of braking systems**

- (1) The braking system of a heavy motor vehicle built after 1930 or a heavy combination that includes a heavy motor vehicle built after 1930 must, on application of a brake, be able to produce the performance mentioned in subsections (2) to (4)—
  - (a) when the vehicle is on a dry, smooth, level road surface, free from loose material; and
  - (b) whether or not the vehicle has goods or passengers in it; and
  - (c) whether or not the vehicle is used alone or as part of a combination; and
  - (d) without part of the vehicle moving outside a straight path—
    - (i) centred on the longitudinal axis of the vehicle before the brake was applied; and
    - (ii) 3.7m wide.
- (2) The braking system of a heavy motor vehicle or heavy combination that includes a heavy motor vehicle built after 1930 must bring the vehicle from a speed of 35km/h to a stop within—
  - (a) 16.5m when the service brake is applied; and
  - (b) 40.5m when the emergency brake is applied.
- (3) The braking system of a heavy motor vehicle or heavy combination that includes a heavy motor vehicle built after 1930 must decelerate the vehicle, from any speed at which the vehicle can travel, by an average of at least—
  - (a) 2.8m a second a second when the service brake is applied; and
  - (b) 1.1m a second a second when the emergency brake is applied.
- (4) The braking system of a heavy motor vehicle or heavy combination that includes a heavy motor vehicle built after

1930 must achieve a peak deceleration of the vehicle, from any speed at which the vehicle can travel, of at least—

- (a) 4.4m a second a second when the service brake is applied; and
  - (b) 1.5m a second a second when the emergency brake is applied.
- (5) The parking brake of a heavy motor vehicle or heavy combination must be able to keep the vehicle, or any combination of which it is a part, stationary on a 12% gradient—
- (a) when the vehicle or combination is on a dry, smooth road surface, free from loose material; and
  - (b) whether or not the vehicle or combination has goods or passengers in it.

## **Division 2                      Heavy motor vehicle braking systems**

### **88      What braking system a heavy motor vehicle must have**

- (1) A heavy motor vehicle with 4 or more wheels built, or used, mainly for transporting goods or passengers by road must be fitted with—
- (a) a braking system that—
    - (i) consists of brakes fitted to all wheels of the vehicle; and
    - (ii) has at least 2 separate methods of activation, arranged so effective braking remains on at least 2 wheels if a method fails; or
  - (b) 2 independent brakes, each of which, when in operation, acts directly on at least half the number of wheels of the vehicle.
- (2) The braking system of a heavy motor vehicle mentioned in subsection (1) that was built after 1945 must have a service brake operating on all wheels that, when applied—

- 
- (a) acts directly on the wheels and not through the vehicle's transmission; or
  - (b) acts on a shaft between a differential of the vehicle and a wheel.
- (3) The braking system of a heavy motor vehicle with 4 or more wheels must have a parking brake that—
- (a) is held in the applied position by direct mechanical action without the intervention of an electrical, hydraulic or pneumatic device; and
  - (b) is fitted with a locking device that can hold the brake in the applied position; and
  - (c) has its own separate control.
- (4) The parking brake mentioned in subsection (3) may also be the heavy motor vehicle's emergency brake.
- (5) If 2 or more independent brakes are fitted to a heavy motor vehicle with 4 or more wheels, the brakes must be arranged so brakes are applied to all the wheels on at least 1 axle of the vehicle when any brake is operated.
- (6) In this section—
- independent brake***, in relation to a heavy vehicle, means—
- (a) a brake that is operated entirely separately from any other brake on the vehicle; or
  - (b) 2 or more brakes operated simultaneously by a drum, disc or part on which a shoe, band or friction pad makes contact, that is common to the brakes.

## **89 Operation of brakes on heavy motor vehicles**

The braking system on a heavy motor vehicle must be arranged to allow the vehicle's driver to apply the brakes from the normal driving position.

**90 Air or vacuum brakes on heavy motor vehicles**

- (1) If a heavy motor vehicle has air brakes, the vehicle's braking system must include at least 1 air storage tank.
- (2) If a heavy motor vehicle has vacuum brakes, the vehicle's braking system must include at least 1 vacuum storage tank.
- (3) An air storage tank or vacuum storage tank in a heavy motor vehicle's braking system must be built so the vehicle's service brake can be applied to meet the performance standards of section 87 at least twice if the vehicle's engine stops or the source of air or vacuum fails.
- (4) An air storage tank or vacuum storage tank in a heavy motor vehicle's braking system must—
  - (a) be built to give an audible or visible warning to the vehicle's driver, while in the normal driving position, of a lack of air or vacuum that would prevent the vehicle's service brake from being applied to meet the performance standards of section 87 at least twice; and
  - (b) be safeguarded by a check valve or other device against loss of air or vacuum if the supply of air or vacuum fails or leaks.
- (5) If air or vacuum brakes are fitted to a heavy motor vehicle equipped to tow a trailer, the vehicle's brakes must be able to stop the vehicle, at the performance standards for emergency brakes under section 87 if the trailer breaks away.
- (6) The braking system of a heavy motor vehicle equipped to tow a trailer fitted with air brakes must include protection against loss of air in the system.
- (7) The protection mentioned in subsection (6) must, if an air supply hose connecting the heavy motor vehicle and a trailer fails—
  - (a) operate automatically; and
  - (b) maintain enough air pressure to allow the brakes to be applied to meet performance standards for emergency brakes under section 87; and

- (c) include an audible or visible warning to the vehicle's driver in the normal driving position of a lack of air that would prevent the vehicle's service brake from being applied.

## **Division 3                    Heavy trailer braking systems**

### **91            What brakes a heavy trailer must have**

- (1) A heavy trailer must have brakes that operate on at least 1 wheel at each end of 1 or more axles of the trailer.
- (2) A semitrailer or converter dolly with a GTM over 2t must have brakes that operate on all its wheels.

### **92            Operation of brakes on a heavy trailer**

- (1) The braking system of a heavy trailer must allow the driver of the towing vehicle to operate the brakes from the normal driving position.
- (2) However, subsection (1) does not apply to an unloaded converter dolly that weighs under 3t if the heavy motor vehicle towing the converter dolly has a GVM over 12t.
- (3) The brakes on a heavy trailer must, if the trailer breaks away from the towing vehicle—
  - (a) operate automatically and quickly; and
  - (b) remain in operation for at least 15 minutes after the break-away; and
  - (c) be able to hold the trailer on a 12% grade while in operation after the break-away.

### **93            Air or vacuum brakes on heavy trailers**

- (1) If a heavy trailer has air brakes, its braking system must include at least 1 air storage tank.
- (2) If a heavy trailer has vacuum brakes, its braking system must include at least 1 vacuum storage tank.

- (3) An air storage tank or vacuum storage tank in the braking system of a heavy trailer must—
  - (a) be constructed to give an audible or visible warning to the driver of the towing vehicle, while in the normal driving position, of a lack of air or vacuum that would prevent the brakes from meeting the performance standards of section 87; and
  - (b) be safeguarded by a check valve or other device against loss of air or vacuum if the supply of air or vacuum fails or leaks.

## **Part 8 Control of emissions**

### **Division 1 Crank case gases and visible emissions**

#### **94 Crank case gases**

- (1) This section applies to a heavy motor vehicle with 4 or more wheels that is powered by a petrol engine and was built after 1971.
- (2) The heavy motor vehicle must be built to prevent, or fitted with equipment that prevents, gases emitted from the vehicle's engine crank case escaping to the atmosphere.
- (3) In this section—

*engine crank case*, in relation to a vehicle, means the case within which the crank shaft of the vehicle's engine is enclosed.

#### **95 Visible emissions**

- (1) This section applies to a heavy motor vehicle that is propelled by an internal combustion engine and was built after 1930.



- (2) The heavy motor vehicle must not emit visible emissions for a continuous period of 10 seconds or more.
- (3) However, this section does not apply to emissions that are visible only because of heat or the condensation of water vapour.

## 96 Exhaust emissions—diesel-powered vehicles

- (1) This section applies to a heavy motor vehicle—
  - (a) powered by a diesel engine; and
  - (b) meeting the criteria for a passenger vehicle including omnibuses and goods vehicles as defined under the ADRs.
- (2) For the purposes of subsection (3), a vehicle is taken to have been manufactured in the month shown on its identification plate as its month of manufacture.
- (3) When a vehicle is tested in accordance with the procedure described in section 97—
  - (a) the vehicle must not emit oxides of nitrogen (NO<sub>x</sub>) at an oxides emission rate greater than that stated for the vehicle according to its GVM rating and age in the following table; and

vehicle's GVM rating (t)	oxides emission rate (g/km/t)	
	<i>Vehicle manufactured in December 1995 or earlier</i>	<i>Vehicle manufactured in January 1996 or later</i>
More than 4.5 but not greater than 12	2.0	2.0
More than 12 but not greater than 25	2.0	1.5
More than 25	1.5	1.2

- (b) the vehicle must not emit particles at a particle emissions rate greater than that stated for the vehicle

according to its GVM rating and age in the following table; and

vehicle's GVM rating (t)	particle emissions rate (g/km/t)	
	<i>Vehicle manufactured in December 1995 or earlier</i>	<i>Vehicle manufactured in January 1996 or later</i>
More than 4.5 but not greater than 12	0.23	0.15
More than 12 but not greater than 25	0.08	0.05
More than 25	0.07	0.03;

(c) the opacity of the exhaust gas emitted by the vehicle must not be greater than 25%, averaged over a DT80 test cycle in the way described or mentioned in the test procedure stated in section 97 that complies with the requirements in section 98.

(4) In this section—

***oxides emission rate*** means the rate measured in grams of NO<sub>x</sub> emitted per kilometre travelled per tonne of the vehicle's test mass.

***particle emissions rate*** means the rate measured in grams of particles emitted per kilometre travelled per tonne of the vehicle's test mass.

***vehicle's test mass*** means—

- (a) if the vehicle is a prime mover—half the sum of its tare mass and its GCM; or
- (b) in any other case—half the sum of its tare mass and its GVM.

*Note*—

The ***vehicle's test mass*** is the load applied to the dynamometer, while the vehicle is under test, to simulate half payload operation.

## 97 Test procedure

For the purposes of section 96(3), the procedure for testing is as follows.

- 
- Step 1** Secure the vehicle on the dynamometer.
- Step 2** Set the dynamometer to simulate the correct load and inertia for the vehicle.
- Step 3** Start sampling.
- Step 4** Idle for 60 seconds.
- Step 5** Accelerate rapidly to 80 km/h under simulated inertia, using wide open throttle, making gear changes as required for smooth acceleration.
- Step 6** Decelerate by removing all pressure from the accelerator pedal, disengaging the gears and gently applying brakes to bring the vehicle to a standstill.
- Step 7** Idle for 10 seconds.
- Step 8** Accelerate rapidly to 80 km/h under simulated inertia, using wide open throttle, making gear changes as required for smooth acceleration.
- Step 9** Decelerate by removing all pressure from the accelerator pedal, disengaging the gears and gently applying brakes to bring the vehicle to a standstill.
- Step 10** Idle for 10 seconds.
- Step 11** Accelerate rapidly to 80 km/h under simulated inertia, using wide open throttle, making gear changes as required for smooth acceleration.
- Step 12** Maintain speed at 80 km/h for 60 seconds, then stop sampling and bring the vehicle to rest.

*Note—*

Explanation of the test procedure

This test has been designed to evaluate vehicle emissions during typical 'real-world' operating modes and conditions. There are 3 simple modes—

- 3 idle periods
- acceleration to 80 km/h 3 times
- maintain speed at 80 km/h.

The graph below indicates the modes of operation. The actual test will result in a graph that has more variation than the indicative graph below,

because of the need to change gears when accelerating. Modes B – D and E – G and H – I have no specific time interval. All the specified time periods have an error margin of  $\pm 1$  second.

The vehicle is accelerated rapidly to 80 km/h 3 times by applying wide open throttle.

The driver selects the most appropriate gear change points for the vehicle being tested to achieve the correct speed.

The vehicle's rolling resistance (based on tyre and bearing losses, frontal area and drag coefficient) must also be calculated and continuously factored into the dynamometer tractive effort calculations to ensure correct loading.

Empirical algorithms, based on vehicle test mass, GVM or other known parameters, may be used to automatically calculate realistic coefficients for these variables.

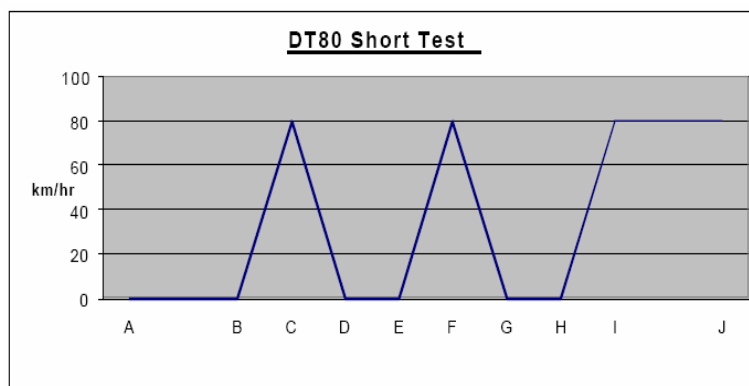

## 98 Requirements of DT80 test cycle

- (1) The requirements stated in the following subsections are the minimum standards for the dynamometer, emissions measurement and data management systems necessary to enable the proper conduct of the DT80 test cycle mentioned in section 96(3)(c).
- (2) The DT80 test cycle must be conducted on a chassis dynamometer system that—
  - (a) can undertake a full throttle transient DT80 test cycle, as described in section 97, for the vehicle being tested; and

- 
- (b) provides for vehicle speed measurement and display, to an accuracy of  $\pm 1\%$  of actual speed; and
  - (c) provides internal steady state accuracy of  $\pm 1\%$  of calculated required tractive load over ambient temperatures of 2<sup>0</sup>–40<sup>0</sup> C; and
  - (d) provides a T95 response time of 3 seconds or less; and
  - (e) provides inertial loading as required by the DT80 protocol at speeds >15 km/h; and
  - (f) compensates for aerodynamic drag, rolling resistance and other parasitic losses; and
  - (g) corrects for ambient temperature, humidity and air density; and
  - (h) provides torque measurement accuracy of better than 1% full scale; and
  - (i) maintains roller speed within  $\pm 10$  km/h through gear changes; and
  - (j) restricts overshoot upon initial acceleration of rollers from rest; and
  - (k) incorporates a driver control panel for remote operation of critical functions from driver's seat, including controls for start test and stop test; and
  - (l) incorporates an emergency system override function; and
  - (m) is able to communicate speed, load and status signals to enable the driver to undertake the test in accordance with the DT80 procedure; and
  - (n) is integrated with the gas and particulate analysis system to initiate the start and finish of sampling and measurement, and generates emission results without the need for post-test processing.
- (3) The emissions measurement system used for the DT80 test cycle must—
- (a) be integrated with the dynamometer system stated in subsection (2); and

- (b) have a data averaging interval of 1 second for all equipment; and
- (c) provide emissions data sampling output  $\leq 5\text{Hz}$ ; and
- (d) measure oxides of nitrogen (from a diluted and conditioned sample) with an accuracy of  $\pm 30\text{ppm}$  over the range 0-1000ppm and  $\pm 5\%$  over the range 1001-5000ppm; and
- (e) measure particulate matter (from diluted sample) as TSP or PM 10 with an accuracy of  $\pm 10\%$  on a real time continuous basis over a range of 0-1000 mg/m<sup>3</sup> actual exhaust concentration at a sample temperature of  $< 51.7^{\circ}\text{C}$ ; and
- (f) measure opacity (from raw exhaust gas sample) with an accuracy of  $\pm 1\%$  over a range of 0-100% opacity; and
- (g) measure flow rate with an accuracy of  $\pm 5\%$ ; and
- (h) measure ambient temperature with an accuracy of  $\pm 1^{\circ}\text{C}$  over a range of 0-50 $^{\circ}\text{C}$ ; and
- (i) measure ambient humidity with an accuracy of  $\pm 5\%$  over a range of 0-100%; and
- (j) compensate/correct for ambient humidity and temperature; and
- (k) compensate for exhaust gas transport times and delays; and
- (l) provide on-line calibration of the analytical system; and
- (m) provide an exhaust sample collection and conditioning system—
  - (i) that is optimised to accommodate the exhaust temperature and flow rate, and emission concentration, for the vehicle being tested; and
  - (ii) that provides adequate conditioning of the exhaust gas to eliminate water in the sample stream and reduce temperatures to enable PM to be sampled at  $< 51.7^{\circ}\text{C}$ ; and

- 
- (n) utilise materials and equipment compatible with the exhaust from diesel fuelled vehicles.
- (4) The data management system used for the DT80 test cycle must—
- (a) be integrated with the dynamometer and emissions measurement systems stated in subsections (2) and (3); and
- (b) record the following items for each test—
- date, time, location and operator
  - emissions analyser calibration data
  - vehicle input data, including test mass tractive load corrections and identifying information
  - dynamometer data on a second by second basis (load, speed, distance)
  - test data on a second by second basis from which a mass emission test result in g/km/t can be generated; and
- (c) display, store and report all data in SI units; and
- (d) provide a system for electronic backup of test data to local and remote media; and
- (e) incorporate a quality control system that—
- (i) ensures calibrations are carried out in accordance with manufacturers' specifications; and
- (ii) provides records consistent with normal audit requirements; and
- (f) print a test report containing at least the following items—
- registered business name, ABN and address of the test facility
  - registration number, make, model, GVM rating and date of manufacture of the tested vehicle
  - date and location of test

- the final calculated NO<sub>x</sub> and PM results in g/km/t
- the final calculated opacity results in %
- a statement of pass or fail for each emission compared to the emission limits stated in section 96
- the signature of the test facility operator confirming that the test was conducted in accordance with the test procedures set out in section 97 and the requirements of this section.

## **Division 2                      Exhaust systems**

### **99                      Exhaust systems**

- (1) The outlet of the exhaust system fitted to a heavy motor vehicle, other than a bus, must extend—
  - (a) behind the back seat; and
  - (b) at least 40mm beyond the outermost joint of the floorpan that is not continuously welded or permanently sealed; and
  - (c) to the edge of the vehicle, if—
    - (i) the vehicle's body is permanently enclosed; and
    - (ii) the vehicle is not fitted with a vertical exhaust system; and
  - (d) no further than the edge of the vehicle at its widest point.
- (2) The outlet mentioned in subsection (1) must discharge the main exhaust flow to the air—
  - (a) if the vehicle is fitted with a vertical exhaust system—
    - (i) at least 150mm above the cab of the vehicle; and
    - (ii) if the outlet discharges the main exhaust flow straight up—
      - (A) at an angle above the horizontal; and



- 
- (B) towards the rear, or to the right, of the vehicle; and
  - (iii) if the outlet does not discharge the main exhaust flow straight up—towards the rear of the vehicle and upwards at an angle within 0° to 45° of the longitudinal axis of the vehicle; or
  - (b) in any other case—
    - (i) less than 750mm above ground level; and
    - (ii) horizontally or downwards at an angle within 0° to 45° of the longitudinal axis of the vehicle; and
    - (iii) towards the rear, or to the right, of the vehicle.
  - (3) An exposed section of a vertical exhaust system fitted to a heavy motor vehicle, other than a bus, must be positioned or shielded to prevent injury to any person.
  - (4) An outlet of the exhaust system fitted to a heavy vehicle that is a bus must—
    - (a) be as near as practicable to the rear of the bus; and
    - (b) extend no further than the edge of the bus at its widest point.
  - (5) The outlet mentioned in subsection (4) must discharge the main exhaust flow to the air—
    - (a) if the bus is fitted with a vertical exhaust system—
      - (i) behind the passenger compartment; and
      - (ii) if the outlet discharges the main exhaust flow straight up—
        - (A) at an angle above the horizontal; and
        - (B) towards the rear, or to the left or right, of the bus; and
      - (iii) if the outlet does not discharge the main exhaust flow straight up—towards the rear of the bus and upwards at an angle within 0° to 45° of the longitudinal axis of the bus; or
    - (b) in any other case—

- (i) horizontally or downwards at an angle within 0° to 45° of the longitudinal axis of the bus; and
  - (ii) towards the rear, or to the right, of the bus.
- (6) If a rain cap is fitted to the outlet of a vertical exhaust system fitted to a heavy motor vehicle, the rain cap must be installed so the hinge of the cap is at an angle of 90° (plus or minus 10°) to the longitudinal axis of the vehicle when viewed from above.
- (7) In this section—  
*vertical exhaust system* means an exhaust system that emits exhaust gases in an upward direction above or near the top of a vehicle to which it is fitted.

## **Division 3            Noise emissions**

### **Subdivision 1        General**

#### **100    Measurement of stationary noise levels**

For the purposes of this Division, the stationary noise level of a heavy motor vehicle must be measured in accordance with the procedure set out for the kind of vehicle in the document entitled 'National Stationary Exhaust Noise Test Procedures for In-Service Motor Vehicles' published by the National Transport Commission in September 2006 as amended from time to time.

#### **101    Meaning of certified to ADR 83/00**

For the purposes of this Division, a vehicle is certified to ADR 83/00 if approval has been given, under section 10A of the Motor Vehicle Standards Act, to place identification plates showing compliance with ADR 83/00 on vehicles of that type.

**102 Silencing device for exhaust systems**

A heavy motor vehicle propelled by an internal combustion engine must be fitted with a silencing device through which all the exhaust from the engine passes.

**Subdivision 2 Noise levels applying to vehicles not certified to ADR 83/00****103 Application of Sdiv 2**

This Subdivision applies to a heavy motor vehicle other than a vehicle certified to ADR 83/00.

**104 Stationary noise levels—other vehicles with spark ignition engines**

- (1) This section applies to a heavy motor vehicle with a spark ignition engine.
- (2) The stationary noise level of the heavy motor vehicle must not be more than the noise level applying to the vehicle under the following table.

Height of outlet of vehicle's exhaust system (mm)	When vehicle built	Noise level (dB(A))
<1500	before July 1983	98
	after June 1983	95
≥1500	before July 1983	94
	after June 1983	91

**105 Stationary noise levels—other vehicles with diesel engines**

- (1) This section applies to a heavy motor vehicle with a diesel engine.

## Schedule 2

- (2) The stationary noise level of the heavy motor vehicle must not be more than the noise level applying to the vehicle under the following table.

<b>Vehicle's GVM (t)</b>	<b>Height of outlet of vehicle's exhaust system (mm)</b>	<b>When vehicle built</b>	<b>Noise level (dB(A))</b>
>4.5 but ≤12	<1500	before July 1980	107
		after June 1980 but before July 1983	104
		after June 1983	101
>12	<1500	before July 1980	109
		after June 1980 but before July 1983	106
		after June 1983	103
>4.5 but ≤12	≥1500	before July 1980	103
		after June 1980 but before July 1983	100
		after June 1983	97
>12	≥1500	before July 1980	105
		after June 1980 but before July 1983	102
		after June 1983	99

---

### **Subdivision 3      Noise levels applying to vehicles certified to ADR 83/00**

#### **106      Stationary noise levels**

The stationary noise level of a heavy motor vehicle certified to ADR 83/00 must not exceed, by more than 5dB(A), the noise level established for the vehicle when it is certified.

## **Part 8                      Alternative fuel systems**

#### **107      LPG-powered vehicles**

- (1) An LPG system installed in a heavy motor vehicle, and the vehicle, must comply with all relevant requirements set out in the version of AS 1425 that was current at the time the system was installed in the vehicle.
- (2) A heavy motor vehicle that has an LPG system installed must have fixed conspicuously to its front and rear number plates the labels required by the version of AS 1425 that was current at the time the system was installed in the vehicle.
- (3) If a heavy motor vehicle had an LPG system installed before AS 1425 was first published, the vehicle must have fixed conspicuously to its front and rear number plates a label that is—
  - (a) made of durable material; and
  - (b) at least 25mm wide and 25mm high; and
  - (c) reflective red conforming with either—
    - (i) AS 1743 ‘Road Signs—Specifications’; or
    - (ii) AS 1906.1 ‘Retroreflective Materials and Devices for Road Traffic Control Purposes—Retroreflective Sheeting’; and

- (d) marked 'LPGAS' or 'LPG', or with similar words or acronyms that have the same meaning, in capital letters at least 6mm high.
- (4) In this section—  
*LPG* means liquefied petroleum gas.

### **108 Vehicles powered by natural gas**

A natural gas system installed in a heavy motor vehicle, and the vehicle, must comply with all relevant requirements set out in the version of AS 2739 that was current at the time the system was installed in the vehicle.

*Examples—*

Forms of natural gas include CNG (Compressed Natural Gas) and LNG (Liquid Natural Gas).

## **Part 9 Maximum road speed limiting**

### **109 Speed limiting**

- (1) A heavy motor vehicle that is a bus built after 1987 with a GVM of more than 14.5t must comply with third edition ADR 65.
- (2) A heavy vehicle that is a prime mover with a GVM of more than 15t that was built after 1987 must comply with third edition ADR 65.
- (3) For the purposes of third edition ADR 65, the maximum road speed capability of a heavy motor vehicle used in a road train is 100km/h.
- (4) This section does not apply to—
  - (a) an emergency vehicle or police vehicle; or
  - (b) a bus fitted with hand grips or similar equipment for standing passengers to hold; or

- (c) a 2-axle prime mover if—
  - (i) it was built after 1987 but before July 1991; and
  - (ii) its owner is a person who uses it for agriculture, horticulture or other primary production activities, other than forestry, fishing and mining.

## **Schedule 3      Vehicle standards applying only to heavy combinations or particular heavy combinations**

section 3

### **Part 1                      Preliminary**

#### **1                      References to combinations, B-doubles and road trains**

In this Schedule—

- (a) a reference to a combination is taken to be a reference to a heavy combination; and
- (b) a reference to a B-double is taken to be a reference to a heavy combination that is a B-double; and
- (c) a reference to a road train is taken to be a reference to a heavy combination that is a road train.

#### **2                      Application to vehicle complying with inconsistent ADR requirement**

- (1) A provision of this Schedule does not apply to a vehicle if the provision is inconsistent with a requirement of a second or third edition ADR that the vehicle complies with, regardless of whether or not the vehicle is required to comply with the requirement.
- (2) However, subsection (1) does not apply if the vehicle is not of the same class or type as a vehicle to which the requirement of the second or third edition ADR applies.
- (3) Also, to avoid doubt, this section does not apply to a requirement of a second or third edition ADR if, and to the extent, a provision of this Schedule expressly provides that the requirement does not apply to a stated vehicle, a vehicle of a stated type or in stated circumstances.



---

**3 Application of provision to heavy vehicle subject of Motor Vehicle Standards Act approval**

A provision of this Schedule does not apply to a vehicle if—

- (a) the vehicle does not comply with a requirement of an ADR applying to the vehicle; and
- (b) the provision corresponds to the requirement of the ADR; and
- (c) despite the noncompliance, approval has been given under section 10A(2) or (3) of the Motor Vehicle Standards Act to place identification plates on vehicles of that type; and
- (d) the vehicle complies with the approval conditions, if any.

**Part 2 General safety requirements****4 Electrical wiring, connections and installations**

- (1) This section applies to a road train longer than 19m that includes a semitrailer, dog trailer or converter dolly.
- (2) The electrical wiring, connections and installations of the semitrailer, dog trailer or converter dolly must comply with third edition ADR 63, whether or not it was built before the day stated in the ADR for vehicles of that type.

**Part 3 Vehicle marking****5 Warning signs for combinations longer than 22m**

- (1) The following combinations must display a road train warning sign at their front and rear—

- (a) a combination longer than 36.5m;
  - (b) a road train longer than 30m that includes 1 or more dog trailers.
- (2) The following combinations must display a road train warning sign at their front and rear, or a long vehicle warning sign at the rear—
- (a) a road train longer than 22m, but not longer than 30m, that includes 1 or more dog trailers;
  - (b) a road train longer than 22m, but not longer than 36.5m, that does not include a dog trailer.
- (3) A combination, other than a road train, longer than 22m, but not longer than 36.5m, must display a long vehicle warning sign at its rear.
- (4) In this section—

*long vehicle warning sign* means a long vehicle warning sign complying with section 6.

*road train warning sign* means a road train warning sign complying with section 6.

## 6 Specifications for warning signs

- (1) This section—
- (a) applies if a road train warning sign or long vehicle warning sign must be fitted to a vehicle under section 5; and
  - (b) prescribes requirements about the warning sign.
- (2) The face of a road train warning sign or long vehicle warning sign must have—
- (a) a yellow surface complying with class 1 or 2 of AS 1906 ‘Retroreflective Materials and Devices for Road Traffic Control Purposes’; and
  - (b) a black border; and
  - (c) its manufacturer’s name or trademark, and the brand and class of material used for the warning sign’s surface,

---

permanently marked in letters no more 10mm high on any visible part of the sign.

- (3) A road train warning sign or long vehicle warning sign must be made of sheet steel 0.8mm thick or another material of at least the same stiffness, unless it is designed to be fitted to a vehicle using an adhesive.
- (4) A road train warning sign or long vehicle warning sign must be at least 1.02m long and at least 250mm high.
- (5) The length of a road train warning sign or long vehicle warning sign may be split into 2 parts, in which case the combined length of its parts must be at least 1.02m long.
- (6) A road train warning sign must show the words 'ROAD TRAIN', and a long vehicle warning sign must show the words 'LONG VEHICLE', in black capital letters, and in typeface Series B(N) complying with AS 1744 'Forms of Letters and Numerals for Road Signs'.
- (7) The letters on a road train warning sign or long vehicle warning sign must be at least 180mm high.
- (8) If the length of a road train warning sign is split into 2 parts, the part fitted on the left must show the word 'ROAD' and the part fitted on the right must show the word 'TRAIN'.
- (9) If the length of a long vehicle warning sign is split into 2 parts, the part fitted on the left must show the word 'LONG' and the part fitted on the right must show the word 'VEHICLE'.
- (10) A road train warning sign or long vehicle warning sign must be fitted horizontally.
- (11) A road train warning sign or long vehicle warning sign must be fitted so—
  - (a) the lower edge of the warning sign is at least 500mm above ground level; and
  - (b) the upper edge of the warning sign is no more than 1.8m above ground level.

- (12) If the length of a road train warning sign or long vehicle warning sign is split into 2 parts, each part must be fitted at the same height as the other.

## **Part 4                      Braking systems**

### **7                      Application of Pt 4 to road trains**

This Part applies in relation to a road train only if the road train is longer than 19m.

### **8                      Braking system design for a prime mover in a B-double**

- (1) A prime mover used in a B-double must comply with second edition ADR 35A or third edition ADR 35.
- (2) A prime mover used in a B-double must also have an anti-lock braking system complying with third edition ADR 64, if the prime mover—
- (a) was built after 1989; or
  - (b) was first used in a B-double after 1993; or
  - (c) is used in a B-double that includes a road tank vehicle carrying dangerous goods.

### **9                      Braking system design for heavy motor vehicles in road trains**

The performance of the braking system of a heavy motor vehicle used in a road train must comply with second edition ADR 35A or third edition ADR 35.

---

**10 Braking system design for heavy trailers in B-doubles or road trains**

- (1) The performance of the braking system of a heavy trailer used in a B-double or road train must comply with second edition ADR 38 or third edition ADR 38.
- (2) A heavy trailer in a road train to which subsection (1) applies need not be fitted with a mechanical parking brake if it carries wheel chocks that provide a performance equal to the performance standard required for a parking brake system.
- (3) A semitrailer, regardless of when it was built, must have an anti-lock braking system complying with third edition ADR 38/01, if—
  - (a) it is being used in a B-double that includes a road tank vehicle, whether or not the semitrailer is itself a road tank vehicle; and
  - (b) the road tank vehicle is carrying dangerous goods.

**11 Air brakes of a heavy motor vehicle in B-doubles or road trains**

- (1) If a heavy motor vehicle used in a B-double or road train is fitted with air brakes that use compressed air, the heavy motor vehicle's braking system must comply with subsections (2) and (3) when—
  - (a) the air pressure in the braking system is measured in an 800mL vessel connected by a 2m pipe with a bore of approximately 13mm to the coupling head of the braking system; and
  - (b) the air pressure before the brakes are applied is not more than—
    - (i) the average of the maximum and minimum pressures in the operating pressure range specified by the vehicle's manufacturer; or
    - (ii) if there is no manufacturer's specification—650kPa.

- (2) The air pressure in the braking system must reach at least 420kPa within 400 milliseconds after the rapid and complete application of the foot-operated brake control.
- (3) After the air brakes have been fully applied, the air pressure in the braking system must fall, within 0.5 seconds after the release of the foot-operated brake control, to 35kPa.
- (4) In this section—  
*coupling head*, of a heavy motor vehicle's braking system, means the part of the braking system that connects the system to a vehicle being towed by the heavy motor vehicle.

## **12 Air brakes in a B-double or road train—least favoured chamber**

- (1) The pressure in the least favoured chamber of the braking system of a heavy motor vehicle used in a B-double or road train that is fitted with air brakes that use compressed air must comply with subsections (2) and (3) when the air pressure before the brakes are applied is not more than—
  - (a) the average of the maximum and minimum pressures in the operating pressure range specified by the vehicle's manufacturer; or
  - (b) if there is no manufacturer's specification—650kPa.
- (2) The pressure must reach at least 420kPa within—
  - (a) for a B-double—1 second after the rapid and complete application of the foot-operated brake control; or
  - (b) for a road train—1.5 seconds after the rapid and complete application of the foot-operated brake control.
- (3) After the brakes have been fully applied, the pressure must fall to 35kPa, or the pressure at which the friction surfaces cease to contact each other, within—
  - (a) for a B-double—1 second after the release of the foot-operated brake control; or
  - (b) for a road train—1.5 seconds after the release of the foot-operated brake control.

(4) In this section—

*least favoured chamber*, in relation to a heavy motor vehicle used in a B-double or road train, means the brake chamber with the longest line to the treadle valve in the heavy motor vehicle.

### 13 Recovery of air pressure for brakes in B-doubles and road trains

(1) The air pressure in each air brake reservoir in a B-double or road train must recover to at least 420kPa within 1 minute after 3 full brake applications have been made within a 10-second period if, before the 3 brake applications have been made—

- (a) the engine is running at maximum speed; and
- (b) the vehicle's governor cut-in pressure is no higher than—
  - (i) the pressure specified by the vehicle's manufacturer; or
  - (ii) if there is no manufacturer's specification—550kPa; and
- (c) the air pressure in the air storage tanks of the vehicle is not more than—
  - (i) the average of the maximum and minimum pressures in the operating pressure range specified by the vehicle's manufacturer; or
  - (ii) if there is no manufacturer's specification—650kPa.

(2) In this section—

*governor cut-in pressure*, in relation to a heavy vehicle, means the air pressure at which the vehicle's air brake compressor starts supplying air to the vehicle's air brake reservoir.

#### **14 Air supply for air brakes in B-doubles and road trains**

- (1) A B-double or road train that uses compressed air to operate accessories must have a compressed air system that—
  - (a) has a compressor with sufficient capacity to ensure that the operation of the accessories does not adversely affect brake performance; and
  - (b) is built to ensure that the vehicle's braking system is preferentially charged.
- (2) In this section—

*compressed air system* means a system for supplying compressed air.

#### **15 Brake line couplings**

- (1) Brake line couplings on the same part of a heavy vehicle in a B-double or road train must not be interchangeable.
- (2) Brake line couplings on a heavy vehicle in a B-double or road train must be polarised in accordance with AS D8-1971 'Hose Couplings for Use with Vacuum and Air-Pressure Braking Systems on Prime Movers, Trailers and Semi-trailers' if the hoses used with the couplings are used for the same purpose as the hoses mentioned in that standard.
- (3) In this section—

*brake line coupling* means a device used to connect equipment between vehicles in a heavy combination for the purpose of ensuring brakes applied to the towing vehicle are also applied to the other vehicles in the combination.

#### **16 Simultaneous parking brake application**

- (1) If the parking brake of a heavy motor vehicle in a B-double or road train is applied, the parking brake of any attached heavy trailer must be applied automatically.
- (2) This section does not apply in relation to a heavy trailer carrying wheel chocks that provide a performance equal to the performance standard required for a parking brake system.



---

**17 Capacity of air reservoirs**

- (1) The capacity of the air storage tanks of a heavy motor vehicle used in a B-double or road train must be at least 12 times the volume of all the brake activation chambers on the heavy motor vehicle.
- (2) The capacity of the air storage tanks of a heavy trailer used in a B-double or road train must be at least 8 times the volume of all the brake activation chambers on the trailer.
- (3) In this section—  
*brake activation chamber*, of a heavy vehicle, means a device that, when air pressure is applied to it, activates another device that applies brakes to the vehicle.

**Part 5 Mechanical connections  
between vehicles in  
combinations****Division 1 Couplings used in all types of heavy  
combination****18 General coupling requirements**

- (1) A fifth wheel coupling, the mating parts of a coupling, a kingpin or a towbar must not be used in a heavy combination for a load more than the manufacturer's load rating.
- (2) A kingpin must be used in a heavy combination only with a fifth wheel coupling that has a corresponding jaw size.

*Example for subsection (2)—*

An adaptor must not be used to fit a kingpin to a fifth wheel coupling.

- (3) The mating parts of a coupling used in a heavy combination to connect a semitrailer to a towing vehicle must not allow the

semitrailer to roll to an extent that makes the towing vehicle unstable.

## **19 Drawbar couplings**

A coupling for attaching a heavy trailer, other than a semitrailer or pole-type trailer, to a towing vehicle in a combination must be built and fitted so that—

- (a) the coupling is equipped with a positive locking mechanism; and
- (b) the positive locking mechanism can be released regardless of the angle of the heavy trailer to the towing vehicle.

## **Division 2 Additional coupling requirements for B-doubles and long road trains**

### **20 Application of Div 2 to road trains**

This Division applies in relation to a road train only if the road train is longer than 19m.

### **21 Couplings for B-doubles and road trains**

- (1) A fifth wheel coupling used to connect a towing vehicle to a semitrailer used in a B-double or road train must not be built with a pivot that allows a semitrailer to roll relative to the towing vehicle.
- (2) However, subsection (1) does not apply to a fifth wheel coupling if—
  - (a) the semitrailer design requires torsional stresses to be minimised; and
  - (b) the roll axis of the fifth wheel coupling is above the surface of the coupler plate of the coupling; and

- (c) the degree of rotation allowed around the roll axis of the fifth wheel coupling is restricted to prevent roll instability.
- (3) A trailer with only 1 axle group or a single axle, other than a semitrailer or a converter dolly, that is used in a road train must not have a coupling fitted at its rear.

## **22 Selection of fifth wheel couplings and turntables for B-doubles and road trains**

- (1) A fifth wheel coupling used in a B-double or road train must have a D-value complying with AS 1773-1990 'Articulated Vehicle—Fifth Wheel Assemblies'.
- (2) A turntable used in a B-double or road train must have a D-value complying with AS 1773-1990 'Articulated Vehicle—Fifth Wheel Assemblies'.
- (3) If a fifth wheel coupling used in a B-double or road train is built for a 50mm kingpin or 90mm kingpin, the coupling must—
  - (a) meet the dimension requirements in AS 1773-1990 'Articulated Vehicle—Fifth Wheel Assemblies'; and
  - (b) not be worn away more than recommended by the standard.
- (4) If a fifth wheel coupling used in a B-double or road train is built for a 75mm kingpin, the coupling must—
  - (a) be compatible with a kingpin built as required by section 25(3)(a); and
  - (b) not be worn so that it does not comply with subsection (5).
- (5) In testing a fifth wheel coupling used in a B-double or road train and built for a 75mm kingpin to decide whether its D-value complies with subsection (1), the longitudinal movement, after readjusting the jaws of the coupling using a kingpin built as required by section 25(3)(a), must not be more than 4mm.

**23 Mounting of fifth wheel couplings on B-doubles and road trains**

A fifth wheel coupling must be mounted on a prime mover, or a semitrailer used in a B-double or road train, in accordance with AS 1771-1987 'Installation of Fifth Wheel and Turntable Assemblies'.

**24 Branding of fifth wheel couplings and turntables on B-doubles and road trains**

- (1) A fifth wheel coupling used in a vehicle built after June 1991 forming part of a B-double or road train must be clearly and permanently marked, in a way complying with AS 1773-1990 'Articulated Vehicles—Fifth Wheel Assemblies', with—
  - (a) the name or trademark of the coupling's manufacturer; and
  - (b) the coupling's D-value rating; and
  - (c) the coupling's nominal size.
- (2) A turntable used in a vehicle built after January 1999 forming part of a B-double or road train must be—
  - (a) clearly and permanently marked with the name or trademark of the turntable's manufacturer; and
  - (b) clearly and permanently marked with the turntable's D-value rating in a way complying with AS 1773-1990 'Articulated Vehicles—Fifth Wheel Assemblies'.

**25 Selection of kingpins for B-doubles and road trains**

- (1) A kingpin used in a B-double or road train must—
  - (a) be a 50mm king pin, 75mm kingpin or 90mm kingpin; and
  - (b) have a D-value complying with AS 2175-1990 'Articulated Vehicles—Kingpins'.
- (2) A 50mm kingpin or 90mm kingpin used in a B-double or road train must—

- (a) be built to meet the dimension requirements in AS 2175-1990 'Articulated Vehicles–Kingpins'; and
  - (b) not be worn away more than recommended by the standard.
- (3) A 75mm kingpin used in a B-double or road train must—
- (a) be built to meet the dimensions in the following diagram; and

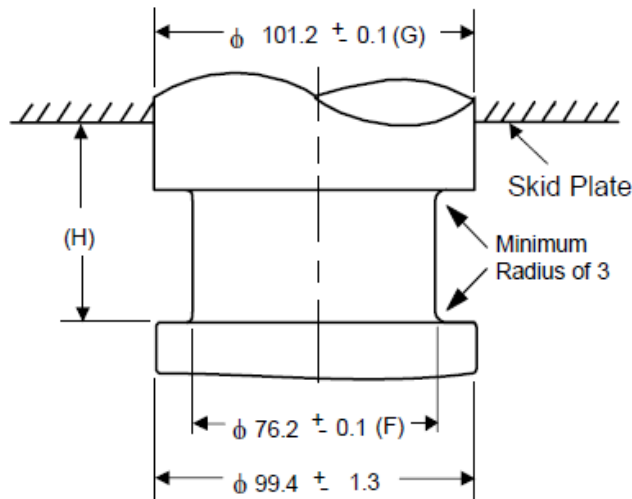

(All Dimensions in Millimetres)

**Dimensions of a 75mm kingpin**

- (b) not be worn away more than mentioned in subsection (4).
- (4) In testing a 75mm kingpin used in a B-double or road train to decide whether its D-value complies with subsection (1)(b)—
- (a) diameter F in the diagram must not wear more than 3mm; and
  - (b) diameter G in the diagram must not wear more than 2mm; and
  - (c) height H in the diagram must not wear more than 2.3mm.

**26 Attachment of kingpins on B-doubles and road trains**

A kingpin used in a trailer that forms part of a B-double or road train must be attached in accordance with—

- (a) the manufacturer's specifications and instructions; or
- (b) AS 2175-1990 'Articulated Vehicles—Kingpins'.

**27 Branding of kingpins on B-doubles and road trains**

A kingpin used in a trailer built after June 1991 that forms part of a B-double or road train must be clearly and permanently marked with the following on the lower circular face of the kingpin, and in a way complying with AS 2175-1990 'Articulated Vehicles—Kingpins'—

- (a) the name or trademark of its manufacturer;
- (b) its D-value rating;
- (c) its nominal size.

**28 Selection of couplings and drawbar eyes for road trains**

A drawbar-type coupling, or drawbar eye, used in a road train must—

- (a) be a 50mm pin type; and
- (b) have a D-value complying with AS 2213-1984 '50 mm Pin-Type Couplings and Drawbar Eyes for Trailers'; and
- (c) be built to the dimensions mentioned in the standard; and
- (d) not be worn away more than is recommended in the standard.

**29 Attachment of couplings and drawbar eyes on road trains**

A drawbar-type coupling, or drawbar eye, used in a road train must be built and positioned so—

- (a) when the road train is moving, the drawbar can move at least 15° upwards or downwards from the position it

- occupies when the road train is parked on level ground;  
and
- (b) the pivot point of the coupling is not more than 300mm forward of the rear of the trailer to which it is attached;  
and
  - (c) it is at a height of at least 800mm, but not more than 950mm, when the road train is unloaded and parked on level ground.

### **30 Branding of couplings and drawbar eyes on road trains**

A drawbar-type coupling, or drawbar eye, used on a vehicle built after June 1991 that forms part of a road train must be clearly and permanently marked, in a way complying with AS/NZS 4968.1:2003 'Heavy Road Vehicle–Mechanical Coupling Between Articulated Vehicle Combinations', with—

- (a) the name or trademark of its manufacturer; and
- (b) its D-value rating.

### **31 Tow coupling overhang on road trains**

- (1) The tow coupling overhang of a heavy motor vehicle, other than a prime mover, used in a road train must not be more than the greater of—
  - (a) 30% of the distance from the centre-line of the front axle to the centre of the axle group, or centre-line of the single axle, at the rear of the vehicle; and
  - (b) 2.7m.
- (2) The tow coupling overhang of a semitrailer, or a dog trailer consisting of a semitrailer and converter dolly, used in a road train must not be more than 30% of the distance from the relevant point of articulation for the trailer to the centre of the axle group, or centre-line of the single axle, at the rear of the trailer.
- (3) The tow coupling overhang of another dog trailer used in a road train must not be more than 30% of the distance from the

centre of the front axle group, or centre-line of the single axle, at the front of the vehicle, to the centre of the axle group, or centre-line of the single axle, at the rear of the vehicle.

- (4) For subsections (1) to (3), a distance between 2 parallel lines must be measured at right angles between the lines.

*Example—*

For the purposes of deciding whether a heavy motor vehicle used in a road train complies with subsection (1), the distance between the centre-line of the vehicle's front axle and the centre of the axle group, or the centre-line of the single axle, at the rear of the vehicle (both of which are vertical lines) must be measured at right angles.

- (5) In this section—

***relevant point of articulation***, in relation to a heavy trailer used in a road train, means the relevant point of articulation for the heavy trailer having regard to how the road train is configured, which may be any of the following—

- (a) the vertical axis of a kingpin used with a fifth wheel coupling;
- (b) the vertical axis of rotation of a fifth wheel coupling;
- (c) the vertical axis of rotation of a turntable;
- (d) for a heavy trailer that is a dog trailer, the vertical axis of rotation of the front axle group or axle of the trailer;
- (e) for a heavy trailer that is a semitrailer, the imaginary vertical line passing through the pivot point for a coupling fitted to the semitrailer.

*Examples—*

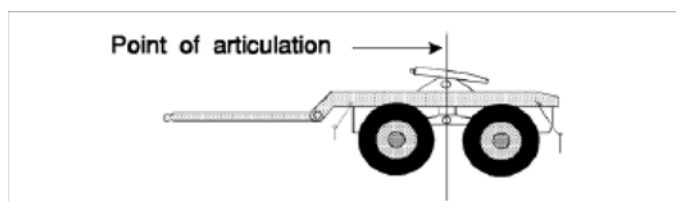

**Point of articulation—fifth wheel coupling on a converter dolly (forming the front axle group of a dog trailer)**



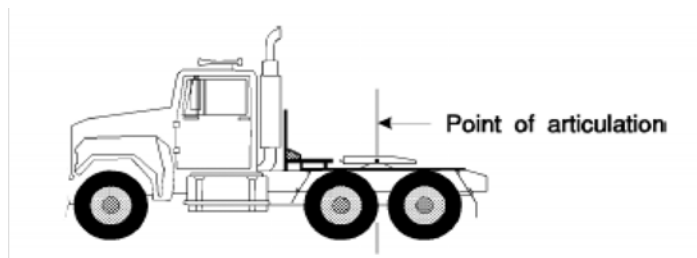

**Point of articulation—fifth wheel on a prime mover**

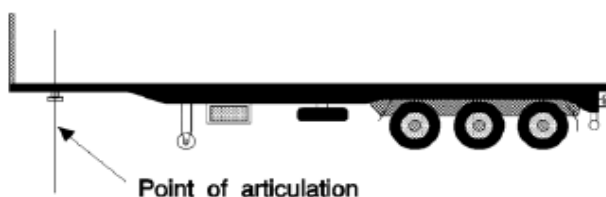

**Point of articulation—kingpin fitted to a fifth wheel coupling**  
*tow coupling overhang*, of a heavy vehicle, means the distance from the centre of the axle group, or the centre-line of the single axle, at the rear of the vehicle to the imaginary vertical line passing through the pivot point of the coupling near the rear of the vehicle.

#### ENDNOTES

- 1 Made by the Queensland Governor, as defined under section 730(5) of the Heavy Vehicle National Law, acting with the advice of the Executive Council of Queensland, on 30 May 2013.
- 2 Published on the NSW legislation website in accordance with Part 6A of the *Interpretation Act 1987* of NSW on 31 May 2013.
- 3 The administering agency is the Heavy Vehicle National Regulator.

© State of Queensland 2013  
Authorised by the Parliamentary Counsel