



Queensland

Transport Operations (Road Use Management) Act 1995

Transport Operations (Road Use Management—Vehicle Registration) Regulation 1999

Reprinted as in force on 1 July 2009

Reprint No. 5B

This reprint is prepared by
the Office of the Queensland Parliamentary Counsel
Warning—This reprint is not an authorised copy

Information about this reprint

This regulation is reprinted as at 1 July 2009. The reprint—

- shows the law as amended by all amendments that commenced on or before that day (Reprints Act 1992 s 5(c))
- incorporates all necessary consequential amendments, whether of punctuation, numbering or another kind (Reprints Act 1992 s 5(d)).

The reprint includes a reference to the law by which each amendment was made—see list of legislation and list of annotations in endnotes. Also see list of legislation for any uncommenced amendments.

This page is specific to this reprint. See previous reprints for information about earlier changes made under the Reprints Act 1992. A table of reprints is included in the endnotes.

Also see endnotes for information about—

- **when provisions commenced**
- **editorial changes made in earlier reprints.**

Spelling

The spelling of certain words or phrases may be inconsistent in this reprint or with other reprints because of changes made in various editions of the Macquarie Dictionary (for example, in the dictionary, ‘lodgement’ has replaced ‘lodgment’). Variations of spelling will be updated in the next authorised reprint.

Dates shown on reprints

Reprints dated at last amendment All reprints produced on or after 1 July 2002, authorised (that is, hard copy) and unauthorised (that is, electronic), are dated as at the last date of amendment. Previously reprints were dated as at the date of publication. If an authorised reprint is dated earlier than an unauthorised version published before 1 July 2002, it means the legislation was not further amended and the reprint date is the commencement of the last amendment.

If the date of an authorised reprint is the same as the date shown for an unauthorised version previously published, it merely means that the unauthorised version was published before the authorised version. Also, any revised edition of the previously published unauthorised version will have the same date as that version.

Replacement reprint date If the date of an authorised reprint is the same as the date shown on another authorised reprint it means that one is the replacement of the other.



Queensland

Transport Operations (Road Use Management—Vehicle Registration) Regulation 1999

Contents

		Page
Part 1	Preliminary	
1	Short title	9
2	Commencement	9
3	Definitions	9
4	Meaning of exempt vehicle	9
4A	Meaning of registered operator in this regulation	11
5	Registered and unregistered vehicles	11
Part 2	Registration principles	
6	Garage address in Queensland	12
7	Persons eligible to register vehicle	12
8	Compliance with vehicle law	12
9	Proof of compliance with vehicle law	12
Part 3	Vehicle registration	
Division 1	Vehicles used on roads must be registered	
10	Vehicles used on roads must be registered	13
Division 2	Conditional registration	
10A	Conditional registration	13
Division 3	Registration generally	
11	Application for registration	15
12	Registration application made by agent	16
12A	Driving or towing unregistered vehicle to place for inspection	16
13	Vehicle inspections	17
14	Determination of applications	19
15	Registered vehicles register	21

Contents

16	Registration certificates	22
17	Registered operator to notify change of particulars	23
18	Recording change in vehicle particulars and reassessment of registration fee	24
19	Registration term	25
20	Seasonal registration	26
21	When registration becomes effective	27
Division 3A	Approval of motorbikes as learner approved motorbikes	
21A	Purpose of div 3A	27
21B	Definition for div 3A	27
21C	Meaning of LAM test report	27
21D	Application for approval of motorbike as a learner approved motorbike	28
Division 4	Number plates	
23	Chief executive to assign registration number and issue number plates	30
24	Position, visibility and legibility of number plate	30
25	Time for attaching number plates	33
26	Q plates	33
27	Personalised number plates	34
28	Transfer of personalised number plate	35
29	Converting number plate to personalised number plate	35
30	Customised number plates	36
31	Accessory plates	36
31A	Accessory plate for tow truck	37
Division 5	Registration labels	
32	Chief executive to issue registration labels	38
33	Position for attaching registration label	39
34	Time for attaching registration label	40
Part 4	Renewal of registration	
36	Registration renewal notice	41
37	Renewal of registration	41
37A	When surcharge is payable for renewal	43
37B	Registration term if overpayment or underpayment of registration-related amount and any surcharge	44
37C	Administrative fee for late payment if cheque dishonoured	45
38	Issue of receipt and updating of records	46

Part 5	Transfer of registration	
39	Transfer of registration	47
40	Failure by dealer to apply for transfer of registration	49
41	Transfer of registration under legal process	50
42	Refusing to register transfer of registration	51
Part 6	Expiry and cancellation of registration	
Division 1	Expiry of registration	
43	Expiry of registration.	51
44	Return of registration plates when registration expires	52
Division 2	Cancellation of registration	
45	Cancellation of registration at registered operator's request	52
45A	Cancellation if registration in other State	54
46	Partial refund of registration fee	54
47	Cancellation for noncompliance with defect notice.	54
48	Cancellation of registration of vehicle or dealer plate.	56
49	Recording cancellation of registration in register	58
Part 7	When registration unnecessary	
Division 1	Unregistered vehicle permits	
50	Unregistered vehicle permits	59
Division 2	Dealer plates	
51	Designation of dealer plates.	60
52	Registration of dealer plate	60
53	Attaching dealer plate.	61
54	Use of dealer plates	62
55	Cancellation of dealer plates	64
Part 7A	Written-off vehicles	
Division 1	Objects of part 7A	
55A	Objects	66
Division 2	Notifying of written-off vehicle information	
55B	General obligations of notifiers	66
55C	Auditing of notifiers.	67
55D	Obligation of notifiers to give notifiable information	67
55E	Obligation of insurer to report written-off vehicle	68
55F	Obligation of self-insurer to report written-off vehicle.	69
55G	Obligation of loss adjuster to report written-off vehicle.	69
55H	Obligation of dealer or auctioneer to report written-off vehicle.	70

Contents

55I	Obligation of auto parts dismantler to report written-off vehicle . . .	71
55J	Obligation of registered operator or owner of unregistered vehicle to report written-off vehicle	72
55K	Notifier’s obligation to tell registered operator or owner	73
55L	Obligation on notifiers to attach written-off vehicle label to written-off vehicle	73
55M	Obligation on registered operator or owner to attach written-off vehicle label to written-off vehicle	74
55N	Offence to remove written-off vehicle label.	75
55O	Written-off vehicles must not be used on road	75
Division 3	Written-off vehicle inspections	
55P	Definition for div 3.	76
55Q	Approvals	76
55R	Conditions of approval	76
55S	Refusing to grant approval	77
55T	Approval prescribed for the Act, ss 17B(2) and 18(1)(c)(ii)	77
Division 4	Offences relating to written-off vehicle inspections	
55U	Performing written-off vehicle inspection when not approved . . .	78
55V	Supervising written-off vehicle inspections when not approved . .	78
55W	Not complying with conditions of approval	78
55X	False or misleading written-off vehicle inspection report	78
55Y	Operating place as a written-off vehicle inspection site	78
55Z	Performing written-off vehicle inspection at place other than written-off vehicle inspection site	79
55ZA	Supervising written-off vehicle inspections at place other than written-off vehicle inspection site	79
55ZB	False advertising or holding out	79
Part 8	General	
Division 1	Other provisions about number plates and other items	
56	Replacement registration items	80
57	Chief executive may require exchange of number plates	81
58	Chief executive may require return of number plates.	82
59	Property in number plates	83
Division 2	Vehicles temporarily in Queensland	
60	Vehicles temporarily in Queensland	83
Division 3	Other miscellaneous provisions	
61	Sale of unregistered vehicles by dealers	85

62	Authorisation to use unregistered vehicle on roads	86
63	Permit to use intercepted unregistered vehicle on road	87
64	Damaged or dirty number plates	88
Division 4	Review of decisions	
65	Decision to which this division applies	89
66	Review of decisions	90
Division 5	Release of information	
67	Definitions for div 5	90
67A	Meaning of history certificate	93
67B	Meaning of status certificate	94
68	Release of information on payment of fee	96
68AA	Release of information to toll road operator, local government tollway operator and other persons	97
68A	Release of vehicle related information	98
68B	Fee or amount payable to vehicle related information provider . .	99
Part 9	Fees	
Division 1	General	
69	Fees	100
70	Charging categories	100
Division 2	Vehicles exempted from registration fees	
71	Exemption from payment of fee	102
Division 3	Concessional registration fees for certain category 1 vehicles	
72	Concessional registration fees—category 1 vehicles	103
Division 4	Concessional registration fees for category 2 vehicles	
73	Concessional registration fees—primary production vehicles . . .	105
74	Concessional registration fee for motorised caravan for card holders	106
75	Concessional registration fees for other vehicles	107
Part 10	Other offence provisions	
76	Offences involving registration certificates etc.	108
77	Requirement to remove unlawful registration item	110
Part 11	Transitional provisions	
Division 1	Transitional provisions for Transport Operations (Road Use Management—Vehicle Registration) Regulation 1999	
78	Purpose of pt 11	111
79	Definition for pt 11	111

Contents

80	Continuation of registration and other authorities under former regulation	111
81	Postponement of particular changes until 31 December 1999. . .	112
82	Limited use plates under former regulation	113
83	Position for attaching registration label to certain trailers	113
Division 2	Transitional provision for written-off vehicle amendments	
84	Registration of vehicle recorded as a written-off vehicle under corresponding law	113
Schedule 1	Category 1 vehicle registration fees	115
Schedule 2	Category 2 vehicle registration fees	118
Schedule 3	Other fees	122
Schedule 3A	Vehicles for particular concessional registration fees	126
1	Special interest vehicle.	126
2	Local government vehicle.	126
3	Community service organisation vehicle	126
4	Vehicle used only in particular areas	126
5	Vehicle used solely to cross roads within an agricultural property	127
6	Vehicle used solely to travel between 2 agricultural properties, or 2 mining properties, directly across the road from each other .	127
7	Vehicle used solely for fencing of primary producer's property . .	128
8	Vehicle used solely as a mobile workshop for carrying on business of bee keeping.	128
9	Vehicle used solely to cross roads within a mining property	128
10	Vehicle used solely to carry on business of oil, mineral or water exploration	128
11	Vehicle used solely for carrying on business of prospecting in particular areas	129
12	Vehicle used solely for carrying on business of well boring	130
Schedule 3B	Areas for schedule 3A, section 11 for category 1 vehicles used solely to carry on business of prospecting	131
Schedule 4	Dictionary	133
 Endnotes		
1	Index to endnotes.	156
2	Date to which amendments incorporated.	156
3	Key	157
4	Table of reprints	157

5	List of legislation	158
6	List of annotations	162

Transport Operations (Road Use Management—Vehicle Registration) Regulation 1999

[as amended by all amendments that commenced on or before 1 July 2009]

Part 1 Preliminary

1 Short title

This regulation may be cited as the *Transport Operations (Road Use Management—Vehicle Registration) Regulation 1999*.

2 Commencement

- (1) Subject to subsection (2), this regulation commences on 1 October 1999.
- (2) Part 8, division 5 and schedule 3, part 2, items 2 to 4 commence on 1 January 2000.

3 Definitions

The dictionary in schedule 4 defines particular words used in this regulation.

4 Meaning of *exempt vehicle*

In this regulation, a vehicle is an *exempt vehicle* if the vehicle is—

- (a) an agricultural implement, if it is being towed by—
 - (i) an agricultural machine suitably matched to the implement; or

[s 4]

- (ii) another vehicle of a suitable size for towing the implement; or
- (b) a trailer being towed by—
 - (i) an agricultural machine that is being used for its intended agricultural purpose; or
 - (ii) a conditionally registered vehicle with limited access registration; or
- (c) a motorised golf buggy or other motorised machinery being used on a golf course or on a golf course car park, or a motorised golf buggy being used for directly crossing a road dividing a golf course; or
- (d) a ride-on mower, other than a ride-on mower that is an agricultural machine, that is being used for mowing, and is—
 - (i) directly crossing a road; or
 - (ii) crossing from 1 road related area to another road related area; or
 - (iii) on a road related area; or
- (e) walking speed equipment that is on a road only for—
 - (i) loading it onto, or unloading it from, another vehicle; or
 - (ii) repositioning it at a work site; or
- (f) a low powered motor vehicle; or
- (g) a vehicle that is not a motor vehicle or a trailer; or
- (h) a vehicle being towed by a tow truck operating as a tow truck; or
- (i) a racing vehicle being used on a racing track or in a related area for a racing track; or
- (j) a motorbike being used in freestyle motocross in a freestyle motocross area; or
- (k) a motorbike being used in an observed trial in an observed trial area; or

- (l) drawn plant being towed by a conditionally registered vehicle of a size suitable for towing the plant.

4A Meaning of *registered operator* in this regulation

- (1) This section defines *registered operator* for its use in this regulation only, and has effect despite the expression's definition in the Act.
- (2) The *registered operator* of a vehicle is the person in whose name the vehicle is currently registered.
- (3) The *registered operator* of a dealer plate is the person in whose name the dealer plate is currently registered.

5 Registered and unregistered vehicles

- (1) In this regulation, a vehicle is taken to be a registered vehicle if it has current registration under this regulation.
- (2) In this regulation, a vehicle is taken to be an unregistered vehicle if—
 - (a) it has no current registration under this regulation because—
 - (i) it has never had registration under this regulation; or
 - (ii) it has had registration under this regulation, but the registration has expired or been cancelled; and
 - (b) nothing in this regulation permits its use on a road, whether or not under limited circumstances.

[s 6]

Part 2 Registration principles

6 Garage address in Queensland

A vehicle may be registered in Queensland only if its garage address is in Queensland.

7 Persons eligible to register vehicle

- (1) Any person may apply to the chief executive to register a category 1 vehicle in the person's name.
- (2) A person may apply to the chief executive to register a category 2 vehicle in the person's name only if the person is a corporation or an individual aged 18 or over.

8 Compliance with vehicle law

To be eligible for registration, other than conditional registration, a vehicle must conform with the requirements applying to the vehicle under each vehicle law.

9 Proof of compliance with vehicle law

- (1) The chief executive may accept as evidence that a vehicle conforms with the requirements applying to the vehicle under a vehicle law—
 - (a) a plate attached to the vehicle under the vehicle law; or
 - (b) a written statement to that effect from the vehicle's manufacturer.
- (2) In the absence of evidence mentioned in subsection (1), the chief executive may, on inspecting the vehicle and being satisfied it conforms with the requirements applying to the vehicle under each vehicle law, issue a certificate to that effect.

Part 3 Vehicle registration

Division 1 Vehicles used on roads must be registered

10 Vehicles used on roads must be registered

A person must not use, or permit to be used, on a road a vehicle that is not a registered vehicle unless—

- (a) under section 12A or 13, the vehicle is being driven or towed to where it is to be inspected; or
- (b) the vehicle is being used under an unregistered vehicle permit under section 50; or
- (c) the vehicle is being used under the authority of a dealer plate under section 52; or
- (d) the use of the vehicle on the road is authorised under section 60; or
- (e) the vehicle is being used under an authorisation issued under section 62; or
- (f) the vehicle is being used under a permit issued under section 63; or
- (g) the vehicle is an exempt vehicle.

Maximum penalty—80 penalty units.

Division 2 Conditional registration

10A Conditional registration

- (1) This section applies to a vehicle if—
 - (a) there is a guideline under the Road Use Management Regulation, section 48 for the safe movement of the vehicle, or vehicles of its type, on a road (a *safe movement guideline*); and

[s 10A]

- (b) the vehicle—
 - (i) does not conform with the requirements applying to the vehicle under a vehicle law; or
 - (ii) is used primarily for off-road use but is used occasionally, or has restricted use, on a road.

Example of paragraph (b)(ii)—

A farmer owns separate paddocks a short distance apart adjoining a road and drives a vehicle on the road to take it from one paddock to another.

- (2) The chief executive may, on application under section 11, register the vehicle (***conditional registration***) with 1 of the following—
 - (a) limited access registration;
 - (b) zone access registration;
 - (c) unrestricted access registration.
- (3) However, the chief executive must not register the vehicle unless the chief executive is satisfied the vehicle conforms with the safe movement guideline.
- (4) A person who uses a conditionally registered vehicle must comply with the conditions for use applying to the vehicle that are stated in the safe movement guideline.

Maximum penalty—30 penalty units.

- (5) A person must not permit a conditionally registered vehicle to be used on a road unless the conditions for use applying to the vehicle that are stated in the guideline allow the vehicle to be used on the road.

Maximum penalty—30 penalty units.

Division 3 Registration generally

11 Application for registration

- (1) An application for the registration of a vehicle must be made to the chief executive in the approved form accompanied by the following—
 - (a) any relevant registration fee;
 - (b) any registration administration fee for a conditionally registered vehicle;
 - (c) any relevant plate fee;
 - (d) if the vehicle is a category 1 vehicle, the category 1 vehicle traffic improvement fee;
 - (e) if the vehicle is a category 2 vehicle, other than a trailer, the category 2 registration administration fee;
 - (f) an insurance certificate under the *Motor Accident Insurance Act 1994* for the vehicle for the proposed registration term or the insurance premium payable under that Act for the certificate;
 - (g) if the vehicle is a COI vehicle under the Vehicle Standards and Safety Regulation, a current certificate of inspection under that regulation for the vehicle, but only if, once the vehicle is registered, its owner will be required under that regulation to possess a current certificate of inspection for the vehicle;
 - (h) if the vehicle is an SC vehicle under the Vehicle Standards and Safety Regulation, a current safety certificate under that regulation, unless—
 - (i) the garage address of the vehicle is in an area mentioned in schedule 2, item 4 or 5 of the Vehicle Standards and Safety Regulation; or
 - (ii) the vehicle has never previously been registered in Queensland, in another State or in a foreign country; or

[s 12]

- (iii) the vehicle is being registered in the name of a dealer for resale purposes;
 - (i) any duty payable under the *Duties Act 2001*;
 - (j) if applicable, a gas certificate for each gas system in the vehicle.
- (2) A vehicle mentioned in subsection (1)(g) or (h) must be taken with the application to the place where the application is to be given to the chief executive.

12 Registration application made by agent

- (1) This section applies if the application of a person (the ***applicant***) to register a vehicle is made by another person (the ***agent***) as agent for the applicant.
- (2) The chief executive must not grant the application unless the agent gives the chief executive satisfactory evidence of—
- (a) the agent's identity; and
 - (b) the applicant's identity; and
 - (c) the agent's authority to act as agent for the applicant to register the vehicle.

12A Driving or towing unregistered vehicle to place for inspection

- (1) This section applies if it is necessary, for registering an unregistered vehicle under this regulation, for the vehicle to be driven or towed to—
- (a) an AIS under the Vehicle Standards and Safety Regulation for inspection for obtaining an inspection certificate under that regulation; or
 - (b) if the vehicle is a vehicle that is recorded in the register as a repairable write-off, a written-off vehicle inspection site for obtaining a written-off vehicle inspection report; or
 - (c) another place as required by the chief executive.

Examples for paragraph (c)—

- a place for inspecting by the Queensland Police Service
 - a place for road testing by an inspection station
 - a place for having an identifying number stamped
 - a place for obtaining a gas certificate or for obtaining a measurement ticket
- (2) The vehicle may be driven or towed to the place and subsequently to an office of the chief executive where it may be registered, but only if—
- (a) an application in the approved form to register the vehicle has been completed; and
 - (b) if the vehicle is required to be insured under the *Motor Accident Insurance Act 1994*, a current insurance certificate has been issued for the vehicle; and
 - (c) the documents mentioned in paragraphs (a) and (b) are—
 - (i) for a trailer—carried in the motor vehicle towing the trailer; or
 - (ii) for another vehicle—carried in the vehicle.

13 Vehicle inspections

- (1) The chief executive may require a vehicle to be brought to the chief executive for an inspection—
- (a) before the vehicle is registered under this regulation; or
 - (b) if the vehicle is recorded in the register as a repairable write-off, before the chief executive changes the register to ensure the vehicle is no longer recorded as a repairable write-off.
- (2) Subsection (3) applies if, when the chief executive inspects the vehicle—
- (a) an identifying number placed on the vehicle by the vehicle's manufacturer is not clearly legible or appears to have been altered or defaced; or

[s 13]

- (b) for a vehicle recorded in the register as a repairable write-off that has been repaired, the vehicle no longer has an identifying number.
- (3) The chief executive—
 - (a) may allot a replacement identifying number for the vehicle; and
 - (b) must record the allotted replacement identifying number in the register.
- (4) The applicant must, as soon as practicable—
 - (a) take action to obtain the necessary permission under section 134 of the Act to stamp the allotted replacement identifying number on the vehicle; and
 - (b) if the permission is obtained, ensure the allotted replacement identifying number is stamped on the vehicle.

Maximum penalty—8 penalty units.

- (5) The obligation to which the applicant is subject under subsection (4) continues to apply even if the applicant does not further pursue the registration of the vehicle.
- (6) Subsection (7) applies if, after the vehicle is registered or, for a vehicle that was recorded in the register as a repairable write-off, after the chief executive has changed the register to ensure the vehicle is no longer recorded as a repairable write-off, it appears to the chief executive that there is a possible discrepancy relating to the particulars of the vehicle as registered.
- (7) The registered operator of the vehicle must, if requested by written notice from the chief executive, return the vehicle for further inspection.

Maximum penalty for subsection (7)—8 penalty units.

14 Determination of applications

- (1) The chief executive may refuse an application for the registration of a vehicle if the chief executive reasonably believes—
 - (a) the vehicle or a part of the vehicle is, or may be, stolen; or
 - (b) information given in the application is false or misleading; or
 - (c) the vehicle's chassis number or VIN is the same as the chassis number or VIN of a vehicle recorded in the register, or in a register kept under a corresponding law to this regulation, as a statutory write-off; or
 - (d) the vehicle's chassis number or VIN is the same as the chassis number or VIN of a vehicle recorded in the register as a repairable write-off, unless there is a written-off vehicle inspection report for the vehicle; or
 - (e) the vehicle's chassis number or VIN is the same as the chassis number or VIN of a vehicle recorded in a register kept under a corresponding law to this regulation as a repairable write-off, unless there is a written-off vehicle inspection report for the vehicle or, under the corresponding law, there is a report for the vehicle that is equivalent to a written-off vehicle inspection report; or
 - (f) a person, by giving or purporting to give under this regulation a written-off vehicle inspection report for the vehicle, has committed an offence; or
 - (g) a person, by giving or purporting to give under a corresponding law to this regulation a report that is equivalent to a written-off vehicle inspection report for the vehicle, has committed an offence; or
 - (h) an approved examiner under the Vehicle Standards and Safety Regulation has, by issuing an inspection certificate for the vehicle under that regulation, contravened the Act; or

[s 14]

- (i) there are unpaid fines or penalties arising out of the use of the vehicle in Queensland or another State; or
 - (j) the vehicle's garage address is in another State; or
 - (k) the vehicle does not conform with the requirements applying to the vehicle under a vehicle law; or
 - (l) the vehicle has been registered in another State and—
 - (i) the registration in the other State has been suspended or cancelled for a reason other than its expiry; and
 - (ii) the reasons for the cancellation or suspension still exist.
- (2) Subsection (1) does not limit the chief executive's power to refuse the application under another provision of this regulation.
- (2A) Despite subsection (1), the chief executive may decide that a written-off vehicle inspection report is not required for a vehicle that is recorded in the register, or in a register kept under a corresponding law to this regulation, as a repairable write-off.

Example—

The chief executive decides the damage to a vehicle is limited to cosmetic damage.

- (3) If the chief executive decides to grant the application, the chief executive must register the vehicle in the applicant's name.
- (4) If the chief executive decides to refuse the application, the chief executive must tell the applicant—
 - (a) the reasons for the refusal; and
 - (b) that the decision may be reviewed under section 66, unless the vehicle's chassis number or VIN is the same as the chassis number or VIN of a vehicle recorded in the register, or in a register kept under a corresponding law to this regulation, as a statutory write-off.

-
- (5) If asked by the applicant, the chief executive must give written reasons for refusing the application.

15 Registered vehicles register

- (1) The chief executive must keep a register of registered vehicles (the *register*).
- (2) The register must contain the following particulars for each registered vehicle, to the extent the particulars are applicable for the vehicle—
- (a) the registered operator's name;
 - (b) the vehicle's registration number and other identification details;
 - (c) the vehicle's GVM or GCM;
 - (d) the vehicle's garage address;
 - (e) the registered operator's address;
 - (f) for a conditionally registered vehicle, the conditions for use applying to the vehicle that are stated in the safe movement guideline;
 - (g) the commencement and expiry days for the registration;
 - (h) for a category 2 vehicle—the vehicle's nominated configuration;
 - (i) for a motorbike, other than a motorbike that is conditionally registered—whether the motorbike is a learner approved motorbike.
- (3) The chief executive must ensure the register contains the particulars of each vehicle that—
- (a) is currently registered; or
 - (b) is not currently registered, but has been a registered vehicle within the previous 2 years.
- (4) The register must also contain the notifiable information about a written-off vehicle notified under part 7A, whether or not the vehicle is currently registered.

[s 16]

- (5) However, subsection (6) applies if—
- (a) for a vehicle recorded in the register as a repairable write-off, there is a written-off vehicle inspection report for the vehicle; or
 - (b) for a vehicle recorded in a register kept under a corresponding law to this regulation, there is under the corresponding law a report for the vehicle that is equivalent to a written-off vehicle inspection report.
- (6) The chief executive must change the register to ensure the vehicle is no longer recorded as a repairable write-off.
- (7) The chief executive may record in the register other information—
- (a) required to be recorded under the Act or another Act; or
 - (b) the chief executive decides is appropriate.

Examples of information the chief executive could decide to record under subsection (7)(b)—

- 1 odometer readings to help in consumer protection
- 2 pension details for managing concessional registration schemes

- (8) Despite anything else in this regulation—
- (a) the chief executive is not required to make sure that the person whose name is shown in the register as the registered operator of a vehicle is a person who has title to the vehicle; and
 - (b) the register is not intended to be a means by which the title to a registered vehicle may be conclusively established.

16 Registration certificates

- (1) If the chief executive registers a vehicle, the chief executive must issue a registration certificate to the applicant for the vehicle.

-
- (2) The certificate must include the following particulars, to the extent the particulars are applicable for the vehicle—
- (a) the registered operator's name and address;
 - (b) the vehicle's garage address;
 - (c) the vehicle's registration number;
 - (d) the make of the vehicle;
 - (e) the vehicle's VIN or, if there is no VIN, the vehicle's chassis number or engine number;
 - (f) the vehicle's GCM or GVM;
 - (g) the vehicle charging category;
 - (h) the commencement and expiry days for the registration;
 - (i) if the vehicle is a conditionally registered vehicle, the conditions for use applying to the vehicle that are stated in the safe movement guideline;
 - (j) a separate code, for example a letter of the alphabet, for each of the conditions.
- (3) The chief executive may also include in the certificate any other information the chief executive decides appropriate.

17 Registered operator to notify change of particulars

- (1) The registered operator of a vehicle must, within 14 days after the person's address, or the garage address of the vehicle, is changed, give the chief executive full particulars of the change.

Maximum penalty—8 penalty units.

- (2) The registered operator of a vehicle must, within 14 days after the person's name is changed, give the chief executive—
- (a) written notice containing full particulars of the change; and
 - (b) suitable material in writing evidencing the change.

Maximum penalty—8 penalty units.

[s 18]

- (3) If a person modifies a registered vehicle, the registered operator of the vehicle must give the chief executive written notice containing full particulars of the modification within 14 days after the modification.

Maximum penalty—8 penalty units.

- (4) The registered operator must not use the vehicle on a road until the chief executive has been notified of the modification, and any additional registration fee or charge attributable to the modification has been paid to the chief executive, if—
- (a) the vehicle is a category 2 vehicle; and
 - (b) at least 1 of the following applies—
 - (i) the modification is to the vehicle’s description as recorded in the register;
 - (ii) because of the modification, the registration fee applicable to the vehicle is higher than the fee paid for its current registration.

Maximum penalty—80 penalty units.

- (5) In this section—

modifies a registered vehicle means modifies any of the following—

- (a) the vehicle’s axle configuration;
- (b) the vehicle’s carrying capacity;
- (c) the vehicle’s description as recorded in the register;
- (d) the method of propulsion of the vehicle;
- (e) the vehicle’s GCM or GVM;
- (f) any other particular of the vehicle recorded in the register.

18 Recording change in vehicle particulars and reassessment of registration fee

- (1) If the chief executive is satisfied the particulars given under section 17 are correct, the chief executive must—

-
- (a) record the correct name, address or particulars in the register; and
 - (b) issue an updated registration certificate; and
 - (c) if the details on the registration label issued for the vehicle have changed, issue a replacement registration label.
- (1A) However, the chief executive must not act under subsection (1) to record an identifying number of a vehicle that is recorded in the register as a written-off vehicle, other than if the chief executive allots a replacement identifying number for the vehicle under section 13.
- (2) Also, if the particulars are for the modification of a vehicle, the chief executive may reassess the registration fee payable for the vehicle for the term (the *unexpired term*) from when the vehicle was modified to the end of the vehicle's current registration.
 - (3) The chief executive must as soon as practicable refund to the registered operator any amount by which the reassessed fee is less than the fee already paid for the unexpired term.
 - (4) The chief executive may, by written notice given to the registered operator, require the registered operator to pay any amount by which the reassessed fee is more than the fee already paid for the unexpired term within 28 days after the notice is given.
 - (5) The registered operator must comply with the requirement unless the registered operator has a reasonable excuse.

Maximum penalty for subsection (5)—60 penalty units.

19 Registration term

A vehicle may be registered for the term asked for by the applicant from the following terms—

- (a) 1 year;
- (b) 6 months;
- (c) if the vehicle is a category 2 vehicle, 3 months;

[s 20]

- (d) another term the chief executive considers reasonable and appropriate, having regard to the administrative needs of the applicant.

20 Seasonal registration

- (1) A vehicle owned by a primary producer may be registered for 3 or 6 months if it is used only in the registered operator's business as a primary producer.
- (2) A vehicle used only seasonally may be registered for 3 or 6 months if it is used only to transport primary produce from a farm or fishing waters to where the primary produce is—
 - (a) loaded onto a train, vessel or another vehicle; or
 - (b) stored before being processed; or
 - (c) the subject of the first processing step applied to it; or
 - (d) processed.
- (3) At the end of the registration term, the registration of a vehicle under subsection (1) or (2) may be—
 - (a) renewed for 3 months or 6 months; or
 - (b) deferred for not longer than 1 year and then renewed.
- (4) Subsection (3) does not stop the registration of a vehicle being—
 - (a) renewed for a term for which vehicles are usually registered under section 19; or
 - (b) cancelled under part 6.
- (5) In this section—

vehicle means—

 - (a) a prime mover or truck with a GVM of 6t or over 6t; or
 - (b) a trailer with an MRC over 4.5t.

21 When registration becomes effective

The registration of a vehicle is effective on the issue of the chief executive's receipt for payment.

Division 3A Approval of motorbikes as learner approved motorbikes

21A Purpose of div 3A

The purpose of this division is to enable a person to apply to the chief executive for the approval of a particular motorbike as a learner approved motorbike.

Note—

This application process may be used if a particular bike is not stated to be a learner approved motorbike in the list of learner approved motorbikes kept by the chief executive.

21B Definition for div 3A

In this division—

LAM information, for a motorbike, means the following information about the motorbike—

- (a) engine capacity;
- (b) maximum engine power;
- (c) tare mass.

21C Meaning of ***LAM test report***

- (1) A ***LAM test report*** is documentation showing the results of 1 or more tests conducted on a motorbike to work out the LAM information for an application for approval of the motorbike under section 21D.

Example of LAM test report—

a printout of the results of a test from a vehicle testing facility and a printout of the results of a test by a weighbridge

[s 21D]

- (2) A test mentioned in subsection (1) may be conducted by 1 or more entities or persons.
- (3) A LAM test report must contain the following information about a test conducted on a motorbike—
 - (a) the name and address of the entity or person who conducted the test;

Examples of an entity for subsection (3)(a)—

a vehicle testing facility or a weighbridge

- (b) the date of the test;
- (c) the LAM information;
- (d) details about the measuring system used to conduct the test.

Example of measuring system for subsection (3)(d)—

a dynamometer or a similar measuring system that is designed to measure power produced by an engine

21D Application for approval of motorbike as a learner approved motorbike

- (1) A person may apply to the chief executive for approval of a production motorbike as a learner approved motorbike.
- (2) The application must—
 - (a) be in the approved form; and
 - (b) be accompanied by—
 - (i) a copy of a document published by the motorbike's manufacturer showing the LAM information (the ***manufacturer's document***) for the motorbike; or
 - (ii) if a copy of the manufacturer's document is unavailable or does not provide the LAM information for the motorbike—a LAM test report; and
 - (c) to the extent the information is available to the applicant, include the following information about the motorbike—

- (i) make and model;
 - (ii) year of manufacture;
 - (iii) engine number;
 - (iv) VIN or chassis number.
- (3) The chief executive may grant the application only if the chief executive is satisfied that—
- (a) for a motorbike with an internal combustion engine—the engine capacity for the motorbike is not more than 660mL; and
 - (b) the power to weight ratio for the motorbike is not more than 150kW per tonne; and
 - (c) any modifications to the motorbike are allowable modifications.
- (4) If the chief executive decides to grant the application, the chief executive must—
- (a) record the motorbike in the register as a learner approved motorbike; and
 - (b) issue a registration label for the motorbike which indicates the motorbike is a learner approved motorbike; and
 - (c) record the motorbike in the list of learner approved motorbikes kept by the chief executive.
- (5) However, the chief executive is not required to do the things mentioned in subsection (4)(a) and (b) if the motorbike is conditionally registered.
- (6) If the chief executive decides to refuse the application, the chief executive must tell the applicant—
- (a) the reasons for the refusal; and
 - (b) that the decision may be reviewed under section 66.
- (7) If asked by the applicant, the chief executive must give written reasons for refusing the application.

[s 23]

Division 4 Number plates

23 Chief executive to assign registration number and issue number plates

- (1) If the chief executive registers a vehicle, the chief executive must—
 - (a) assign a distinguishing registration number to the vehicle; and
 - (b) issue to the registered operator of the vehicle the number plates displaying the assigned number required under subsection (2).
- (2) The chief executive must issue—
 - (a) if the vehicle is a motorbike, motorised wheelchair, quad bike or trailer—1 number plate; or
 - (b) if the vehicle is a vehicle other than a vehicle mentioned in paragraph (a)—2 number plates.

24 Position, visibility and legibility of number plate

- (1) The registered operator of a vehicle must ensure that each number plate issued for a vehicle is permanently attached to the vehicle so that, if the vehicle is on level ground—
 - (a) the number plate is—
 - (i) in an upright position parallel to the vehicle's axles; and
 - (ii) not more than 1.3m above ground level; and
 - (b) unless an accessory plate is attached to the vehicle in the way required under section 31, the characters on the number plate are visible from 20m away at any point within an arc of 45 degrees from the surface of the number plate above or to either side of the vehicle, in the way shown in figures 1 and 2 at the end of this section; and
 - (c) any cover on the number plate—

-
- (i) is clear, clean, untinted and flat over its entire surface; and
 - (ii) has no reflective or other characteristics that would prevent—
 - (A) the successful operation of a photographic detection device; or
 - (B) the number plate from being legible; and
 - (d) the number plate is in a clearly legible condition, including being clearly legible from any position from which it is required to be visible.

Maximum penalty—40 penalty units.

- (1A) A load on the vehicle is taken to make the characters not visible contrary to subsection (1)(b) if the load—
 - (a) makes the characters not visible or only partly visible; or
 - (b) obscures the characters.
- (2) The registered operator must also ensure that—
 - (a) if the vehicle has been issued with 2 number plates—1 number plate is attached to the front of the vehicle and the other to its rear; or
 - (b) if the vehicle has been issued with only 1 number plate—the number plate is attached to its rear.

Maximum penalty—12 penalty units.

- (3) The registered operator does not contravene subsection (1)(a) or (b) if—
 - (a) it is not practicable to attach a number plate to the vehicle in the way required under subsection (1)(a) or (b) because of the vehicle's construction; and
 - (b) the registered operator attaches the number plate to the vehicle as nearly as practicable in the way required under subsection (1)(a) or (b).
- (4) The registered operator does not contravene subsection (1)(b) if the position for the rear number plate of the vehicle (the

[s 24]

towing vehicle) is obscured by another vehicle (the *towed vehicle*) being towed by the towing vehicle and any of the following applies—

- (a) the towed vehicle is registered under this regulation or a corresponding law to this regulation, and displays its rear number plate in the way required under subsection (1) or under the corresponding law;
 - (b) the towing vehicle is a tow truck, the towed vehicle is not registered under this regulation or a corresponding law to this regulation, and the towed vehicle—
 - (i) displays the towing vehicle's rear number plate in a way consistent with the requirements of subsection (1); or
 - (ii) displays an accessory plate for the towing vehicle in the way required under section 31A(5);
 - (c) the towing vehicle is not a tow truck, the towed vehicle is an exempt vehicle under section 4(a), (b) or (l) when being towed by the towing vehicle and the towed vehicle displays the towing vehicle's rear number plate in a way consistent with the requirements of subsection (1) or under a corresponding law to this regulation.
- (5) In this section—

number plate does not include an accessory plate issued under section 31.

photographic detection device has the meaning given by the *Transport Operations (Road Use Management) Act 1995*, section 113.

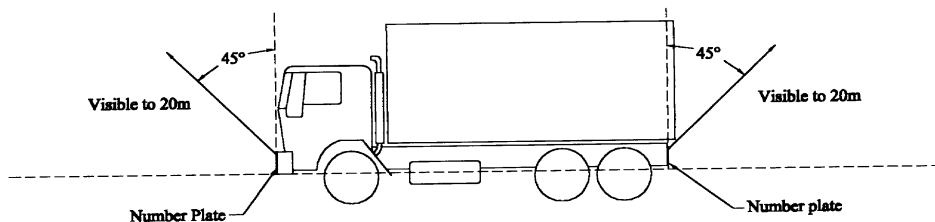

Figure 1

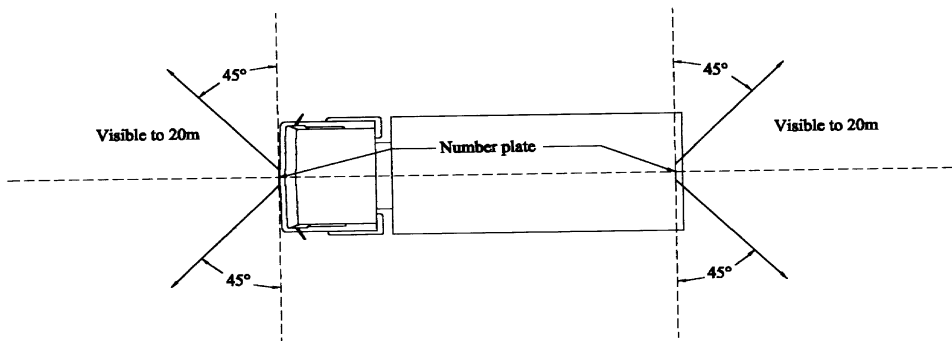

Figure 2

25 Time for attaching number plates

- (1) The registered operator of a vehicle must attach to the vehicle a number plate issued for the vehicle within 1 day after receiving the number plate.

Maximum penalty—12 penalty units.

- (2) The registered operator of a vehicle must attach to the vehicle a special plate the registered operator holds for the vehicle within 1 day after receiving a registration certificate showing the number of the special plate as the registration number of the vehicle.

Maximum penalty—12 penalty units.

26 Q plates

- (1) A person must not manufacture a replacement Q plate unless the person—
 - (a) has written approval from the chief executive to manufacture the plate; and
 - (b) manufactures the plate under the specifications for the plate stated in the approval.

Maximum penalty—12 penalty units.

- (2) A replacement Q plate manufactured under subsection (1) is taken to have been issued by the chief executive.

[s 27]

(3) In this section—

Q plate means a number plate the number of which consists of the letter ‘Q’ followed by at least 1, but not more than 6, figures.

27 Personalised number plates

- (1) The chief executive may issue a number plate as a personalised number plate—
 - (a) on receipt of—
 - (i) an application in the approved form; and
 - (ii) an amount determined by the chief executive; or
 - (b) on a sale at public auction for an amount acceptable to the chief executive.
- (2) When the chief executive issues a personalised number plate, the chief executive must—
 - (a) assign a registration number; and
 - (b) record information relating to the plate in the register; and
 - (c) issue to the applicant a certificate stating the particulars of the plate.
- (3) The right to use the number on a personalised number plate issued to a person is the property of the person to whom the plate is issued.
- (4) A personalised number plate may be—
 - (a) kept without being attached to a vehicle; or
 - (b) subject to subsection (5), attached to a vehicle; or
 - (c) surrendered to the chief executive for cancellation.
- (5) A person must not attach a personalised number plate to a vehicle until the person has—
 - (a) applied to the chief executive in the approved form; and

- (b) received a registration certificate showing the number of the personalised number plate as the registration number for the vehicle.

Maximum penalty—12 penalty units.

- (5A) A personalised number plate must be attached to a vehicle under any directions given by the chief executive.

Maximum penalty—12 penalty units.

- (6) The chief executive must not issue a personalised number plate if the number of the plate is identical, or appears to be identical, to the number of another number plate that is currently issued.
- (7) If a person surrenders a personalised number plate to the chief executive for cancellation, subsection (3) no longer applies to the personalised number plate.

28 Transfer of personalised number plate

- (1) A personalised number plate, including the right to use the number on the personalised number plate, is transferable.
- (2) A person to whom a personalised number plate is transferred, including a person administering an estate, must within 14 days after the transfer—
 - (a) notify the chief executive of the transfer in writing; and
 - (b) pay the relevant fee.

Maximum penalty—16 penalty units.

- (3) A person must not transfer a personalised number plate on its own if it is one of a pair.

Maximum penalty—16 penalty units.

29 Converting number plate to personalised number plate

A person may, on payment of an amount decided by the chief executive, apply to the chief executive to convert a number plate to a personalised number plate.

[s 30]

30 Customised number plates

- (1) The registered operator of a vehicle may apply to the chief executive to customise the vehicle's number plate or a previously issued number plate.
- (2) Once the number plate has been customised, the registered operator may—
 - (a) keep the number plate without attaching it to a vehicle; or
 - (b) apply to the chief executive in the approved form to attach it to a vehicle owned by the registered operator.
- (3) A person must not attach a customised number plate to a vehicle unless—
 - (a) the chief executive gives the person a registration certificate showing the number of the customised number plate as the registration number for the vehicle; and
 - (b) the customised number plate is attached to the vehicle under any directions given by the chief executive.

Maximum penalty—12 penalty units.

31 Accessory plates

- (1) This section applies if the chief executive has issued a special plate to a person.
- (2) The person may apply to the chief executive for an accessory plate for an accessory that is to be attached to a vehicle to which the special plate may be attached.
- (3) The accessory plate must display the same registration number as the special plate.
- (4) The application must be in the approved form and accompanied by the relevant fee.
- (5) If the chief executive decides to issue the plate, the chief executive must issue the plate as soon as convenient after the plate has been prepared.

-
- (6) A person who attaches an accessory plate to the front of a vehicle must attach the plate—
- (a) at the front of the accessory; and
 - (b) in a way that allows the accessory plate to be legible from a distance of at least 20m from the front of the accessory.

Maximum penalty—12 penalty units.

- (7) A person who attaches an accessory plate to the rear of a vehicle must attach the plate—
- (a) at the rear of the accessory; and
 - (b) in a way that allows the accessory plate to be legible from a distance of at least 20m from the rear of the accessory.

Maximum penalty—12 penalty units.

- (8) In this section—

accessory means a bike rack or other device attached to the front or rear of a vehicle in a way that—

- (a) makes the vehicle's front or rear number plate not visible or only partly visible; or
- (b) obscures the vehicle's front or rear number plate.

31A Accessory plate for tow truck

- (1) The registered operator of a tow truck may apply to the chief executive for an accessory plate to be attached to unregistered vehicles when towed by the tow truck.
- (2) The accessory plate must display the same registration number as each number plate for the tow truck.
- (3) The application must be in the approved form and accompanied by the relevant fee.
- (4) If the chief executive decides to issue the plate, the chief executive must issue the plate as soon as convenient after the plate has been prepared.

[s 32]

- (5) A person who attaches an accessory plate for a tow truck to an unregistered vehicle to be towed by the tow truck must attach it to the rearmost end of the vehicle, as towed, in a way that is as nearly as practicable in the same way a number plate would be required to be attached to that end of the vehicle were it a registered vehicle.

Maximum penalty for subsection (5)—12 penalty units.

Division 5 Registration labels

32 Chief executive to issue registration labels

- (1) When a vehicle is registered, the chief executive must issue a label for the vehicle to its registered operator.
- (2) The label must be in the approved form and include the following particulars for the vehicle—
 - (a) its registration number;
 - (b) its make;
 - (c) its model or body type, according to which is the more descriptive;
 - (d) its VIN or, if the vehicle does not have a VIN, the vehicle's chassis number or engine number;
 - (e) the expiry day of its registration;
 - (f) if the vehicle is a conditionally registered vehicle, the codes for the conditions of use applying to the vehicle that are stated on the registration certificate for the vehicle;
 - (g) its GCM and GVM;
 - (h) the vehicle charging category code;
 - (i) if the vehicle is a motorbike, other than a motorbike that is conditionally registered, whether the vehicle is a learner approved motorbike.

33 Position for attaching registration label

- (1) The registered operator of a vehicle must attach the vehicle's registration label to the vehicle—
 - (a) so as to be clearly visible from outside the vehicle; and
 - (b) in a way complying with subsections (2) to (6).

Maximum penalty—6 penalty units.

- (2) If the vehicle is a motorbike, the label must be placed in a holder attached to the motorbike on the left-hand side or rear of the motorbike.
- (3) If the vehicle is a trailer that is a category 1 vehicle, the label must be placed to the left-hand side or rear of the trailer.
- (4) If the vehicle is a trailer that is a category 2 vehicle, the label must be placed on or adjacent to the trailer's number plate.
- (5) If the vehicle is other than a vehicle mentioned in subsections (2) to (4) and has a windscreen, the label must be placed—
 - (a) to the lower left-hand corner of the vehicle's windscreen; or
 - (b) to a fixed or pivoted window on the left-hand side of the vehicle.
- (6) If the vehicle is other than a vehicle mentioned in subsections (2) to (4) and does not have a windscreen, the label must be attached, whether or not by a holder, to the left-hand side of the vehicle as near as practicable to the position mentioned in subsection (5)(a).
- (7) The registered operator must take the registration label off the vehicle and destroy it immediately on the sooner of the following—
 - (a) the day another registration label issued for the vehicle is attached to the vehicle;
 - (b) 21 days after the expiry day of the registration to which the registration label relates.

Maximum penalty—6 penalty units.

[s 34]

34 Time for attaching registration label

- (1) The registered operator of a vehicle must attach the vehicle's registration label to the vehicle—
 - (a) for a label issued on initial registration—within 21 days after the application for registration is made; or
 - (b) for a label issued on an application for renewal of registration—
 - (i) if the label is issued before the registration expires—within 21 days after the day on which the registration would have expired if it had not been renewed; or
 - (ii) if the label is issued after the registration expires—within 21 days after the application is made; or
 - (c) for a replacement label—
 - (i) if the label is issued on an application for a replacement label—within 21 days after the application is made; or
 - (ii) if the label is issued as an updated registration label—within 21 days after the chief executive is notified of the matters requiring the issue of an updated registration label.

Maximum penalty—6 penalty units.

- (2) A person does not contravene subsection (1) if it is not reasonably practicable to attach the label within the required time because of a delay by the chief executive in issuing the label.

Part 4 Renewal of registration

36 Registration renewal notice

- (1) A registration renewal notice (a *renewal notice*) for a registered vehicle is a notice sent by the chief executive—
 - (a) addressed to—
 - (i) if the vehicle’s registered operator has given the chief executive a written direction to address the notice to another person—the person; or
 - (ii) otherwise—the vehicle’s registered operator; and
 - (b) stating that, if the vehicle’s registration is not renewed on or before a stated day, it expires.
- (2) However, if the chief executive does not send, or the registered operator does not receive, a renewal notice, the non-receipt of the notice does not affect—
 - (a) the expiry of the vehicle’s registration; or
 - (b) the registered operator’s obligation to renew the vehicle’s registration before it expires, if the registered operator intends to use the vehicle on a road after the existing registration expires.

37 Renewal of registration

- (1) A vehicle’s registration may be renewed by presenting the renewal notice, or a written request to renew the vehicle’s registration, to the chief executive together with the following—
 - (a) any relevant registration fee;
 - (b) any registration administration fee for a conditionally registered vehicle;
 - (c) if the vehicle is a category 1 vehicle, the category 1 vehicle traffic improvement fee;

[s 37]

- (d) if the vehicle is a category 2 vehicle, other than a trailer, the category 2 registration administration fee;
 - (e) an insurance certificate under the *Motor Accident Insurance Act 1994* for the vehicle for the proposed term of registration or the insurance premium payable under that Act for the certificate;
 - (f) if the vehicle is a COI vehicle under the Vehicle Standards and Safety Regulation, a current certificate of inspection under that regulation for the vehicle, but only if its owner is required under that regulation to possess a current certificate of inspection for the vehicle.
- (2) The person renewing the registration must nominate the registration term for the vehicle.
 - (3) The registration term must be a term available under section 19 or 37B or permitted under section 20.
 - (4) The registration of a vehicle may be renewed—
 - (a) if the vehicle is registered for a term permitted under section 20—not more than 1 year after its registration expires; or
 - (b) otherwise—not more than 2 months after its registration expires.
 - (5) Despite subsection (4), the chief executive may accept an application for renewal of registration at any time if the chief executive considers it reasonable in the circumstances to do so.
 - (6) The expiry day of a renewed term of registration for a vehicle must be worked out as if the renewal had commenced—
 - (a) if the vehicle is registered for a term permitted under section 20—on the first day of the nominated term; or
 - (b) otherwise—on the day after the day recorded in the register as the expiry day of the registration being renewed.
 - (7) Subsections (4) to (6) do not have the effect of retrospectively registering a vehicle.

-
- (8) If the period by which a vehicle's registration may be renewed has ended but the registration has not been renewed, the chief executive may, by written notice given to the person who was recorded as the vehicle's registered operator before the registration expired, require the person to return the vehicle's number plates to the chief executive within 14 days after the notice is given.
- (9) A person of whom a requirement is made under subsection (8) must not contravene the requirement, unless the person has a reasonable excuse.
- Maximum penalty—20 penalty units.
- (10) Despite anything in subsections (1) to (9), a person may renew a vehicle's registration using any of the ways stated in the renewal notice for the particular renewal.
- (11) Despite anything in subsections (1) to (10), the chief executive may refuse an application for the renewal of the registration of a vehicle under the same circumstances, and in the same way, that the chief executive may refuse an application for the registration of a vehicle under section 14.

37A When surcharge is payable for renewal

- (1) This section applies if—
- (a) an applicant for renewal of registration for a vehicle is not required to pay a CTP insurance premium to the chief executive under section 37(1)(e) in relation to the renewal; and
 - (b) the applicant underpays the registration-related amount for the renewal by more than \$1.
- (2) This section also applies if—
- (a) an applicant for renewal of registration for a vehicle is required to pay a CTP insurance premium to the chief executive under section 37(1)(e) in relation to the renewal; and

[s 37B]

- (b) the amount paid by the applicant for the purpose of the registration-related amount for the renewal is more than \$1 below what the registration-related amount would be if—
 - (i) the relevant registration fee payable under section 37(1)(a) for the renewal were for 1 year's registration; and
 - (ii) the CTP insurance premium payable under section 37(1)(e) in relation to the renewal were the lowest premium set by any CTP insurer for insurance covering 1 year's registration.
- (3) The applicant under subsection (1) or (2) must pay the surcharge provided for in schedule 3.

37B Registration term if overpayment or underpayment of registration-related amount and any surcharge

- (1) This section applies if an applicant for renewal of registration for a vehicle—
 - (a) does not present an insurance certificate under the *Motor Accident Insurance Act 1994* for the vehicle for the proposed term of registration to the chief executive under section 37(1)(e); and
 - (b) overpays or underpays the total of the registration-related amount for the renewal and any surcharge payable for the renewal.
- (2) Despite section 19, the registration may be renewed for a term that is in proportion to the amount paid after deducting—
 - (a) any surcharge payable for the renewal; and
 - (b) any administrative fee for late payment payable for the renewal.
- (3) However, the registration must not be renewed under subsection (2) if the amount paid is more than \$1 below what the total of the registration-related amount for the renewal and any surcharge payable for the renewal would be if any CTP insurance premium, payable under section 37(1)(e) in relation

to the renewal, for the minimum available registration term for the vehicle, were the lowest premium set by any CTP insurer.

- (4) Also, if the amount paid is more than the registration-related amount for the renewal that would be payable if the registration were to be renewed for 14 months—
 - (a) the vehicle's registration may only be renewed for 1 year; and
 - (b) the difference between the amount paid and the registration-related amount for the 1 year renewal must be refunded.
- (5) If the term of registration would, other than for this subsection, not be a whole number of days—
 - (a) the term must be rounded down to the nearest whole day; and
 - (b) the difference between the amount paid and the total of the registration-related amount for the renewal and any surcharge payable for the renewal must be credited to the applicant.
- (6) If subsection (3) applies, the chief executive must refund the amount paid to the applicant.
- (7) The chief executive must give the applicant a written notice stating—
 - (a) the term of registration for the vehicle; or
 - (b) that the amount paid is being refunded because it is below the minimum required to enable renewal of registration.

37C Administrative fee for late payment if cheque dishonoured

- (1) This section applies if—
 - (a) payment for part or all of the amount payable for renewal of registration is made, before the expiry day of the registration, by cheque or other method of payment; and

[s 38]

- (b) the cheque or payment is not honoured on presentation or is later dishonoured; and
 - (c) payment for part or all of the amount payable for the renewal is made after the expiry day of the registration.
- (2) In applying the administrative fee for late payment, the purported payment made before the expiry day must be disregarded.

38 Issue of receipt and updating of records

- (1) The renewal of the registration of a vehicle is effective—
- (a) if the renewal involves the issue of the chief executive's receipt for payment before the expiry of the term of registration being renewed—immediately after the expiry of that term; or
 - (b) if the renewal does not involve the issue of the chief executive's receipt for payment but involves transactions that are completed before the expiry of the term of registration being renewed, including on the day of the expiry—immediately after the expiry of that term; or
 - (c) if the renewal involves the issue of the chief executive's receipt for payment after the expiry of the term of registration being renewed—on the issue of the chief executive's receipt for payment; or
 - (d) if the renewal does not involve the issue of the chief executive's receipt for payment but involves transactions that are completed after the expiry of the term of registration being renewed—on the completion of the transactions.
- (3) If the chief executive renews the registration of a vehicle, the chief executive must—
- (a) update the records for the vehicle in the register; and
 - (b) issue to the registered operator—
 - (i) an updated registration certificate; and
 - (ii) a registration label.

-
- (4) Subsection (3)(b)(ii) applies only if the vehicle is a vehicle for which a registration label is required to be issued when the vehicle is registered.

Part 5 Transfer of registration

39 Transfer of registration

- (1) A person who buys or otherwise acquires, a registered vehicle must apply to the chief executive for transfer of the vehicle's registration within 14 days after acquiring it.

Maximum penalty—16 penalty units.

- (2) The application must be in the approved form and accompanied by the following, to the extent they are applicable—

- (a) the relevant fee;
- (b) any other amounts due, including fees payable for the renewal of the vehicle's registration;
- (c) the duty payable under the *Duties Act 2001*;
- (d) a gas certificate for each gas system in the vehicle;
- (e) if the purchase or other acquisition of the registered vehicle is a disposal for which, under the Vehicle Standards and Safety Regulation, a current inspection certificate is required, a current inspection certificate under that regulation for the vehicle.

- (3) However, subsection (2)(a) to (c) does not apply to a transfer lodged under subsection (7).

- (4) A dealer who acquires a registered vehicle must notify the chief executive of the acquisition in the approved form within 14 days after the acquisition.

Maximum penalty—16 penalty units.

[s 39]

- (5) All amounts payable under subsection (2)(a) and (c) are payable by the person who acquires a vehicle from the day of transfer appearing in the application form.
- (6) If a person who acquires a registered vehicle can not find out the full name and address of the person who sold or disposed of the vehicle or obtain the signature of the person who sold or disposed of the vehicle on an approved form, the person acquiring the vehicle must give a written statement to that effect to the chief executive.
- (7) If a person (the *disposer*) disposes of a registered vehicle to someone else (the *acquirer*) and reasonably believes the acquirer has not applied for transfer of the vehicle's registration within 14 days after acquiring it, the disposer may—
 - (a) apply in the approved form for transfer of the vehicle's registration to the acquirer; or
 - (b) give notice (a *disposal notice*) to the chief executive, in the approved form, of the disposer's disposal to the acquirer.
- (8) The chief executive, on receipt of an application under subsection (1) or (7)(a), or a notification under subsection (4), or on being satisfied as to the correctness of the information contained in a statement received under subsection (6), may—
 - (a) record in the register the day of the transfer appearing in the approved form; and
 - (b) substitute the name and address of the person acquiring the vehicle for those of the registered operator recorded in the register; and
 - (c) issue an updated registration certificate.
- (9) On receipt of a disposal notice under subsection (7)(b), the chief executive may—
 - (a) record in the register the day of disposal stated in the notice; and

-
- (b) substitute the name and address of the acquirer of the vehicle for those of the registered operator recorded in the register; and
 - (c) by written notice given to the acquirer, require the acquirer to apply for transfer of the vehicle's registration within 14 days after the notice is given.
- (10) The acquirer must not contravene the requirement mentioned in subsection (9)(c) unless the acquirer has a reasonable excuse.

Maximum penalty—16 penalty units.

- (11) If the chief executive acts under subsection (9), the person in whose name the vehicle is registered or recorded in the register under a disposal notice is taken to be the vehicle's registered operator for this regulation until the chief executive receives notice of the transfer or disposal of a vehicle.

40 Failure by dealer to apply for transfer of registration

- (1) This section applies if—
- (a) a person (the *buyer*) buys or otherwise acquires a registered vehicle from a dealer; and
 - (b) the dealer accepts from the buyer an amount mentioned in section 39(2)(a), (b) or (c).
- (2) The dealer must, within 14 days after the buyer's acquisition of the vehicle, apply to the chief executive on the buyer's behalf for transfer of the vehicle's registration.

Maximum penalty—16 penalty units.

- (3) The buyer does not contravene section 39(1) if an application is not made to the chief executive for transfer of the vehicle's registration within 14 days after the buyer's acquisition of the vehicle.

[s 41]

41 Transfer of registration under legal process

- (1) A person who obtains a registered vehicle under a legal process must notify the chief executive in the approved form within 14 days after obtaining the vehicle.

Maximum penalty—16 penalty units.

- (2) A person who repossesses a registered vehicle that is not redeemed within 28 days after the repossession must, within a further 7 days, notify the chief executive in the approved form.

Maximum penalty—16 penalty units.

- (3) A person mentioned in subsection (1) or (2) (the *new owner*) who can not obtain the signature of the vehicle's registered operator on the approved form, must give a written statement to that effect to the chief executive.

- (4) Subsection (5) applies if the chief executive is satisfied—

- (a) the information contained in a statement received under subsection (3) is correct; and
- (b) the new owner has a lawful entitlement to the vehicle.

- (5) The chief executive may—

- (a) record the day of the transfer appearing in the approved form in the register; and
- (b) substitute the new owner's name and address for those of the registered operator recorded in the register; and
- (c) give the new registered operator an updated registration certificate.

- (6) A notification in the approved form under subsection (1) or (2) must be accompanied by the amounts, and by the documents, that would be required under section 39(2) were the notification an application for a transfer of the vehicle's registration.

42 Refusing to register transfer of registration

- (1) The chief executive may refuse to register a transfer of a vehicle's registration if—
 - (a) the vehicle is a conditionally registered vehicle and a condition in the safe movement guideline is that the registration is not transferable; or
 - (b) the chief executive reasonably believes there is uncertainty about the ownership, possession or control of the vehicle or that the description of the vehicle as recorded in the register may be inaccurate; or
 - (c) were the vehicle to be the subject of an application for registration, the chief executive would refuse the application.
- (2) If an order of an Australian court prohibits the transfer of a vehicle's registration and the chief executive has notice of the order, the chief executive must not register a transfer of the registration.
- (3) Subsections (1) and (2) do not limit the chief executive's power to refuse to register the transfer of a vehicle's registration.

Part 6 Expiry and cancellation of registration

Division 1 Expiry of registration

43 Expiry of registration

A vehicle's registration expires at the end of the day recorded in the register as the expiry day of the registration unless the registration is sooner cancelled or renewed under this regulation.

[s 44]

44 Return of registration plates when registration expires

- (1) The chief executive may by written notice given to the person who was the registered operator of a vehicle whose registration has expired, require the person to return the vehicle's number plates to the chief executive within 14 days of the date of the notice (the *return period*).
- (2) The person must, within the return period—
 - (a) return the vehicle's number plates to the chief executive; or
 - (b) if the plates have been lost, stolen or destroyed, notify the chief executive in writing of the details of the loss, theft or destruction.

Maximum penalty—20 penalty units.

Division 2 Cancellation of registration

45 Cancellation of registration at registered operator's request

- (1) The registered operator of a vehicle may apply to the chief executive to cancel the vehicle's registration if—
 - (a) the registered operator of the vehicle is a dealer, and the vehicle is for sale; or
 - (b) the vehicle—
 - (i) has been stolen; or
 - (ii) has been taken out of the State; or
 - (iii) has ceased to be used on roads; or
 - (iv) is a total loss.
- (1A) The application must be made in the approved form.
- (1B) If cancellation is applied for under subsection (1)(b)(iv), the approved form must include a statement by or for the applicant that the vehicle has not been used on a road since it became a total loss.

-
- (2) Also, a person acting under the authority of a court to sell a vehicle may apply to the chief executive to cancel the vehicle's registration.
 - (3) If the application of a person (the *applicant*) to cancel a vehicle's registration is made by another person on behalf of the applicant, the other person must give the chief executive written evidence of the other person's appointment, as the registered operator's agent, with the application.
 - (4) If a person acting under the authority of a court to sell a vehicle applies to the chief executive to cancel the vehicle's registration, the person must give the chief executive, with the application, written evidence of the person's authority to sell the vehicle.
 - (5) A person applying under subsection (1) or (2) must include with the application—
 - (a) if the registration label or a number plate has been lost, stolen or destroyed—each item that has not been lost, stolen or destroyed, and a statement advising of the loss, theft or destruction of the other item or items; or
 - (b) if paragraph (a) does not apply—the registration label and each number plate for the vehicle.
 - (5A) Also, if the vehicle is a total loss, the person must include with the application the notifiable information for the vehicle the person would have been required to give the chief executive under section 55J.
 - (6) The chief executive must cancel the vehicle's registration unless—
 - (a) the applicant has not complied with subsection (3), (4), (5) or (5A); or
 - (b) the chief executive is already taking action to cancel the registration because of a ground existing under section 47 or 48.

[s 45A]

45A Cancellation if registration in other State

The chief executive may cancel a vehicle's registration other than on a person's application if the chief executive knows that the vehicle has been registered in another State under a corresponding law to this regulation.

46 Partial refund of registration fee

- (1) This section applies if a vehicle's registration is cancelled under section 45 or 45A.
- (2) The chief executive must make a partial refund of the registration fee paid for the vehicle to the person who was the registered operator immediately before the cancellation.
- (3) The refund is worked out using the following formula—

$$\text{refund} = \frac{\text{number of days}}{365} \times \text{annual registration fee}$$

where—

number of days is the number of unexpired whole days of the registration term for which the fee was paid, from the day on which the chief executive approves the application to cancel the registration.

- (4) However, the chief executive may deduct from the refund—
 - (a) an amount decided by the chief executive to cover reasonable administrative costs; and
 - (b) any unpaid fees payable under a transport Act for the vehicle.

47 Cancellation for noncompliance with defect notice

- (1) A ground exists to cancel the registration of a registered vehicle if—
 - (a) a defect notice is issued under the Vehicle Standards and Safety Regulation for the vehicle; and

-
- (b) the vehicle's registered operator contravenes the requirements of the defect notice; and
 - (c) the chief executive gives the registered operator a written notice (the **warning notice**) stating that a ground will exist to cancel the vehicle's registration under section 19 of the Act at the end of 14 days after the date of the warning notice if the registered operator does not, within that time—
 - (i) comply with the defect notice; or
 - (ii) ask the chief executive to cancel the vehicle's registration; and
 - (d) the chief executive is satisfied that the registered operator has not complied with all the requirements of the defect notice within the 14 days mentioned in paragraph (c); and
 - (e) the registered operator has not asked the chief executive to cancel the vehicle's registration.
- (2) If the chief executive decides to cancel the registration under section 19(2)(c) of the Act, the chief executive must include in the written notice given under section 19(3) of the Act a requirement that the person (the **relevant person**) to whom the notice is directed must return the vehicle's registration label and number plates to the chief executive within 14 days after the giving of the notice (the **return period**).
- (3) The relevant person must return the vehicle's registration label and number plates to the chief executive within the return period.
- Maximum penalty—20 penalty units.
- (4) However, if the registration label or a number plate has been lost, stolen or destroyed, the relevant person does not contravene subsection (3) in relation to the registration label or number plate if the relevant person, within the return period, notifies the chief executive in writing of the details of the loss, theft or destruction.

[s 48]

48 Cancellation of registration of vehicle or dealer plate

- (1) This section applies if—
 - (a) a vehicle does not conform with the requirements applying to the vehicle under a vehicle law about the construction, equipment and performance of motor vehicles; or
 - (b) the registered operator of a vehicle does not comply with a notice given under section 39(9)(c); or
 - (c) the registration or renewal of registration of a vehicle or dealer plate is paid for by a cheque, or by another method of payment, that is not honoured on presentation, and the chief executive has not yet received full payment for the registration or renewal; or
 - (d) less than the correct amount is paid in relation to the payment for registration, or renewal of registration, of a vehicle or dealer plate, and the chief executive has not yet received the unpaid amount; or
 - (e) a vehicle is recorded in the register as a written-off vehicle; or
 - (f) the application for the registration of a vehicle or dealer plate was not accompanied by a document required under section 11(1) in relation to a vehicle or section 52(3) in relation to a dealer plate.
- (2) If this section applies in relation to a vehicle, a ground exists to cancel the registration of the vehicle.
- (3) If the chief executive decides to cancel the vehicle's registration under section 19(2)(c) of the Act, the chief executive must include in the written notice given under section 19(3) of the Act a requirement that the person (the ***relevant person***) to whom the notice is directed must return the vehicle's registration label and number plates to the chief executive within 14 days after the giving of the notice (the ***return period***).

-
- (4) The relevant person must return the vehicle's registration label and number plates to the chief executive within the return period.

Maximum penalty—20 penalty units.

- (5) However, if the registration label or a number plate has been lost, stolen or destroyed, the relevant person does not contravene subsection (4) in relation to the registration label or number plate if the relevant person, within the return period, notifies the chief executive in writing of the details of the loss, theft or destruction.

- (6) If this section applies in relation to a dealer plate, a ground exists to cancel the registration of the dealer plate.

- (7) If the chief executive decides to cancel the registration of the dealer plate under section 19(2)(c) of the Act, the chief executive must include in the written notice given under section 19(3) of the Act a requirement that the person (the *dealer plate holder*) to whom the notice is directed must return the dealer plate to the chief executive within 14 days after the giving of the notice (the *dealer plate return period*).

- (8) The dealer plate holder must return the dealer plate to the chief executive within the dealer plate return period.

Maximum penalty—30 penalty units.

- (9) However, if the dealer plate has been lost, stolen or destroyed, the dealer plate holder does not contravene subsection (8) if the dealer plate holder, within the dealer plate return period, notifies the chief executive in writing of the details of the loss, theft or destruction.

- (10) Nothing in this section stops the chief executive from recovering from the relevant person or dealer plate holder an amount, worked out on a proportional basis, of any amount for registration referable to the period ending on the cancellation.

- (11) Section 56 of the Act does not apply to a registration, or renewal of registration, of a vehicle or dealer plate.

[s 49]

49 Recording cancellation of registration in register

- (1) If the chief executive cancels a vehicle's registration, the chief executive must record the cancellation in the register.
- (2) If the registered operator applied for the cancellation under section 45(1)(a) or (b)(iii), the cancellation is effective on the day of receipt of the application conforming with that section.
- (3) If the registered operator applied for the cancellation under section 45(1)(b)(i), the cancellation is effective on the day after the vehicle is reported as stolen to the police service.
- (3A) If the registered operator applied for the cancellation under section 45(1)(b)(iv), the cancellation is effective on the day after the day the vehicle stopped being used on roads as a result of it having become a total loss.
- (4) If the registered operator applied for cancellation under section 45(1)(b)(ii), the cancellation is effective on the day of receipt of the application conforming with that section.
- (5) However, if on an application under subsection 45(1)(b)(ii) the chief executive is satisfied the vehicle has been registered in another State under a corresponding law to this regulation, the cancellation is taken to be effective on the day immediately after the day the vehicle was registered in the other State.
- (6) If the chief executive cancels a vehicle's registration under section 45A, the cancellation is taken to be effective on the day immediately after the day the vehicle was registered in the other State.
- (7) If none of subsections (2) to (6) applies, the cancellation is effective on the day the chief executive records the cancellation in the register.

Part 7 **When registration unnecessary**

Division 1 **Unregistered vehicle permits**

50 **Unregistered vehicle permits**

- (1) The chief executive may authorise the use of an unregistered vehicle on a road by issuing an unregistered vehicle permit for the vehicle.
- (2) An applicant for the permit must apply to the chief executive in the approved form, accompanied by—
 - (a) the relevant fee; and
 - (b) an insurance certificate under the *Motor Accident Insurance Act 1994* for the vehicle for the proposed term of the permit.
- (3) The chief executive may issue the permit for the term, which must not be longer than 7 days, and on the reasonable conditions, stated in it.
- (4) If the permit is issued on conditions, it is void if the conditions are contravened.
- (5) A person to whom an unregistered vehicle permit is issued must ensure that, whenever the vehicle is being used under the permit on a road—
 - (a) if the vehicle is a motorbike or a vehicle that may be conditionally registered—the driver carries the permit; or
 - (b) if the vehicle is a trailer—the permit is carried in the vehicle towing the trailer; or
 - (c) otherwise—the permit is attached to the vehicle in the way required under section 33 as if it were a registration label.

Maximum penalty—12 penalty units.

[s 51]

- (6) The chief executive may not issue an unregistered vehicle permit for a vehicle that—
 - (a) does not conform with a vehicle law; or
 - (b) is recorded in the register, or in a register kept under a corresponding law to this regulation, as a written-off vehicle.

Division 2 Dealer plates

51 Designation of dealer plates

The chief executive may designate a series of number plates as dealer plates.

52 Registration of dealer plate

- (1) An unregistered vehicle may be used on a road if—
 - (a) a dealer plate is attached to the vehicle; and
 - (b) the registration of the dealer plate is current.
- (2) The chief executive must not register a dealer plate unless the chief executive is satisfied that the person in whose name the dealer plate is to be registered is a person who requires the plate for the conduct of the person's business.
- (3) An applicant for a dealer plate must apply to the chief executive in the approved form, which must be accompanied by—
 - (a) the relevant fee; and
 - (b) an insurance certificate under the *Motor Accident Insurance Act 1994* for the proposed registration term or the insurance premium payable under that Act for the certificate.
- (4) On registering the dealer plate, the chief executive must—
 - (a) assign a registration number; and

-
- (b) record in the register the following particulars—
 - (i) the name, address and place of business of the person to whom the plate has been issued;
 - (ii) commencement and expiry days for the registration of the dealer plate; and
 - (c) give the applicant—
 - (i) a registration certificate; and
 - (ii) the dealer plate; and
 - (iii) a registration label for the dealer plate.
 - (5) The registration of a dealer plate is renewable, but is not transferable.
 - (6) In this section—
 - unregistered vehicle* does not include a vehicle that—
 - (a) is not capable of being registered under this regulation;
or
 - (b) is only capable of being conditionally registered.

53 Attaching dealer plate

- (1) The person in whose name a dealer plate is registered must ensure that when an unregistered vehicle is used under the authority of the dealer plate on a road—
 - (a) the registration label for the dealer plate is attached to the dealer plate; and
 - (b) the dealer plate is attached to the vehicle in the way required under subsection (2).

Maximum penalty—12 penalty units.

- (2) The plate must be attached to the vehicle in the way required if the dealer plate were a number plate issued for the vehicle.
- (3) Subsection (1)(a) does not apply if—

[s 54]

- (a) fewer than 14 days have elapsed since the dealer plate was registered, or the dealer plate's registration was renewed, in the person's name; and
- (b) the person has not yet received the registration label from the chief executive.

54 Use of dealer plates

- (1) A person must not use, or permit to be used, on a road, a vehicle with a dealer plate attached to it unless the vehicle—
 - (a) is being demonstrated for its sale; or
 - (b) is being delivered to a purchaser after sale; or
 - (c) is travelling to or from a workshop or another facility for—
 - (i) painting, repairs or motor body construction work; or
 - (ii) the fitting of optional equipment before delivery to a purchaser; or
 - (d) is being tested after having been painted or repaired, or after having been the subject of motor body construction work; or
 - (e) is being used for demonstration purposes for the conduct of an art union under the *Charitable and Non-Profit Gaming Act 1999*; or
 - (f) is being used for a purpose approved by the chief executive in a written notice given to the person in whose name the dealer plate is registered; or
 - (g) is being driven or towed to an AIS under the Vehicle Standards and Safety Regulation for inspection for obtaining an inspection certificate under that regulation; or
 - (h) is recorded in the register as a repairable write-off and is being driven or towed to a written-off vehicle inspection site for obtaining a written-off vehicle inspection report; or

-
- (i) is being driven or towed to a place as required by the chief executive; or
 - (j) is being driven or towed to an office of the chief executive to be registered; or
 - (k) is being driven or towed from the manufacturer or a distributor of the vehicle to a dealer; or
 - (l) is being driven or towed between a dealer's premises where vehicles are sold or displayed for sale and other premises, of the same or a different dealer, where vehicles are sold or displayed for sale, whether or not a sale has taken place.

Maximum penalty—16 penalty units.

- (2) A person must not use, or permit to be used, on a road, a vehicle with a dealer plate, other than a dealer (trailer trade) plate, attached to it if the vehicle is carrying a load or towing a vehicle carrying a load, unless the vehicle with the dealer plate attached—
 - (a) is a boat trailer carrying a boat; or
 - (b) is towing a motor vehicle travelling on its rear wheels only, with its front portion mounted on the towing vehicle; or
 - (c) is carrying the load only to demonstrate the vehicle for its sale, and not for hire or reward.

Maximum penalty—40 penalty units.

- (3) A person must not use, or permit to be used, on a road, a vehicle with a dealer (trailer trade) plate attached to it unless the vehicle is—
 - (a) a trailer not carrying a load; or
 - (b) is a boat trailer, carrying 1 or more boat trailers, being towed from the manufacturer or a distributor of all the trailers to a dealer; or
 - (c) a boat trailer carrying a boat; or

[s 55]

- (d) a trailer carrying a load only to demonstrate the trailer for its sale, and not for hire or reward.

Maximum penalty—40 penalty units.

- (4) A person (the *vehicle user*) must not use, on a road, a vehicle with a dealer plate attached to it unless the person in whose name the dealer plate is registered has authorised the vehicle user to use the dealer plate.

Maximum penalty—16 penalty units.

- (5) In this section—

dealer (trailer trade) plate means a dealer plate issued under this division authorising the use of an unregistered trailer on a road.

55 Cancellation of dealer plates

- (1) The chief executive may cancel the registration of a dealer plate, and record the cancellation in the register, if the person in whose name the plate is registered—
- (a) applies in writing to the chief executive for the cancellation; and
- (b) unless the person has notified the chief executive in writing of details of the loss, theft or destruction of the dealer plate—returns the dealer plate to the chief executive.
- (2) Subsection (3) applies if either of the following events (the *relevant event*) happens in relation to a person in whose name a dealer plate is registered—
- (a) the person stops carrying on the business for which the plate was registered;
- (b) there is a material change in the nature of the person's business from that stated in the person's application for the registration of the plate.
- (3) The person must, within 14 days after the relevant event happens—

-
- (a) notify the chief executive in writing about the relevant event; and
 - (b) return the dealer plate to the chief executive.

Maximum penalty—30 penalty units.

- (4) On receiving a notification under subsection (3), the chief executive must cancel the registration of the dealer plate and record in the register the cancellation of the registration.
- (5) A ground exists to cancel the registration of a dealer plate if a person required to comply with subsection (3) does not notify the chief executive under the subsection.
- (6) If, the chief executive decides to cancel the registration of a dealer plate under section 19(2)(c) of the Act, the chief executive must include in the written notice given under section 19(3) of the Act a requirement that the person (the *relevant person*) to whom the notice is directed must, unless the relevant person has already done so, return the dealer plate to the chief executive within 14 days after the giving of the notice.
- (7) The relevant person must comply with the requirement under subsection (6).

Maximum penalty—30 penalty units.

- (8) If a dealer plate required to be returned under subsection (3)(b) or (7) (the *relevant provision*) has been lost, stolen or destroyed, the person required to return the plate does not contravene the relevant provision if the person, in the period within which the dealer plate is required to be returned, notifies the chief executive in writing of the details of the loss, theft or destruction.
- (9) The cancellation of the registration of a dealer plate is effective—
 - (a) for a cancellation under subsection (1)—immediately the person has complied with the subsection; or
 - (b) otherwise—on the day the chief executive records the cancellation in the register.

[s 55A]

Part 7A Written-off vehicles

Division 1 Objects of part 7A

55A Objects

The objects of this part include—

- (a) to provide for the collection of information about written-off vehicles; and
- (b) to provide for the inspection of written-off vehicles that are repairable write-offs.

Division 2 Notifying of written-off vehicle information

55B General obligations of notifiers

- (1) The chief executive may require a notifier required to give notifiable information for a written-off vehicle under this regulation to give to the chief executive information in the approved form.
- (2) The information the chief executive may require under subsection (1) must be information the chief executive reasonably considers is required to maintain the integrity of information about written-off vehicles kept by the chief executive in the register.
- (3) The notifier must comply with a requirement given under this section.

Maximum penalty for subsection (3)—20 penalty units.

55C Auditing of notifiers

- (1) The chief executive must conduct audits of notifiers' operations as givers of notifiable information about written-off vehicles under this regulation.
- (2) A notifier must allow the notifier's operations as a giver of notifiable information to be audited by the chief executive.

Maximum penalty—20 penalty units.

- (3) If the report of an audit under this section identifies noncompliance with this regulation, the chief executive may, by written notice given to the notifier, require the notifier to give the chief executive, within 14 days after the date of the notice, a notice signed by the notifier stating the action the notifier has taken to do either or both of the following, as directed in the chief executive's notice—
 - (a) rectify the non-compliance;
 - (b) ensure that the non-compliance does not continue or happen again.
- (4) The notifier must comply with the requirement, unless the notifier has a reasonable excuse.

Maximum penalty—20 penalty units.

- (5) In a proceeding against the notifier for an offence against this regulation, other than for an offence against subsection (4), neither the notice given by the notifier, nor the fact that the notifier gave the notice, can be used in evidence against the notifier.
- (6) If an audit report identifies material non-compliance with this regulation, the notifier must pay the cost of the audit and of compiling the audit report, but is not otherwise required to pay the cost.

55D Obligation of notifiers to give notifiable information

- (1) A notifier must give notifiable information for a vehicle to the chief executive—
 - (a) in the approved form; or

[s 55E]

- (b) if the notifier obtains the chief executive's approval to give the notifiable information in an electronic form—in the electronic form.
- (2) A notifier may change details of the notifiable information for a vehicle given to the chief executive only if—
 - (a) the vehicle has not been repaired; and
 - (b) the vehicle has not left the notifier's possession since the notifier gave the information to the chief executive.
- (3) A notifier must not knowingly or recklessly give notifiable information for a vehicle to the chief executive that is false or misleading in a material particular.

Maximum penalty for subsection (3)—80 penalty units.

55E Obligation of insurer to report written-off vehicle

- (1) This section applies if an insurer, in the course of the business carried on by the insurer in the State, and whether or not on the advice of a loss adjuster—
 - (a) assesses as a total loss a notifiable vehicle registered under this regulation; or
 - (b) assesses as a total loss a notifiable vehicle that is anywhere in Australia, but is not registered under this regulation or a corresponding law to this regulation.
- (2) The insurer must give the chief executive the notifiable information for the vehicle before the first of the following happens—
 - (a) 7 days elapse after the insurer makes a final decision for a claim in relation to the vehicle;
 - (b) the insurer—
 - (i) disposes of the vehicle; or
 - (ii) disposes of any part of the vehicle that has a chassis number or VIN; or
 - (iii) sells the vehicle; or

- (iv) sells any part of the vehicle that has a chassis number or VIN.

Maximum penalty for subsection (2)—50 penalty units.

55F Obligation of self-insurer to report written-off vehicle

- (1) This section applies if a self-insurer—
 - (a) assesses as a total loss a notifiable vehicle registered under this regulation in the name of the self-insurer; or
 - (b) assesses as a total loss a notifiable vehicle that is anywhere in Australia and is owned by the self-insurer, but is not registered under this regulation or a corresponding law to this regulation.
- (2) The self-insurer must give the chief executive the notifiable information for the vehicle before the first of the following happens—
 - (a) 7 days elapse after making the assessment;
 - (b) the self-insurer—
 - (i) disposes of the vehicle; or
 - (ii) disposes of any part of the vehicle that has a chassis number or VIN; or
 - (iii) sells the vehicle; or
 - (iv) sells any part of the vehicle that has a chassis number or VIN.

Maximum penalty for subsection (2)—50 penalty units.

55G Obligation of loss adjuster to report written-off vehicle

- (1) This section applies if a loss adjuster, acting in the course of the business carried on by the loss adjuster, but acting other than to advise an insurer, auctioneer or dealer—
 - (a) assesses as a total loss a notifiable vehicle registered under this regulation; or

[s 55H]

- (b) assesses as a total loss a notifiable vehicle that is in the State, but is not registered under this regulation or a corresponding law to this regulation.
- (2) The loss adjuster must give the chief executive the notifiable information for the vehicle within 7 days after finalising the loss adjuster's assessment of the vehicle.

Maximum penalty for subsection (2)—50 penalty units.

55H Obligation of dealer or auctioneer to report written-off vehicle

- (1) This section applies if a person who is a dealer or an auctioneer, in the course of the business carried on by the person, has in the person's possession—
 - (a) a notifiable vehicle, registered under this regulation, that is a total loss; or
 - (b) a notifiable vehicle, not registered under this regulation or a corresponding law to this regulation, that is a total loss.
- (2) The person must give the chief executive the notifiable information for the vehicle before the first of the following happens—
 - (a) 7 days elapse after the person takes possession of the vehicle;
 - (b) the auctioneer or dealer—
 - (i) disposes of the vehicle; or
 - (ii) disposes of any part of the vehicle that has a chassis number or VIN; or
 - (iii) sells the vehicle; or
 - (iv) sells any part of the vehicle that has a chassis number or VIN.

Maximum penalty—50 penalty units.

-
- (3) The person is not required to act under subsection (2) if someone else has already given the notifiable information for the vehicle to the chief executive.
 - (4) In this section—
possession includes custody or control.

55I Obligation of auto parts dismantler to report written-off vehicle

- (1) This section applies if a person who is an auto parts dismantler, in the course of the business carried on by the person—
 - (a) assesses as a total loss a notifiable vehicle registered under this regulation; or
 - (b) assesses as a total loss a notifiable vehicle that is in the State, but is not registered under this regulation or a corresponding law to this regulation.
- (2) The person must give the chief executive the notifiable information for the vehicle before the first of the following happens—
 - (a) 7 days elapse after the person takes possession of the vehicle;
 - (b) the person—
 - (i) demolishes or dismantles the vehicle; or
 - (ii) disposes of the vehicle; or
 - (iii) disposes of any part of the vehicle that has a chassis number or VIN; or
 - (iv) sells the vehicle; or
 - (v) sells any part of the vehicle that has a chassis number or VIN.

Maximum penalty—50 penalty units.

[s 55J]

- (3) The person is not required to act under subsection (2) if someone else has already given the information to the chief executive.
- (4) Despite subsection (3), the person must give the chief executive the notifiable information for the vehicle on demolishing or dismantling the vehicle.

55J Obligation of registered operator or owner of unregistered vehicle to report written-off vehicle

- (1) This section applies if a person, other than a self-insurer, proposes to sell or otherwise dispose of a notifiable vehicle, or a part of a notifiable vehicle that has an identifying number, and—
 - (a) the vehicle is a total loss; and
 - (b) either—
 - (i) the person is the registered operator of the vehicle; or
 - (ii) the vehicle is not registered under this regulation or a corresponding law to this regulation, the person is the owner of the vehicle and the vehicle is in the State.
- (2) The person must give the chief executive the notifiable information for the vehicle, in the approved form, before—
 - (a) disposing of the vehicle; or
 - (b) disposing of any part of the vehicle that has a chassis number or VIN; or
 - (c) selling the vehicle; or
 - (d) selling any part of the vehicle that has a chassis number or VIN.

Maximum penalty—10 penalty units.

- (3) Despite subsection (2), the person is not required to state whether the vehicle is a repairable write-off or a statutory write-off.

-
- (4) The chief executive is taken to have been notified that the vehicle is a repairable write-off unless someone else has already—
 - (a) given the notifiable information for the vehicle to the chief executive; and
 - (b) stated that the vehicle is a statutory write-off.
 - (5) The person is not required to act under subsection (2) if someone else has already given the information to the chief executive.

55K Notifier’s obligation to tell registered operator or owner

- (1) This section applies if—
 - (a) a notifier gives the notifiable information for a notifiable vehicle to the chief executive under this part; and
 - (b) the notifier is not the registered operator or the owner of the vehicle.
- (2) The notifier must tell the registered operator of the vehicle or, if the vehicle is not registered under this regulation or a corresponding law to this regulation, the owner of the vehicle, that the notifier has given the information to the chief executive.

Maximum penalty for subsection (2)—10 penalty units.

55L Obligation on notifiers to attach written-off vehicle label to written-off vehicle

- (1) This section applies if a notifier gives notifiable information for a notifiable vehicle to the chief executive under this part.
- (2) The notifier must, in accordance with subsections (3) to (6), on giving the information to the chief executive, attach to the vehicle a label that meets the chief executive’s specifications for the vehicle.

Maximum penalty—30 penalty units.

[s 55M]

- (3) The label must state whether the vehicle is a repairable write-off or a statutory write-off.
- (4) If the label states that the vehicle is a repairable write-off, the label must also state that a repairable write-off can be registered under this regulation only if it passes a written-off vehicle inspection.
- (5) If the label states that the vehicle is a statutory write-off, the label must also state that a statutory write-off can not be registered under this regulation.
- (6) The label must be attached to the vehicle in a conspicuous position so as to be clearly visible from outside the vehicle.

Examples of when a label is not attached in a conspicuous position—

- label attached to back seat
- label attached to vehicle floor

55M Obligation on registered operator or owner to attach written-off vehicle label to written-off vehicle

- (1) This section applies if the registered operator or the owner of a notifiable vehicle gives the notifiable information for the vehicle to the chief executive under this part.
- (2) The registered operator or owner must, in accordance with subsection (3), attach a label in the approved form to the vehicle.

Maximum penalty—30 penalty units.

- (3) The label must—
 - (a) be attached to the vehicle within 24 hours after the person gives the information to the chief executive; and
 - (b) be attached to the vehicle in a conspicuous position so as to be clearly visible from outside the vehicle.

Examples of when a label is not attached in a conspicuous position—

- label attached to back seat
- label attached to vehicle floor

55N Offence to remove written-off vehicle label

A person must not remove from a vehicle a label attached to the vehicle under this part while the vehicle is recorded in the register as a written-off vehicle, unless the person has a reasonable excuse.

Maximum penalty—30 penalty units.

55O Written-off vehicles must not be used on road

- (1) A person must not use, or permit to be used, on a road a vehicle that is recorded in the register, or in a register kept under a corresponding law to this regulation, as a statutory write-off.

Maximum penalty—20 penalty units.

- (2) A person must not use, or permit to be used, on a road a vehicle that is—
- (a) registered under this regulation or under a corresponding law to this regulation; and
 - (b) recorded in the register, or in a register kept under a corresponding law to this regulation, as a repairable write-off.

Maximum penalty—20 penalty units.

- (3) A person does not commit an offence against subsection (2) if the vehicle is being driven or towed to—
- (a) an AIS under the Vehicle Standards and Safety Regulation for inspection for obtaining an inspection certificate under that regulation; or
 - (b) a written-off vehicle inspection site for obtaining a written-off vehicle inspection report, but only if there is a current inspection certificate for the vehicle under the Vehicle Standards and Safety Regulation; or
 - (c) another place as required by the chief executive.

[s 55P]

Examples for paragraph (c)—

- a place for inspecting by the Queensland Police Service
- a place for road testing by an inspection station
- a place for having an identifying number stamped

Division 3 Written-off vehicle inspections

55P Definition for div 3

In this division—

approval means an approval of a person as—

- (a) an approved written-off vehicle examiner; or
- (b) an approved written-off vehicle nominee.

55Q Approvals

- (1) The chief executive may grant a person an approval.
- (2) A person may apply to the chief executive in the approved form for an approval.
- (3) The chief executive must consider an application for an approval within 28 days after it is received and decide either to—
 - (a) grant the approval; or
 - (b) refuse to grant the approval.
- (4) If the chief executive decides an applicant is a suitable person for an approval, the chief executive must, promptly after making the decision, grant the approval.

55R Conditions of approval

An approval may be granted subject to conditions, including—

-
- (a) for an approval of a person as an approved written-off vehicle examiner—
 - (i) a condition that the approved written-off vehicle examiner may only perform written-off vehicle inspections while employed or otherwise engaged by an entity contracted by the chief executive to operate a written-off vehicle inspection site; and
 - (ii) conditions about the way the approved written-off vehicle examiner is to perform written-off vehicle inspections; or
 - (b) for an approval of a person as an approved written-off vehicle nominee—
 - (i) a condition that the approved written-off vehicle nominee may only supervise the day to day running of written-off vehicle inspections while employed or otherwise engaged by an entity contracted by the chief executive to operate a written-off vehicle inspection site; and
 - (ii) conditions about the way the approved written-off vehicle nominee is to supervise the day to day running of written-off vehicle inspections.

55S Refusing to grant approval

- (1) If the chief executive decides to refuse to grant the approval, the chief executive must give written notice to the applicant of the decision promptly after making the decision.
- (2) The notice must state—
 - (a) the reasons for the refusal; and
 - (b) that the person may ask for the decision to be reviewed under section 66.

55T Approval prescribed for the Act, ss 17B(2) and 18(1)(c)(ii)

An approval under this division is prescribed for sections 17B(2) and 18(1)(c)(ii) of the Act.

[s 55U]

Division 4 Offences relating to written-off vehicle inspections

55U Performing written-off vehicle inspection when not approved

A person must not perform, or purport to perform, a written-off vehicle inspection unless the person is an approved written-off vehicle examiner.

Maximum penalty—80 penalty units.

55V Supervising written-off vehicle inspections when not approved

A person must not supervise, or purport to supervise, the running of written-off vehicle inspections unless the person is an approved written-off vehicle nominee.

Maximum penalty—80 penalty units.

55W Not complying with conditions of approval

A person holding an approval must comply with all conditions stated in the approval.

Maximum penalty—80 penalty units.

55X False or misleading written-off vehicle inspection report

A person must not knowingly or recklessly give a written-off vehicle inspection report to another person that is false or misleading in a material particular.

Maximum penalty—80 penalty units.

55Y Operating place as a written-off vehicle inspection site

A person must not operate, or purport to operate, a place as a written-off vehicle inspection site unless the person is

contracted by the chief executive to operate the place as a written-off vehicle inspection site.

Maximum penalty—80 penalty units.

55Z Performing written-off vehicle inspection at place other than written-off vehicle inspection site

An approved written-off vehicle examiner must not perform a written-off vehicle inspection at a place other than a place operated by a person contracted by the chief executive to operate the place as a written-off vehicle inspection site.

Maximum penalty—80 penalty units.

55ZA Supervising written-off vehicle inspections at place other than written-off vehicle inspection site

An approved written-off vehicle nominee must not supervise the running of written-off vehicle inspections at a place other than a place operated by a person contracted by the chief executive to operate the place as a written-off vehicle inspection site.

Maximum penalty—80 penalty units.

55ZB False advertising or holding out

A person must not falsely advertise or hold out that a particular place is a place where written-off vehicle inspections may be performed.

Maximum penalty—80 penalty units.

[s 56]

Part 8 General

Division 1 Other provisions about number plates and other items

56 Replacement registration items

- (1) This section applies if a registration item for a registered vehicle has been damaged, destroyed, lost or stolen.
- (2) The registered operator of the vehicle must apply to the chief executive in writing for a replacement item within 14 days after discovering the item has been damaged, destroyed, lost or stolen.

Maximum penalty—6 penalty units.

- (3) An application for a replacement number plate must be accompanied by—
 - (a) the relevant plate fee; and
 - (b) either—
 - (i) for the replacement of a damaged number plate—the damaged number plate; or
 - (ii) for the replacement of a destroyed, lost or stolen number plate—a written statement giving details of the loss, theft or destruction.
- (4) On receipt of the application, the chief executive may—
 - (a) record in the register—
 - (i) the day the application was received; and
 - (ii) the damage, destruction, loss or theft of the item; and
 - (b) issue a replacement or updated registration item.
- (5) If the application is for the replacement of a number plate, until the replacement number plate is issued, the registered

operator must attach any remaining plate to the rear of the vehicle.

Maximum penalty—12 penalty units.

- (6) The registration item being replaced ceases to be effective on the issue of the replacement registration item, and the replacement registration item becomes the current registration label or number plate for the vehicle.
- (7) The person must immediately return to the chief executive an item that was a registration item if the person recovers the item after the chief executive has issued a replacement item for it.

Maximum penalty—20 penalty units.

- (8) In this section—

registration item means—

- (a) a current registration label; or
- (b) a number plate.

57 Chief executive may require exchange of number plates

- (1) This section applies if the chief executive—
 - (a) considers the number displayed on a number plate for a vehicle is obscene or indecent; or
 - (b) changes the specifications to which a number plate for a vehicle is manufactured.
- (2) The chief executive may, by written notice given to the registered operator of the vehicle, require the registered operator to return the number plate to the chief executive within the time stated in the notice to be exchanged for another number plate.
- (3) The notice must state the chief executive's reason for requiring the return of the original plate.
- (4) The registered operator must not contravene the requirement unless the person has notified the chief executive in writing that the original plate has been lost, stolen or destroyed.

[s 58]

Maximum penalty—20 penalty units.

- (5) The chief executive must record the exchange of the plate in the register.

58 Chief executive may require return of number plates

- (1) This section applies if the chief executive reasonably believes—
 - (a) a number plate is being used, or has been used, in contravention of this regulation; or
 - (b) a number plate was issued as the number plate for a limousine or taxi and the limousine or taxi is no longer operating under the licence issued under the *Transport Operations (Passenger Transport) Act 1994*.

- (2) The chief executive may, by written notice, require the person to whom the number plate was issued to return the plate to the chief executive within 14 days of the date of the notice (the *return period*).
- (3) The person must return the number plate to the chief executive within the return period.

Maximum penalty—20 penalty units.

- (4) However, if the number plate has been lost, stolen or destroyed, the person does not contravene subsection (3) if the person, within the return period, notifies the chief executive in writing of the details of the loss, theft or destruction.
- (5) The chief executive must record the return of the number plate in the register.
- (6) If this section applies because of subsection (1)(b)—
 - (a) the chief executive may, in the written notice given to a person under subsection (2), also require that the number plate, when returned, be exchanged for a new number plate; and
 - (b) if the number plate is not returned within the return period, the chief executive may issue a replacement number plate for the limousine or taxi.

-
- (7) The number plate being replaced ceases to be effective on the issue of the replacement number plate, and the replacement number plate becomes the current number plate for the vehicle.

59 Property in number plates

- (1) A number plate issued by the chief executive remains the property of the State.
- (2) Subsection (1) applies even if the right to use the number in the number plate is the property of the person to whom the plate was issued.

Division 2 Vehicles temporarily in Queensland

60 Vehicles temporarily in Queensland

- (1) This section applies to a vehicle if the vehicle—
- (a) does not have a garage address in Queensland or has had a garage address in Queensland for not more than 14 days; and
 - (b) is to be used on a road; and
 - (c) either—
 - (i) the vehicle is registered in—
 - (A) another State under a corresponding law to this regulation; or
 - (B) a foreign country under a law of the country about the registration of vehicles used on roads; or
 - (ii) the vehicle is not registered in a way mentioned in subparagraph (i), but may be used on a road under an authority or permit in force under a law of another State relating to the use of unregistered vehicles, including a law relating to dealer plates.

[s 60]

- (2) The vehicle may be used on a road if—
- (a) the vehicle carries and displays all number plates and registration labels it is required to carry and display in the way required by the law—
 - (i) for a vehicle mentioned in subsection (1)(c)(i)—of the other State or foreign country; or
 - (ii) for a vehicle mentioned in subsection (1)(c)(ii)—of the other State; and
 - (b) for a vehicle mentioned in subsection (1)(c)(ii)—the vehicle is used in accordance with the relevant authority or permit, so far as it is capable of being applied to the use of the vehicle outside the other State; and
 - (c) the vehicle is insured—
 - (i) for a vehicle registered in a foreign country—under the *Motor Accident Insurance Act 1994*; or
 - (ii) for a vehicle registered in, or used under an approval issued by, another State—under a contract of insurance made under a law of the State similar to the *Motor Accident Insurance Act 1994*.
- (3) The owner or person in charge of the vehicle must ensure that when the vehicle is used on a road the owner or person is able to produce for inspection on demand by an authorised officer—
- (a) for a vehicle registered in a foreign country—an overseas vehicle permit issued under subsection (6); or
 - (b) otherwise—the approval to use the vehicle under the law of the other State.

Maximum penalty—8 penalty units.

- (4) If the vehicle is a vehicle mentioned in subsection (1)(c)(i)(B), an owner or person in charge of the vehicle who is temporarily in Australia may apply to the chief executive for an overseas vehicle permit for the vehicle.

-
- (5) The application must be in the approved form and accompanied by the relevant fee.
 - (6) The chief executive may issue the permit only if the owner or person satisfies the chief executive that—
 - (a) the vehicle is—
 - (i) registered in a foreign country; and
 - (ii) temporarily in Queensland; and
 - (b) the owner or person has insured the vehicle under subsection (2)(c)(i) and will continue to comply with subsection (2)(a)(i).
 - (7) A category 2 vehicle's garage address is taken to be an address in Queensland if the vehicle is used continuously in Queensland for more than 3 months.

Division 3 Other miscellaneous provisions

61 Sale of unregistered vehicles by dealers

- (1) A dealer must not deliver an unregistered vehicle to a purchaser, other than another dealer, on the sale of the vehicle unless an application to register the vehicle under this regulation has been made.

Maximum penalty—40 penalty units.

- (2) However, the dealer does not contravene subsection (1) if the dealer obtains a written statement from the purchaser that—
 - (a) the vehicle is not to be used on a road; or
 - (b) the vehicle's garage address will not be in Queensland.
- (3) If the vehicle is delivered under subsection (2), the dealer must keep the statement for at least 1 year after the day of delivery of the vehicle to the purchaser.

Maximum penalty—8 penalty units.

[s 62]

62 Authorisation to use unregistered vehicle on roads

- (1) A person may apply in writing to the chief executive for an authorisation to use on a road an unregistered vehicle, or class of unregistered vehicle, including a vehicle or class of vehicle that does not conform with the requirements applying to the vehicle or class under a vehicle law.
- (2) The chief executive may grant the authorisation only if the chief executive is satisfied the use of the vehicle, or class of vehicle, on the road would not—
 - (a) adversely affect road safety; or
 - (b) inconvenience other road users.
- (3) Before granting the authorisation, or as a condition of it, the chief executive may require the applicant to pay the chief executive's costs or estimated costs of the following—
 - (a) assessing the vehicle's route and preparing the relevant plans and estimates;
 - (b) preparing and strengthening road transport infrastructure on the route;
 - (c) repairing, replacing or reconstructing road transport infrastructure on the route;
 - (d) ensuring compliance with a condition or a proposed condition of the authorisation.
- (4) The authorisation must be in writing and state the following particulars—
 - (a) the vehicle or the class of vehicles to which it applies;
 - (b) the roads where the vehicle may be used;
 - (c) the term, not longer than 5 years, for which it is issued;
 - (d) the conditions, if any, on which it is issued.
- (5) If the authorisation is issued on conditions, it is void if the conditions are contravened.

63 Permit to use intercepted unregistered vehicle on road

- (1) This section applies if an authorised officer finds on a road—
 - (a) a stationary unregistered vehicle; or
 - (b) an unregistered vehicle that has been stopped under—
 - (i) section 31 or 32 of the Act; or
 - (ii) the *Police Powers and Responsibilities Act 2000*.
- (2) The authorised officer may issue a permit authorising the use of the vehicle on roads to move it to a stated place if the officer has—
 - (a) issued an infringement notice under the *State Penalties Enforcement Act 1999* for a contravention of section 10; or
 - (b) completed a report for dealing with the contravention at a later time.
- (3) The permit must—
 - (a) be in the approved form; and
 - (b) state the term, not longer than 24 hours, for which it is issued; and
 - (c) state the conditions, if any, on which it is issued; and
 - (d) state—
 - (i) if subsection (2)(a) applies—the number of the infringement notice; or
 - (ii) if subsection (2)(b) applies—that the contravention of section 10 is to be dealt with at a later time either by issuing an infringement notice under the *State Penalties Enforcement Act 1999* or by taking a proceeding by complaint and summons under the *Justices Act 1886*.
- (4) If the permit is issued on a condition, it is void if the condition is contravened.

[s 64]

64 Damaged or dirty number plates

- (1) This section applies if a vehicle's number plate is—
 - (a) damaged and not legible; or
 - (b) dirty and not legible.
- (2) An authorised officer may, by written notice given to the registered operator of the vehicle, or to a person in charge of the vehicle, require the registered operator to—
 - (a) for a damaged number plate—apply to the chief executive, within the time stated in the notice, for a replacement number plate under section 56; or
 - (b) for a dirty number plate—
 - (i) clean the number plate; and
 - (ii) bring the vehicle to the chief executive to be inspected, within the time stated in the notice.
- (3) If the person to whom the notice is given is not the registered operator of the vehicle, the person to whom the notice is given must immediately give the notice to the registered operator of the vehicle, unless the person has a reasonable excuse.

Maximum penalty—6 penalty units.

- (4) The registered operator must not contravene a requirement under subsection (2) unless the registered operator has a reasonable excuse.

Maximum penalty—6 penalty units.

- (5) Despite anything else in this regulation a person who uses, or permits to be used, a vehicle on a road when a number plate required under this regulation to be attached to the vehicle is not attached to the vehicle does not commit an offence if—
 - (a) the number plate is damaged; and
 - (b) an authorised officer, acting under subsection (2)(a), has given the registered operator of the vehicle a written notice directing the registered operator to apply to the chief executive for a replacement number plate under section 56; and

- (c) the damaged number plate and the written notice are being carried in the vehicle; and
- (d) the vehicle is being driven to a place for the purpose of applying, at the place, to the chief executive for a replacement number plate under section 56.

Division 4 Review of decisions

65 Decision to which this division applies

- (1) This division applies to a decision of the chief executive made under this regulation if the decision is one of the following—
 - (a) a decision not to register a vehicle, other than a vehicle that is a statutory write-off;
 - (b) a decision not to renew the registration of a vehicle, other than a vehicle that is a statutory write-off;
 - (c) a decision not to register the transfer of the registration of a vehicle;
 - (d) a decision not to authorise the use of a vehicle on a road under an unregistered vehicle permit;
 - (e) a decision to refuse an overseas vehicle permit for a vehicle;
 - (f) a decision to refuse to grant an approval to a person under part 7A, division 3;
 - (g) a decision to refuse to approve a motorbike as a learner approved motorbike.
- (2) This division also applies to a decision of the chief executive made under this regulation if the decision is to refuse an authorisation under section 62 to use on a road a vehicle or a class of vehicles.

[s 66]

66 Review of decisions

- (1) A person whose interests are affected by a decision to which this division applies may apply, under chapter 4 of the Act, for a review of decision as if the decision were stated in schedule 3 of the Act.
- (2) The person is entitled to receive a statement of reasons for the decision.
- (3) The person may appeal against a reviewed decision to a Magistrates Court.
- (4) Chapter 4 of the Act applies to a review and an appeal under this section.

Division 5 Release of information

67 Definitions for div 5

In this division—

client user, of a public access provider, means a lawyer, insurance company, insolvency entity or statutory entity—

- (a) who has entered into a public access agreement with a public access provider; and
- (b) who has been approved by the chief executive, before or after the commencement of this section, as a suitable entity to obtain extracts from the register of information about vehicles, using on-line computer access; and
- (c) whose approval as a suitable entity has not been withdrawn.

eligible person means—

- (a) an involved person; or
- (b) a statutory entity; or
- (c) the registered operator of a vehicle seeking information from the register about the vehicle; or
- (d) a safety recall agency; or

-
- (e) a person seeking information from the register about a vehicle with the written consent of the registered operator of the vehicle; or
 - (f) an insolvency entity.

give, in relation to information, includes allowing a person to obtain the information.

history certificate see section 67A.

insolvency entity means an entity exercising powers—

- (a) under the *Bankruptcy Act 1966* (Cwlth) in relation to bankruptcy; or
- (b) under the provisions of the Corporations Act relating to external administration.

interstate register means a register kept by another State under a corresponding law to this regulation.

involved person means a person who proposes to commence, or has commenced, litigation.

litigation means a proceeding, or a proposed proceeding, in a court for which information in the register about a particular vehicle is, or may be, of relevance, but only if—

- (a) the proceeding is about—
 - (i) an incident on a road or somewhere else involving the vehicle; or
 - (ii) the bankruptcy or possible bankruptcy of the registered operator of the vehicle, or the application, or the possible application, to the registered operator of the vehicle, of the provisions of the Corporations Act relating to external administration; or
 - (iii) fraudulent activities of the registered operator of the vehicle; or
- (b) the proceeding is before the Family Court of Australia and involves the registered operator of the vehicle; or

[s 67]

- (c) in the course of the proceeding, the court decides information about the registered operator of the vehicle is required, including, for example, to help to finalise the proceeding.

NEVDIS means the database known as the ‘National Exchange of Vehicle and Driver Information System’ that—

- (a) is operated under an arrangement among Queensland and other States; and
- (b) contains information about vehicles and drivers from registers kept by the States participating in the arrangement.

personal information, about a vehicle’s current or previous registered operator, means—

- (a) the person’s name and address; and
- (b) any information that may identify the person.

public access provider means—

- (a) the chief executive; or
- (b) a person who has entered into an agreement with the chief executive to provide on-line computer access to the register to entities approved by the chief executive.

safety recall agency means a vehicle manufacturer conducting a national vehicle safety recall program who requires details from the register to identify the registered operators of particular vehicles.

status certificate see section 67B.

statutory entity means—

- (a) a local government or other entity established under a statute enforcing a law about vehicles or about the parking of vehicles in an area under its control; or
- (b) an entity having lawful access, under another Act, or under administrative arrangements approved by the chief executive, to details kept by the chief executive in the register.

vehicle related information, about a vehicle, means information about the vehicle from the register, or from an interstate register that is available to the chief executive through NEVDIS, but does not include—

- (a) for a vehicle currently recorded in the register or interstate register as a written-off vehicle—
 - (i) personal information about a current or previous registered operator of the vehicle; or
 - (ii) information about a notifier that has given notifiable information for the vehicle; or
 - (iii) information about the location of, or the severity of, damage to the vehicle; or
- (b) for a vehicle not currently recorded in the register or interstate register as a written-off vehicle, personal information about a current or previous registered operator of the vehicle.

vehicle related information provider see section 68A(1).

67A Meaning of *history certificate*

- (1) A *history certificate* is a certificate issued by the chief executive showing information stated in subsection (2) about a vehicle if—
 - (a) the vehicle is or was manufactured on or after 1 January 1989; and
 - (b) the vehicle is registered in Queensland, or was registered in Queensland and is not currently registered in any State.
- (2) For subsection (1), the information is the following vehicle related information about the vehicle to the extent the information is included in the register—
 - (a) the day the vehicle was first registered and the day of any subsequent registration of the vehicle;
 - (b) the day of each transfer of the vehicle's registration, other than a transfer from a dealer to another dealer;

[s 67B]

- (c) the vehicle's engine number and odometer reading at the time of each registration of the vehicle and each transfer of the vehicle's registration, other than a transfer from a dealer to another dealer;
- (d) each purpose the vehicle is or has been used for;
- (e) whether the vehicle is or was recorded as a written-off vehicle and, if so, the relevant day and whether the vehicle was a repairable write-off or statutory write-off;
- (f) the day of each cancellation of the vehicle's registration;
- (g) a postcode indicating the usual place the vehicle is or was kept or the registered operator of the vehicle lives or lived, or a postcode otherwise associated with the vehicle;
- (h) the information that would be included in a status certificate for the vehicle if the status certificate were issued at the time of issuing the history certificate;
- (i) any other vehicle related information decided by the chief executive.

67B Meaning of *status certificate*

- (1) A *status certificate* is a certificate issued by the chief executive showing information stated in subsection (2) about a vehicle if—
 - (a) the vehicle is or was manufactured on or after 1 January 1989; and
 - (b) the vehicle—
 - (i) is registered in Queensland or another State; or
 - (ii) was registered in Queensland or another State and is not currently registered in any State.
- (2) For subsection (1), the information is the following vehicle related information to the extent the information is included in the register or an interstate register available to the chief executive through NEVDIS—

- (a) the State in which the vehicle is or was registered;
- (b) the vehicle's registration number;
- (c) the vehicle's VIN, make, model, engine number, body shape, colour, year of manufacture, seating capacity and odometer reading most recently recorded in the register or interstate register;
- (d) the purpose the vehicle is used for;
- (e) whether the vehicle is fuelled or powered by, or fuelled or powered by a combination of, diesel, electric, gas, kerosene, petrol or steam;
- (f) the number of cylinders or rotors the vehicle has;
- (g) whether the vehicle is currently recorded in the register or interstate register as stolen and, if so, each of the following—
 - (i) the day the vehicle was recorded as stolen;
 - (ii) any reference number used by the Queensland Police Service, or the police service of another State, in relation to the theft of the vehicle that is recorded in the register or interstate register;
- (h) if the vehicle is currently recorded in the register or interstate register as a written-off vehicle and is not currently recorded in the register or interstate register as having passed a written-off vehicle inspection, each of the following—
 - (i) whether the vehicle is a repairable write-off or statutory write-off;
 - (ii) the day the vehicle was recorded as a written-off vehicle;
 - (iii) the State in which the vehicle is recorded as a written-off vehicle;
 - (iv) information recorded in the register or interstate register about the cause of damage to the vehicle;

[s 68]

- (i) if the vehicle is currently recorded in the register or interstate register as having passed a written-off vehicle inspection, each of the following—
 - (i) that the vehicle has passed a written-off vehicle inspection;
 - (ii) the date of the written-off vehicle inspection;
 - (iii) the State in which the vehicle is recorded as having passed the written-off vehicle inspection;
 - (iv) information recorded in the register or interstate register about the cause of damage to the vehicle;
- (j) any expiry day relevant to the vehicle's registration or, if the vehicle's registration has been cancelled, the fact the registration has been cancelled;
- (k) a postcode indicating the usual place the vehicle is kept or the registered operator of the vehicle lives, or a postcode otherwise associated with the vehicle;
- (l) any other vehicle related information decided by the chief executive.

68 Release of information on payment of fee

- (1) The chief executive may, in the circumstances approved by the chief executive, give an extract from the register of information about a vehicle to an eligible person, or a person acting on the eligible person's behalf, if the eligible person, or the person acting on the eligible person's behalf—
 - (a) submits a request for the information to the chief executive in the approved form; and
 - (b) pays the relevant fee.
- (2) The eligible person, or the person acting on the eligible person's behalf, must not use or disclose information obtained under subsection (1) other than in accordance with conditions approved by the chief executive for the use and disclosure of the information and advised to the eligible person or the

person acting on the eligible person's behalf when, or before, the information is obtained.

Maximum penalty—20 penalty units.

- (3) A public access provider may allow a client user of the provider to obtain an extract from the register of information about a vehicle, using on-line computer access, if the client user—
 - (a) pays the public access provider the relevant fee; and
 - (b) obtains the extract only in the circumstances approved by the chief executive for obtaining the extract.
- (4) The client user must not use or disclose information obtained under subsection (3) other than in accordance with conditions approved by the chief executive for the use and disclosure of the information and advised to the client user when, or before, the information is obtained.

Maximum penalty—20 penalty units.

68AA Release of information to toll road operator, local government tollway operator and other persons

- (1) The chief executive may, under an arrangement in writing entered into between the chief executive and a toll road operator or local government tollway operator, give an extract from the register of information about a vehicle to—
 - (a) the operator; or
 - (b) a person acting for the operator.
- (2) The arrangement must—
 - (a) include conditions imposed by the chief executive about—
 - (i) the giving of the information; and
 - (ii) the use and disclosure of the information; and
 - (b) provide for payment to the chief executive of the reasonable amount decided by the chief executive for giving the information.

[s 68A]

- (3) A toll road operator or local government tollway operator given information about a vehicle under an arrangement as mentioned in subsection (1) must not use or disclose the information other than under the conditions stated in the arrangement for the use and disclosure.

Maximum penalty—20 penalty units.

- (4) If a person who is acting for a toll road operator or local government tollway operator is given information about a vehicle under an arrangement as mentioned in subsection (1), the person must not use or disclose the information other than under the conditions—

- (a) stated in the arrangement for the use and disclosure; and
(b) advised to the person when, or before, the information is given.

Maximum penalty—20 penalty units.

- (5) Information about a vehicle that may be released under subsection (1) includes personal information about the vehicle's current or previous registered operator.

- (6) In this section—

local government tollway operator see the *Transport Infrastructure Act 1994*, section 105B.

toll road operator see the *Transport Infrastructure Act 1994*, section 92.

68A Release of vehicle related information

- (1) This section applies to the following (each of whom is a *vehicle related information provider*)—

- (a) the chief executive;
(b) a person who has entered into an agreement with the chief executive that provides the person will give vehicle related information about a vehicle to other persons.

- (2) A vehicle related information provider may give a person vehicle related information about a vehicle, including giving

the person information by issuing a history certificate or status certificate and giving it to the person, if—

- (a) the person pays the vehicle related information provider the fee or amount provided for under section 68B; and
 - (b) the information is given to the person only in the circumstances approved by the chief executive for giving the information.
- (2A) However, subsection (2)(a) does not apply to the chief executive in giving information to a person under section 68AA.

Note—

See section 68AA(2)(b) about payment to the chief executive for giving information to the person under that section.

- (3) A person given information under subsection (2) must not use or disclose the information other than in accordance with any conditions approved by the chief executive for the use or disclosure of the information and advised to the person when, or before, the information is given.

Maximum penalty for subsection (3)—20 penalty units.

68B Fee or amount payable to vehicle related information provider

- (1) This section provides for the fee or amount to be paid to a vehicle related information provider as stated in section 68A(2)(a).
- (2) The fee or amount is—
- (a) if the vehicle related information provider is the chief executive and a fee for giving the information to the person is stated in schedule 3, part 2, the fee stated in the schedule; or
 - (b) if the vehicle related information provider is the chief executive and paragraph (a) does not apply, a reasonable amount decided by the chief executive; or

[s 69]

- (c) if the vehicle related information provider is not the chief executive, a reasonable amount decided by the vehicle related information provider.

Part 9 Fees

Division 1 General

69 Fees

- (1) The registration fees payable for a category 1 vehicle are stated in schedule 1.
- (2) The registration fees payable for a category 2 vehicle are stated in schedule 2.
- (3) Other fees payable under this regulation are stated in schedule 3.
- (4) The fees payable under schedules 1 to 3 for vehicle registration for a term less than 1 year are to be adjusted in proportion to the number of days in the term.
- (5) To remove any doubt, it is declared that subsection (3) does not apply to an amount payable to the chief executive for giving information under section 68AA(1).

Note—

See section 68AA(2)(b) about payment to the chief executive for giving information under that section.

70 Charging categories

- (1) If a category 2 vehicle falls within 2 or more categories in schedule 2, the registration fee for the vehicle is the higher or highest of the fees that could apply to the vehicle.
- (2) To decide the number of trailers a prime mover or truck may tow—

- (a) a dolly and a semitrailer, when used together, are taken to be 1 trailer; and
 - (b) a low loader and low loader dolly, when used together, are taken to be 1 trailer.
- (3) If a category 2 vehicle is registered according to a particular type in schedule 2, a person must not use the vehicle, or, whether or not the person is the vehicle's registered operator, permit another person to use the vehicle, as a vehicle of another type to which a higher registration fee applies.

Maximum penalty—80 penalty units.

Example of subsection (3)—

If a vehicle is not registered to tow a trailer, the vehicle cannot be used to haul a trailer unless its registration is changed and the relevant registration fee is paid.

- (4) For applying schedule 2 (other than schedule 2, part 1, item 2)—
- (a) 2 axles with less than 1m between them are taken to be 1 axle; and
 - (b) 3 axles with not more than 2m between the first and third axles are taken to be 2 axles; and
 - (c) 4 axles with not more than 3.2m between the first and fourth axles are taken to be 3 axles.
- (5) For applying subsection (4) in relation to a vehicle, the distance between axles is measured between the centres of the wheels—
- (a) mounted on the axles; and
 - (b) parallel to the length of the vehicle.

[s 71]

Division 2 Vehicles exempted from registration fees

71 Exemption from payment of fee

- (1) The chief executive may grant an exemption from the payment of the following fees otherwise payable under this regulation—
 - (a) the registration fee payable for the registration of a vehicle or dealer plate if the registered operator is an association established solely for a charitable purpose within the meaning of the *Collections Act 1966* and the vehicle or dealer plate is used solely for that purpose;
 - (b) the registration fee payable for the registration of a vehicle if the registered operator is—
 - (i) a consulate; or
 - (ii) the head of a consulate; or
 - (iii) a career officer of a consulate; or
 - (iv) the head of an honorary consular mission;
 - (c) the registration fee payable for the registration of a vehicle that is a motorised wheelchair used by a person with a disability affecting the person's mobility.
- (2) An exemption under subsection (1)(b) may be granted only with the approval of the chief executive of the department within which the *Public Service Act 2008* is administered.
- (3) The registered operator of a vehicle or dealer plate must apply for the exemption in the approved form.
- (4) A person who is granted an exemption from the payment of the registration fee for a vehicle or dealer plate must notify the chief executive in writing—
 - (a) before using the vehicle or dealer plate for a purpose other than the purpose for which the exemption was granted; or
 - (b) within 14 days—

-
- (i) after a material change in the circumstances under which the exemption was granted; or
 - (ii) of the sale or other transfer of the vehicle.

Maximum penalty—20 penalty units.

- (5) On receipt of the notice, the chief executive may reassess the registration fee payable for the registration of the vehicle, without the exemption, for the term (the *unexpired term*)—
 - from when the registered operator or vehicle ceased to be eligible for the exemption
 - to the end of the current registration of the vehicle.
- (6) The chief executive may, by written notice, require the amount of the reassessed fee for the unexpired term to be paid by—
 - (a) if the notice is given under subsection (4)(a) or (b)(i)—the person to whom the exemption was granted; or
 - (b) if the notice is given under subsection (4)(b)(ii)—the person to whom the vehicle is sold or otherwise transferred.
- (7) The person to whom the notice is directed must, within 28 days after the chief executive gives the notice, pay the amount assessed.

Maximum penalty—60 penalty units.

Division 3 Concessional registration fees for certain category 1 vehicles

72 Concessional registration fees—category 1 vehicles

- (1) The chief executive may grant the registered operator of a vehicle mentioned in schedule 1, part 2, a concessional registration fee for the vehicle.

[s 72]

- (2) An application for the concession must be in the approved form.
- (3) A person who is granted a concessional registration for a vehicle must notify the chief executive in writing—
 - (a) before using the vehicle for a purpose other than the purpose for which the concession was granted; or
 - (b) within 14 days—
 - (i) after a material change in the circumstances under which the concession was granted; or
 - (ii) of the sale or other transfer of the vehicle.

Maximum penalty—20 penalty units.

- (4) On receipt of the notice or prescribed concession information about the person, the chief executive may reassess the registration fee payable for the vehicle's registration, without the concession, for the term (the *unexpired term*)—
 - from when the registered operator or vehicle ceased to be eligible for the concession
 - to the end of the vehicle's current registration.
- (5) The chief executive may, by written notice, require the amount of the reassessed fee for the unexpired term to be paid by—
 - (a) if the notice is given under subsection (3)(a) or (b)(i) or because of the prescribed concession information—the person to whom the concession was granted; or
 - (b) if the notice is given under subsection (3)(b)(ii)—the person to whom the vehicle is sold or otherwise transferred.
- (6) The person to whom the notice is directed must, within 28 days after the chief executive gives the notice, pay the amount assessed.

Maximum penalty—20 penalty units.

Division 4 Concessional registration fees for category 2 vehicles

73 Concessional registration fees—primary production vehicles

- (1) The chief executive may grant a primary producer the concessional registration fee provided for in schedule 2, part 2 for the registration of a primary production vehicle.
- (2) An application for the concession must be in the approved form.
- (3) A primary producer who is granted concessional registration for a primary production vehicle must not use, or permit to be used, the vehicle for a purpose other than for carrying on the producer's business as a primary producer.

Maximum penalty—60 penalty units.

- (3A) A primary producer who is granted concessional registration for a primary production vehicle must, within 14 days of a sale or other transfer of the vehicle, give the chief executive written notice of the sale or other transfer.

Maximum penalty—60 penalty units.

- (3B) A primary producer who is granted concessional registration for a primary production vehicle and who intends to use the vehicle for a purpose other than for carrying on the producer's business as a primary producer may advise the chief executive of the intention.

- (4) On receipt of the notice or advice, the chief executive may reassess the registration fee payable for the registration of a vehicle mentioned in subsection (3A) or (3B), without the concession, for the term (the *unexpired term*)—
 - from when the primary producer ceased to be eligible for the concession or the end of the day the chief executive received the notice or advice
 - to the end of the vehicle's current registration.

[s 74]

- (5) The chief executive may, by written notice, require any amount by which the reassessed fee is more than the fee already paid for the unexpired term to be paid by—
 - (a) the primary producer who gave the advice; or
 - (b) the person to whom the vehicle mentioned in the notice is sold or otherwise transferred.
- (6) The person to whom the notice is directed must, within 28 days after the chief executive gives the notice, pay the amount assessed.

Maximum penalty—60 penalty units.

74 Concessional registration fee for motorised caravan for card holders

- (1) The chief executive may grant a card holder a concessional registration fee provided for in schedule 2, part 2 for the registration of a motorised caravan owned by the person.
- (2) An application for the concession must be in the approved form.
- (3) A person who is granted a concessional registration as a card holder for a motorised caravan must give the chief executive written notice—
 - (a) of ceasing to be a card holder, within 14 days after the cessation; or
 - (b) of the sale or other transfer of the caravan within 14 days after the sale or other transfer.

Maximum penalty—20 penalty units.

- (4) On receipt of the notice or prescribed concession information about the person, the chief executive may reassess the registration fee payable for the caravan's registration, without the concession, for the term (the *unexpired term*)—
 - from when the person ceased to be eligible for the concession
 - to the end of the caravan's current registration.

-
- (5) The chief executive may, by written notice, require any amount by which the reassessed fee is more than the fee already paid for the unexpired term to be paid by—
 - (a) if the person’s notice is given under subsection (3)(a) or because of the prescribed concession information—the person; or
 - (b) if the person’s notice is given under subsection (3)(b)—the person to whom the caravan is sold or otherwise transferred.
 - (6) The person to whom the notice is directed must, within 28 days after the chief executive gives the notice, pay the amount assessed.

Maximum penalty—20 penalty units.

75 Concessional registration fees for other vehicles

- (1) The chief executive may grant a person a concessional registration fee provided for in schedule 2, part 2, items 1 and 2 for the registration of a vehicle.
- (2) An application for the concession must be in the approved form.
- (3) A person who is granted concessional registration for a vehicle must not use, or permit to be used, the vehicle for a purpose other than the purpose for which the concession was granted.

Maximum penalty—60 penalty units.

- (3A) A person who is granted concessional registration for a vehicle must, within 14 days of a sale or other transfer of the vehicle, give the chief executive written notice of the sale or other transfer.

Maximum penalty—60 penalty units.

- (3B) A person who is granted concessional registration for a vehicle and who intends to use the vehicle for a purpose other than the purpose for which the concession was granted may advise the chief executive of the intention.

[s 76]

- (4) On receipt of the notice or advice, the chief executive may reassess the registration fee payable for the registration of a vehicle mentioned in subsection (3A) or (3B), without the concession, for the term (the *unexpired term*)—
- from when the person ceased to be eligible for the concession or the end of the day the chief executive received the notice or advice
 - to the end of the vehicle’s current registration.
- (5) The chief executive may, by written notice, require any amount by which the reassessed fee is more than the fee already paid for the unexpired term to be paid by—
- (a) the person who gave the advice; or
 - (b) the person to whom the vehicle mentioned in the notice is sold or otherwise transferred.
- (6) The person to whom the notice is directed must, within 28 days after the chief executive gives the notice, pay the amount assessed.

Maximum penalty—60 penalty units.

Part 10 Other offence provisions

76 Offences involving registration certificates etc.

- (1) A person must not, unless the person has a reasonable excuse—
- (a) make, sell or have in the person’s possession anything that purports to be, but is not, a registration certificate, registration label, number plate or permit; or
 - (b) alter or deface a registration certificate, registration label, number plate or permit.

Maximum penalty—40 penalty units.

-
- (2) A person must not, unless the person has a reasonable excuse, use, or permit to be used, on a road, a vehicle if—
- (a) a registration certificate, registration label, number plate or permit for the vehicle has been unlawfully altered; or
 - (b) a registration certificate, registration label, number plate or permit for the vehicle has been defaced; or
 - (c) a reflectorised number plate for the vehicle has been repainted in any way, for example, to repair stone chips or other damage; or
 - (d) any writing, mark, or colour on a registration certificate, registration label, number plate or permit for the vehicle is not clearly legible; or
 - (e) a registration label, number plate or permit attached to the vehicle was issued for another vehicle; or
 - (f) a registration label or number plate attached to the vehicle has been recorded in the register as having been cancelled, lost, stolen, destroyed or damaged; or
 - (g) a registration label, number plate or permit required under this regulation to be attached to the vehicle—
 - (i) is not attached to the vehicle; or
 - (ii) is attached to the vehicle, but not in the way required under this regulation; or
 - (h) a registration label still attached to the vehicle should have been taken off the vehicle under section 33(7); or
 - (i) a permit required under section 50(5)(a) to be carried by the driver of the vehicle is not being carried by the driver of the vehicle; or
 - (j) a permit required under section 50(5)(b) to be carried in the vehicle is not being carried in the vehicle.

Maximum penalty—16 penalty units.

- (3) In this section a reference to a registration certificate, registration label, number plate or permit is a reference to a

[s 77]

registration certificate, registration label, number plate or permit issued—

- (a) by the chief executive under this regulation; or
- (b) under a corresponding law to this regulation; or
- (c) under a law of a foreign country about the registration of vehicles.

77 Requirement to remove unlawful registration item

(1) An authorised officer may require a person in charge of a vehicle to take a registration item from the vehicle, and to deliver it to the authorised officer, if the authorised officer believes on reasonable grounds that—

- (a) under this regulation, the use of the vehicle on a road is prohibited; or
- (b) the registration item was not lawfully issued for the vehicle; or
- (c) the registration item is recorded in the register as having been cancelled, lost, stolen, destroyed or damaged.

(2) The person must not contravene the requirement unless the person has a reasonable excuse.

Maximum penalty—16 penalty units.

(3) In this section—

registration item means—

- (a) a registration certificate, registration label, number plate, permit or similar item; or
- (b) an item purporting to be an item mentioned in paragraph (a).

Part 11 Transitional provisions

Division 1 Transitional provisions for Transport Operations (Road Use Management—Vehicle Registration) Regulation 1999

78 Purpose of pt 11

This part provides for the transition from the former regulation to this regulation.

79 Definition for pt 11

In this part—

former regulation means the *Transport Infrastructure (Roads) Regulation 1991* in force immediately before its expiry under section 93A of the Act.

80 Continuation of registration and other authorities under former regulation

- (1) A vehicle that is registered under the former regulation immediately before the commencement of this section is taken to be registered under this regulation for the unexpired term of its registration under the former regulation, unless the registration is sooner cancelled under this regulation.
- (2) On the commencement of this section, a number plate, registration certificate or registration label that was issued for a vehicle that is registered under the former regulation immediately before the commencement of this section and that is current immediately before the commencement of this section is taken to be a current number plate, certificate or label for the vehicle under this regulation.
- (3) A limited use permit issued for a vehicle under section 34 of the former regulation and current immediately before the

[s 81]

commencement of this section continues, for the unexpired term of the permit, to have effect as an unregistered vehicle permit issued for the vehicle under section 50.

- (4) An approval issued for a vehicle under section 44 of the former regulation and current immediately before the commencement of this section continues, for the unexpired term of the approval, to have effect as an authorisation issued for the vehicle under section 62.
- (5) A permit issued for a vehicle under section 44A of the former regulation and current immediately before the commencement of this section continues, for the unexpired term of the permit, to have effect as a permit issued for the vehicle under section 63.

81 Postponement of particular changes until 31 December 1999

Until the end of 31 December 1999—

- (a) the following vehicles are taken to be included in the list of vehicles that are exempt vehicles under section 4—
 - (i) all agricultural machines;
 - (ii) all items of equipment used for the construction of works for, or maintenance of, road transport infrastructure;
 - (iii) all fire-engines;
 - (iv) all motorised golf buggies; and
- (b) despite the expiry of the former regulation, the supply of extracts from the register is to continue to happen under the following provisions of the former regulation as if the regulation had not expired—
 - (i) section 13(3);
 - (ii) schedule 1, part 4, items 2 to 4.

82 Limited use plates under former regulation

- (1) This section applies to a vehicle that, immediately before the commencement of this section, is the subject of a current authorisation under section 35 of the former regulation for the use of the vehicle on a road on the basis of the issue of a limited use plate.
- (2) Section 35 of the former regulation, together with any other provisions of the former regulation necessary for giving section 35 continued effect, continues to apply to the vehicle until the expiry of the term for which the limited use plate was issued.

83 Position for attaching registration label to certain trailers

Section 33 does not apply to a trailer that is a category 2 vehicle in relation to a registration label attached under section 22 of the former regulation before the commencement of this section.

Division 2 Transitional provision for written-off vehicle amendments

84 Registration of vehicle recorded as a written-off vehicle under corresponding law

- (1) This section applies if—
 - (a) immediately before the commencement of this section, a vehicle is recorded in a register kept under a corresponding law to this regulation as a written-off vehicle; and
 - (b) after the vehicle was recorded in the register kept under the corresponding law as a written-off vehicle, but before the commencement of this section, the vehicle was registered under this regulation, whether or not it is still registered.

[s 84]

- (2) For this regulation, the vehicle is taken not to be recorded as a written-off vehicle in the register kept under the corresponding law.

Schedule 1 Category 1 vehicle registration fees

section 69(1)

Part 1 Category 1 vehicle registration fees for 1 year

	\$
1 Motor vehicle with a GVM not over 4t—	
(a) 1, 2 or 3 cylinders, electric or steam	206.35
(b) 4 cylinders or 2 rotors	262.45
(c) 5 or 6 cylinders or 3 rotors.	415.60
(d) 7 or 8 cylinders	581.90
(e) 9–12 cylinders	682.50
2 Motor vehicle, other than a motorised caravan or bus, with a GVM over 4t but not over 4.5t	652.30
3 Motorised caravan with a GVM over 4t but not over 4.5t.	474.15
4 Bus with a GVM over 4t but not over 4.5t	650.10
5 Mobile machinery or equipment—	
(a) GVM not over 1t	147.95
(b) GVM over 1t but not over 2t	202.85
(c) GVM over 2t but not over 3t	257.75
(d) GVM over 3t but not over 4t	312.60
(e) GVM over 4t but not over 4.5t.	317.00
6 Motorbike	91.30
7 Trailer—	
(a) ATM not over 1.02t.	82.70
(b) ATM over 1.02t but not over 4.5t	157.50

Note—

Under schedule 4, definition *caravan*, a caravan is a type of trailer.

Schedule 1

Part 2 **Category 1 vehicle concessional registration fees for 1 year**

	\$
1 Ambulance vehicle	74.00
2 Vehicle, with distance and road use limits imposed by the chief executive, owned by a primary producer and used only in the owner’s business as a primary producer—	
(a) motor vehicle with a GCM or GVM not over 4t	78.15
(b) motor vehicle with a GCM or GVM over 4t but not over 4.5t	114.25
(c) trailer with an ATM not over 4.5t	78.15
3 One motor vehicle (other than a conditionally registered vehicle or mobile machinery or equipment) registered in the name of the holder of a seniors card	the greater of the following—
	(a) 50% of the part 1 fee;
	(b) 74.00
4 Motor vehicle with a GCM or GVM not over 4t mentioned in schedule 3A, other than a conditionally registered vehicle	74.00
5 Motor vehicle with a GCM or GVM over 4t but not over 4.5t mentioned in schedule 3A, other than a conditionally registered vehicle	the greater of the following—
	(a) 25% of the part 1 fee;
	(b) 74.00

		\$
6	One motor vehicle (other than a conditionally registered vehicle or mobile machinery or equipment) registered in the name of the holder of a pensioner concession card issued before 1 July 1994—	
	(a) with a GCM or GVM not over 4t, in circumstances mentioned in the Transport concession policy	74.00
	(b) with GVM over 4t but not over 4.5t, in circumstances mentioned in the Transport concession policy	the greater of the following—
		(a) 25% of the part 1 fee;
		(b) 74.00
7	One motor vehicle (other than a conditionally registered vehicle or mobile machinery or equipment) registered in the name of the holder of a pensioner concession card issued after 30 June 1994, with a GCM or GVM not over 4.5t, in circumstances mentioned in the Transport concession policy	the greater of the following—
		(a) 50% of the part 1 fee;
		(b) 74.00
8	Special interest vehicle	74.00

Schedule 2 Category 2 vehicle registration fees

section 69(2)

Part 1 Category 2 vehicle registration fees for 1 year—nationally regulated fees

1 Vehicles

Vehicle type	2 axle	3 axle	4 axle	5 or more axles
Trucks—				
• Truck (type 1)	\$392	\$673	\$673	\$673
• Truck (type 2)	\$673	\$886	\$886	\$886
• Short combination truck	\$673	\$886	\$1644	\$1644
• Medium combination truck	\$6014	\$6014	\$6496	\$6496
• Long combination truck	\$8293	\$8293	\$8293	\$8293
Prime movers—				
• Short combination prime mover	\$1032	\$4056	\$4460	\$4460
• Multi-combination prime mover	\$7276	\$7276	\$8003	\$8003

2 Trailers

Trailer type	single axle or single axle group	tandem axle group	tri-axle group	quad-axle group	multi-axle group
Pig trailer	\$392	\$784	\$1176	\$1568	\$392 x number of axles
Dog trailer	\$392	\$784	\$1176	\$1568	\$392 x number of axles
Semitrailer	\$392	\$784	\$1254	\$1672	\$418 x number of axles
B-double lead trailer or B-triple lead trailer or B-triple middle trailer	\$392	\$2352	\$3684	\$4912	\$1228 x number of axles
Converter dolly or low loader dolly	\$392	\$784	\$1176	\$1568	\$392 x number of axles

3 Buses

Bus type	2 axle	3 axle	4 or more axles
Bus (type 1)	\$392	—	—
Bus (type 2)	\$392	\$2154	\$2154
Articulated bus	—	\$392	\$392

4 Special purpose vehicles

Special purpose vehicle (type o)	\$320 + (\$320 x number of axles in excess of 2)
Special purpose vehicle (type p)	No registration fee
Special purpose vehicle (type t)	\$256

Part 1A Category 2 vehicle registration fees for 1 year—non-nationally regulated fees

Vehicle type	2 axle	3 axle	4 axle	5 or more axles
Motorised caravans	\$460.30	\$920.55	\$1380.80	\$1380.80

Part 2 Category 2 vehicle concessional registration fees for 1 year

- 1 The percentage of the registration fee payable under a concessional registration for a category 2 vehicle mentioned in schedule 3A (other than a special interest vehicle, motorised caravan or a vehicle that may be conditionally registered) is as follows—
 - (a) for a truck with 2 or 3 axles—50%;
 - (b) for a truck with 4 or more axles—25%;
 - (c) for a short combination prime mover, or a short, medium or long combination truck, with 2 axles—50%;

-
- (d) for a multi-combination prime mover with 2 axles—25%;
 - (e) for a short or multi-combination prime mover, or a short, medium or long combination truck, with 3 or more axles—25%;
 - (f) for a trailer with 1 axle—50%;
 - (g) for a trailer with 2 axles—35%;
 - (h) for a trailer with 3 or more axles—30%;
 - (i) for a special purpose vehicle—25%;
 - (j) for a caravan, mobile library, mobile workshop, mobile laboratory or mobile billboard—35%;
 - (k) for a bus—50%.
- 2 The concessional registration fee for a special interest vehicle is \$74.00.
- 3 The percentage of the registration fee payable under a concessional registration for a motorised caravan owned by a card holder is—
- (a) if the card holder holds a seniors card—50%; or
 - (b) if the card holder holds a pensioner concession card issued—
 - (i) before 1 July 1994—25%; or
 - (ii) after 30 June 1994—50%.
- 4 The concessional registration fee for a vehicle, with distance and road use limits imposed by the chief executive, owned by a primary producer and used only in the owner’s business as a primary producer, is—
- (a) for a motor vehicle—\$47.90; or
 - (b) for a trailer—\$114.25.

Schedule 3 Other fees

section 69(3)

Part 1 Plate fees

	\$
1 Limousine number plates	34.30
2 Fire and rescue appliance number plates	38.55
3 Accessory plate	22.75
4 Another number plate	22.75
5 Replacement of any of the following, unless item 6 applies—	
(a) dealer plate	84.45
(b) limousine number plates	34.30
(c) another number plate	22.75
6 Replacement plate or pair of plates with the same number and design as the replaced plate or plates	22.75 plus manufacturing costs

Part 2 Miscellaneous fees

	\$
1 Application for—	
(a) transfer of registration	21.05
(b) unregistered vehicle permit, for each day	25.25
2 Notifying chief executive of transfer of personalised number plate	76.60
3 Extract from the register for use in a vehicles safety recall, for each vehicle to a maximum of \$5000	1.40

	\$
4	Extract from the register through a public access provider—
	(a) for each vehicle, if the vehicle’s registration number is supplied 13.50
	(b) if the name and address of the person in whose name a vehicle is registered are provided, but not the vehicle’s registration number, for each list of vehicle registration numbers supplied 8.10
	(c) for each vehicle, if information about the vehicle is supplied by electronic or disk file 8.10
	(d) for each vehicle, for each extract certified by the chief executive 21.60
5	Extract from the register other than under item 3 or 4—
	(a) for each vehicle, if the vehicle’s registration number, VIN, chassis number or engine number is supplied 13.50
	(b) if the name and address of the person in whose name a vehicle is registered are provided, but not the vehicle’s registration number, for each list of vehicle registration numbers supplied 8.10
	(c) for each vehicle, for each extract from archival records 21.60
	(d) for each vehicle, for each extract certified by the chief executive 21.60
6	Surcharge for processing an application for registration, other than conditional registration, for less than 1 year—
	(a) category 1 vehicle 8.10
	(b) category 2 vehicle 28.40
7	Surcharge for processing an application for renewal of registration, other than conditional registration, for less than 1 year if payable under section 37A—
	(a) category 1 vehicle 8.10
	(b) category 2 vehicle 28.40
8	Surcharge for processing concessional registration in relation to an application for registration for less than 1 year for a category 1 vehicle 4.00

Schedule 3

	\$
9 Surcharge for processing concessional registration in relation to an application for renewal of registration for less than 1 year for a category 1 vehicle if payable under section 37A	4.00
10 Surcharge for processing an application for conditional registration for less than 1 year	8.10
11 Customising a number plate	38.35
12 Traffic improvement fee for a category 1 vehicle	45.80
13 Registration administration fee for a category 2 vehicle other than a trailer	55.40
14 Registration fee for dealer plate.	442.00
15 Administration fee payable to the chief executive by an entity contracted by the chief executive to operate a written-off vehicle inspection site, for each written-off vehicle inspection	55.55
16 Fee payable to the chief executive in relation to a history certificate—	
(a) if the chief executive provides information for the certificate to another vehicle related information provider	14.50
(b) if the chief executive provides the certificate to a person other than a vehicle related information provider	20.25
17 Fee payable to the chief executive in relation to a status certificate—	
(a) if the chief executive provides information for the certificate to another vehicle related information provider	8.20
(b) if the chief executive provides the certificate to a person other than a vehicle related information provider	14.50

Schedule 3A Vehicles for particular concessional registration fees

schedule 1, part 2, items 4 and 5 and schedule 2, part 2, item 1

1 Special interest vehicle

A special interest vehicle.

2 Local government vehicle

A vehicle whose registered operator is a local government.

3 Community service organisation vehicle

A vehicle, whose registered operator is a community service organisation, used on a road solely to give help to persons in distress.

4 Vehicle used only in particular areas

A vehicle used on a road only in 1 or more of the following areas—

- Aurukun Shire
- the community government areas of the following community governments under the *Local Government (Community Government Areas) Act 2004*—
 - Doomadgee Shire Council
 - Kowanyama Shire Council
 - Pormpuraaw Shire Council
 - Yarrabah Shire Council
- a coastal island that is not joined to the mainland by a bridge
- the area north of the Archer River from the western to the eastern end of the river

- the area north of a straight line from the eastern end of the Archer River to Friendly Point.

Editor's note—

Friendly Point is on the east coast of Queensland north of Cooktown.

5 Vehicle used solely to cross roads within an agricultural property

A vehicle—

- (a) whose registered operator, or at least 1 of whose registered operators, is the sole or joint operator of an agricultural property; and
- (b) used on a road solely to cross roads within the property that need to be crossed by the vehicle to operate the property.

6 Vehicle used solely to travel between 2 agricultural properties, or 2 mining properties, directly across the road from each other

A vehicle if—

- (a) its registered operator, or at least 1 of its registered operators, is the sole or joint operator of—
 - (i) an agricultural property, or a property solely or partly used for mining, with a frontage (the *first frontage*) to a side of a road; and
 - (ii) a separate agricultural property, or property solely or partly used for mining, with a frontage (the *second frontage*) to the opposite side of the road; and
- (b) part or all of the first frontage is directly opposite part or all of the second frontage; and
- (c) the vehicle is used on a road solely to travel along the road for no more than 2 kilometres between the properties.

Example of the travel—

Travel along the road for 2km between a gated entry and exit on 1 of the properties to an undeveloped entry and exit on the other property.

7 Vehicle used solely for fencing of primary producer's property

A vehicle—

- (a) whose registered operator, or at least 1 of whose registered operators, is the sole or joint operator of a property used for carrying on the registered operator's business as a primary producer; and
- (b) used on a road solely to travel on roads within the property, or onto which the property has a frontage, to build, maintain or remove the property's fences.

8 Vehicle used solely as a mobile workshop for carrying on business of bee keeping

A vehicle used on a road solely as a mobile workshop for carrying on the vehicle's registered operator's business of bee keeping.

9 Vehicle used solely to cross roads within a mining property

A vehicle—

- (a) whose registered operator, or at least 1 of whose registered operators, is the sole or joint operator of a property solely or partly used for mining; and
- (b) used on a road solely to cross roads within the property that need to be crossed by the vehicle to perform the mining.

10 Vehicle used solely to carry on business of oil, mineral or water exploration

A vehicle—

- (a) permanently fitted with oil, mineral or water exploration equipment; and
- (b) used on a road solely for carrying on the vehicle's registered operator's business of exploring for oil, minerals or water.

11 Vehicle used solely for carrying on business of prospecting in particular areas

- (1) A vehicle used on a road solely for carrying on the vehicle's registered operator's business of prospecting in 1 or more of the areas mentioned in schedule 3B.
- (2) For schedule 3B, a reference to a shire or city by name is a reference to the shire or city of that name declared as a local government area under the *Local Government Act 1993* as in force immediately before the changeover day.

Notes—

- 1 Under the *Local Government Act 1993* as in force immediately before the changeover day, shires and cities were described in the *Local Government (Areas) Regulation 2005*, schedule 1 as in force immediately before the changeover day.
- 2 Each map mentioned in the *Local Government (Areas) Regulation 2005*, schedule 1 as in force immediately before the changeover day can be—
 - (a) accessed by members of the public, free of charge, on the department's website; or
 - (b) purchased from any office of the department in which the *Survey and Mapping Infrastructure Act 2003* is administered.

Editor's note—

At the commencement of this subsection, the department's website was <www.transport.qld.gov.au>.

- (3) In this section—

changeover day means 15 March 2008.

Note—

15 March 2008 is the changeover day declared under the *Local Government Act 1993*, section 159YE(2) for all new, adjusted and continuing local government areas listed in schedule 1A of that Act.

See the notice published in the gazette on 23 November 2007 at page 1680.

12 Vehicle used solely for carrying on business of well boring

A vehicle—

- (a) permanently fitted with well boring equipment; and
- (b) used on a road solely for carrying on the vehicle's registered operator's business of well boring.

**Schedule 3B Areas for schedule 3A, section
11 for category 1 vehicles
used solely to carry on
business of prospecting**

schedule 3A, section 11

Aramac Shire

Aurukun Shire

Baloone Shire

Barcaldine Shire

Barcoo Shire

Bauhinia Shire

Belyando Shire

Bendemere Shire

Blackall Shire

Booringa Shire

Boulia Shire

Bulloo Shire

Bungil Shire

Burke Shire

Carpentaria Shire

Cloncurry Shire

Cook Shire

Croydon Shire

Diamantina Shire

Doomadgee Shire

Emerald Shire other than within a 20km radius of the post office at Emerald

Schedule 3B

Etheridge Shire

Flinders Shire

Hope Vale Shire

Ilfracombe Shire

Injinoo Shire

Isisford Shire

Jericho Shire

Lockhart River Shire

Longreach Shire

Mapoon Shire

McKinlay Shire

Mornington Shire

City of Mount Isa other than within a 20km radius of the post office in the City

Murweh Shire

Napranum Shire

New Mapoon Shire

Paroo Shire

Peak Downs Shire

Quilpie Shire

Richmond Shire

Tambo Shire

Torres Shire

Umagico Shire

Warroo Shire

Winton Shire

Wujal Wujal Shire

Schedule 4 Dictionary

section 3

address means place of residence or business or, for a corporation, its registered office or place of business.

administrative fee for late payment means an administrative fee for late payment under schedule 3.

agricultural implement means a vehicle without its own automotive power, built to perform agricultural tasks.

Examples—

augers, conveyors, empty field bins, irrigating equipment and machinery fully carried on the three-point linkage of a tractor

agricultural machine means a machine with its own automotive power—

- (a) built to perform agricultural tasks; and
- (b) being used for agricultural purposes.

Examples—

tractors and harvesters being used for agricultural purposes

allowable modification, for a learner approved motorbike, means—

- (a) a modification that is—
 - (i) designed to enable a person with a physical impairment to ride the motorbike, other than a modification that increases the maximum engine power of the motorbike; and
 - (ii) approved under the Vehicle Standards and Safety Regulation; or

Example—

modification of the motorbike's foot controls to enable the driver to operate the motorbike by hand controls

- (b) a modification to the seating capacity approved under the Vehicle Standards and Safety Regulation.

ambulance vehicle means a motor vehicle used solely for rendering emergency treatment and pre-hospital patient care to, and the transport of, sick or injured persons by an ambulance service or hospital.

approved written-off vehicle examiner means a person approved by the chief executive to perform written-off vehicle inspections.

approved written-off vehicle nominee means a person approved by the chief executive to supervise the day to day running of written-off vehicle inspections for an entity

articulated bus means a bus with 2 or more rigid sections connected to one another in a way allowing—

- (a) passenger access between the sections; and
- (b) rotary movement between the sections.

ATM (aggregate trailer mass), for a trailer—

- (a) means the maximum mass, specified by the manufacturer, for the loaded trailer; and
- (b) includes any mass imposed on the vehicle towing the trailer when they are on a horizontal surface.

auctioneer means a person who carries on a business that includes selling or attempting to sell or offering for sale or resale notifiable vehicles, or parts of notifiable vehicles having a chassis number or VIN, by auction.

Australian Design Rule means a national standard under the *Motor Vehicle Standards Act 1989* (Cwlth), part 2.

auto parts dismantler means a person who carries on the business of—

- (a) demolishing or dismantling vehicles or vehicle parts or accessories; or
- (b) buying vehicles and substantially demolished or substantially dismantled vehicles and selling substantially demolished or substantially dismantled vehicles, whether or not the person also sells vehicle parts or accessories.

axle means 1 or more shafts positioned in a line across a vehicle, on which 1 or more wheels intended to support the vehicle, turn.

axle group means a single axle group, tandem axle group, twinsteer axle group, tri-axle group, quad-axle group or multi-axle group.

B-double means a combination consisting of a prime mover towing 2 semitrailers, with the first semitrailer being attached directly to the prime mover, and the second semitrailer being mounted on the rear of the first semitrailer.

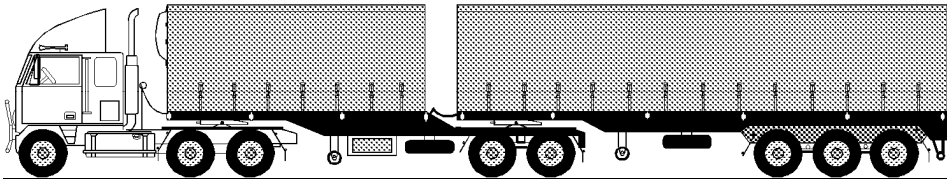

Typical B-double

B-double lead trailer means a semitrailer that is nominated for use as the lead trailer in a B-double.

B-triple means a combination consisting of a prime mover towing 3 semitrailers.

B-triple lead trailer means a semitrailer that is nominated for use as the lead trailer in a B-triple.

B-triple middle trailer means a semitrailer that is nominated for use as the second trailer in a B-triple.

bus means a motor vehicle built mainly to carry 10 or more seated adults, including the driver.

bus type 1 means a rigid bus with 2 axles and an MRC of not more than 12t.

bus type 2 means a rigid bus with—

- (a) 2 axles and an MRC of more than 12t; or
- (b) 3 or more axles.

caravan means an enclosed trailer designed for people to live in.

card holder means a person who holds—

- (a) a pensioner concession card; or
- (b) a seniors card.

category 1 vehicle means a vehicle with a GVM, GCM or ATM of not more than 4.5t.

category 2 vehicle means a vehicle with a GVM, GCM or ATM of more than 4.5t.

chassis number, of a vehicle, means an identification number of the chassis that is permanently marked on the chassis or another part of the vehicle, but does not include the vehicle's VIN.

client user, for part 8, division 5, see section 67.

community service organisation means an organisation established for the purpose of providing any of the following to persons in distress—

- (a) care, relief or support;
- (b) housing;
- (c) education or instruction, whether mental, physical, technical, social, spiritual or otherwise;
- (d) any other help.

concessional registration, for a vehicle, means concessional registration granted under part 9, division 3 or 4 for the registration of the vehicle.

conditionally registered means registered under section 10A(2).

conditionally registered vehicle means a vehicle registered under section 10A(2).

conditional registration see section 10A(2).

converter dolly means a trailer with a fifth wheel coupling designed to support a semitrailer for hauling purposes.

CTP insurance premium means the insurance premium payable under the *Motor Accident Insurance Act 1994* for an insurance certificate under that Act.

customised number plate means a number plate customised under section 30.

damaged includes significantly deteriorated.

dealer means—

- (a) the holder of a motor dealer's licence under the *Property Agents and Motor Dealers Act 2000* or, other than in section 61, the holder of an equivalent licence or other authority under a corresponding law; or
- (b) a person whose business is the sale of new motor vehicles or new or used trailers.

dealer plate means a number plate included in a series of number plates designated by the chief executive as dealer plates.

dog trailer means a trailer with—

- (a) 1 axle group or a single axle at the front that is connected to the towing vehicle by a drawbar; and
- (b) 1 axle group or single axle at the rear.

drawbar means a part of a trailer, other than a semitrailer, that connects the trailer body to a coupling for towing purposes.

drawn plant means a machine built on a trailer base, other than an agricultural implement.

eligible person, for part 8, division 5, see section 67.

engine capacity, for a motorbike, means the engine capacity—

- (a) under the manufacturer's specifications for the motorbike; or
- (b) stated in a LAM test report for the motorbike.

equipment trailer means a trailer that is a special purpose vehicle built to transport machinery forming an integral part of the trailer.

exempt vehicle see section 4.

fifth wheel coupling means a device, other than the upper rotating element and the kingpin (which are parts of a

semitrailer), used with a prime mover, semitrailer or a converter dolly to permit quick coupling and uncoupling and to provide for articulation.

fire and rescue appliance means a vehicle—

- (a) built or modified for—
 - (i) fighting fires; or
 - (ii) supporting or performing rescue operations; and
- (b) approved by the chief executive under the *Fire and Rescue Service Act 1990* as a suitably built or modified vehicle; and
- (c) operated by authorised fire officers under the *Fire and Rescue Service Act 1990*.

freestyle motocross means a competition to compare competitors' skills, or an event to demonstrate a rider's skills, in performing motorbike acrobatics on a motorbike that has been ridden off a ramp.

freestyle motocross area means an area not dedicated to public use as a road, from which other traffic is excluded while it is being used to perform the riding involved in freestyle motocross.

garage address of a vehicle, means the principal depot or base of operations of the vehicle.

gas certificate, for a gas system in a vehicle, means—

- (a) for a new vehicle—the certificate or plate for the system required under the *Petroleum and Gas (Production and Safety) Regulation 2004*, chapter 5, part 3 before the vehicle may be offered for sale; or

Editor's note—

See the *Petroleum and Gas (Production and Safety) Regulation 2004*, sections 98 and 105C.

- (b) for a used vehicle—the certificate for the system required under the *Petroleum and Gas (Production and Safety) Regulation 2004*, chapter 5, part 3 to be given, upon a sale or transfer of the vehicle, to the person to whom the vehicle is sold or transferred.

Editor's note—

See the *Petroleum and Gas (Production and Safety) Regulation 2004*, sections 99 and 105D.

gas system see the *Petroleum and Gas (Production and Safety) Act 2004*, schedule 2.

GCM (gross combination mass), of a motor vehicle, means the maximum loaded mass for the motor vehicle and any vehicles it may lawfully tow—

- (a) stated by the vehicle's manufacturer—
 - (i) on the vehicle's compliance plate; or
 - (ii) if there is no compliance plate—in another place;
or
- (b) stated by the chief executive or the corresponding authority under a corresponding law to the Act, if—
 - (i) the vehicle's manufacturer has not stated the vehicle's maximum loaded mass; or
 - (ii) the manufacturer cannot be identified; or
 - (iii) the vehicle has been modified and the maximum loaded mass stated by the manufacturer is no longer appropriate; or
- (c) stated in an evaluation report about the vehicle given by an accredited person.

give, in relation to information, for part 8, division 5, see section 67.

GTMR (gross trailer mass rating), of a trailer, means the mass transmitted to the ground by the axles of the trailer when—

- (a) coupled to a towing vehicle; and
- (b) carrying its maximum load approximately uniformly distributed over the trailer's load bearing area.

historic ambulance vehicle means a vehicle that was used as an ambulance vehicle but is now used for display by an ambulance service or historical ambulance society.

historic firefighting equipment means a vehicle that was used for firefighting but is now used for display by an historical fire brigade society.

history certificate see section 67A.

identifying number means—

- (a) a chassis number; or
- (b) an engine number; or
- (c) a VIN.

insolvency entity, for part 8, division 5, see section 67.

insurer means a body corporate authorised under the *Insurance Act 1973* (Cwlth) to carry on insurance business.

interstate register, for part 8, division 5, see section 67.

involved person, for part 8, division 5, see section 67.

LAM information, for part 3, division 3A, see section 21B.

LAM test report see section 21C.

late-model vehicle means a vehicle that is not more than 15 years old, counting from its date of manufacture.

lead trailer, in a combination, means the trailer that is, or that is to be, attached to the prime mover.

learner approved motorbike means a production motorbike—

- (a) that—
 - (i) is fitted with an electric motor; or
 - (ii) has an internal combustion engine with an engine capacity of not more than 660mL; and
- (b) with a power to weight ratio of not more than 150kW per tonne; and
- (c) that has not been modified other than for an allowable modification; and
- (d) that is stated to be a learner approved motorbike in a list kept by the chief executive and published on the department's website.

Editor's note—

At the commencement of this definition, the department's website was at <www.transport.qld.gov.au>.

limited access registration, for a conditionally registered vehicle, means registration that results in the vehicle being subject to conditions for use, stated in the safe movement guideline, that allow the vehicle to be used only in a stated area or only for a stated purpose.

litigation, for part 8, division 5, see section 67.

load, of a vehicle, includes—

- (a) anything normally taken from the vehicle when it is not in use; and
- (b) anything that may fall from the vehicle when it is in motion.

loaded mass, of a vehicle, means the vehicle's mass together with the mass of the vehicle's load transmitted to the ground.

long combination truck means a truck nominated to tow 2 or more trailers.

loss adjuster means a person who assesses the extent of loss or damage involving a vehicle for or on behalf of another person.

lowest premium set by any CTP insurer means the lowest CTP insurance premium set by any licensed insurer under the *Motor Accident Insurance Act 1994*, section 13A for the class of CTP insurance that relates to the vehicle for which an application for renewal of registration has been made.

low loader means a gooseneck semitrailer with a loading deck 1m or less above the ground.

low loader dolly means a mass distributing device that—

- (a) is of the type usually coupled between a prime mover and a low loader; and
- (b) consists of a gooseneck rigid frame; and
- (c) does not carry any load directly on itself; and

Schedule 4

- (d) is equipped with 1 or more axles, a kingpin and a fifth wheel coupling.

low powered motor vehicle means a motor vehicle propelled by—

- (a) a motor with a maximum power output of not more than 200 watts; or
- (b) 2 or more motors with a combined maximum power output of not more than 200 watts.

maximum engine power, for a motorbike, means the maximum engine power—

- (a) under the manufacturer's specifications for the motorbike; or
- (b) stated in a LAM test report for the motorbike.

medium combination truck means a truck, other than a short combination truck, nominated to haul 1 trailer.

minimum available registration term, for a vehicle, means—

- (a) if the vehicle is a category 2 vehicle—3 months; or
- (b) otherwise—6 months.

mobile machinery means a motor vehicle that—

- (a) is built to transport and operate machinery or equipment forming an integral part of the vehicle; and
- (b) is not—
 - (i) a truck, semitrailer or prime mover; or
 - (ii) a tow truck; or
 - (iii) a vehicle that may be conditionally registered.

motorised caravan means a motor vehicle designed mainly for people to live in.

motorised golf buggy means a motor vehicle that—

- (a) is designed as transport for persons playing, or persons associated with persons playing, golf; and
- (b) can not be driven faster than 10km/h.

motorised wheelchair means a motor vehicle that—

- (a) is designed and constructed for use by a seated person with mobility difficulties; and
- (b) is not capable of going faster than 10km/h; and
- (c) has a tare of not more than 110kgs.

motor race means a race involving motor vehicles, or a practice or a time trial for a race or competition involving 1 or more motor vehicles.

MRC (mass rating for charging), of a vehicle, means the maximum permissible mass of the vehicle and its load—

- (a) shown on the vehicle's compliance plate as the GVM, GTMR or ATM of the vehicle; or
- (b) for a vehicle without a compliance plate—decided by the chief executive or the corresponding authority under a corresponding law to the Act, having regard to the design and construction of—
 - (i) the vehicle; or
 - (ii) any of its components.

multi-axle group means—

- (a) for a dog trailer, 5 or more axles at the front or at the rear, or 5 or more axles at the front and 5 or more axles at the rear; or
- (b) for a pig trailer, 5 or more axles near the middle of the load carrying surface of the trailer; or
- (c) for a semitrailer, 5 or more axles towards the rear of the trailer; or
- (d) for a B-double lead trailer or B-triple lead trailer or B-triple middle trailer, 5 or more axles towards the rear of the trailer; or
- (e) for a converter dolly or low loader dolly, 5 or more axles located under the fifth wheel coupling.

multi-combination prime mover means a prime mover nominated to haul 2 or more trailers.

NEVDIS, for part 8, division 5, see section 67.

nominated, in relation to a vehicle, means nominated in an application for registration of the vehicle.

nominated configuration, for a category 2 vehicle, means the configuration in which the vehicle is nominated to operate for the term of its registration.

notifiable information, for a written-off vehicle, means—

- (a) the vehicle's chassis number or VIN; and
- (b) the vehicle's engine number, if available; and
- (c) if the vehicle has been assessed as a total loss—when the vehicle was assessed to be a total loss; and
- (d) whether the vehicle is a repairable write-off or a statutory write-off; and
- (e) the type, location and severity of the damage to the vehicle; and
- (f) details of the person providing the information mentioned in paragraphs (a) to (e).

notifiable vehicle means—

- (a) a vehicle that—
 - (i) is a late-model vehicle of 1 of the following types—
 - (A) a motor vehicle with a GVM not over 4.5t;
 - (B) a motorbike;
 - (C) a caravan;
 - (D) a trailer with an ATM over 4.5t; and
 - (ii) complies with the requirements of all Australian Design Rules applying to it; or
- (b) any other vehicle of a type notified by the chief executive by gazette notice.

notifier means any of the following—

- (a) an insurer;

- (b) a self-insurer;
- (c) a loss adjuster;
- (d) a dealer;
- (e) an auctioneer;
- (f) an auto parts dismantler.

observed trial means a competition to compare competitors' skills, or an event to demonstrate a rider's skills, in riding a motorbike around a marked course, 1 at a time.

observed trial area means an area not dedicated to public use as a road, from which other traffic is excluded while it is being used as a course for an observed trial.

passengers, of a vehicle, does not include the driver or a trainee driver of the vehicle or a person in the vehicle who is necessary for the normal operation of the vehicle.

pensioner concession card means a card known as a pensioner concession card issued under a Commonwealth law.

personal information, for part 8, division 5, see section 67.

personalised number plate means a number plate issued under section 27 as a personalised number plate.

pig trailer means a trailer with 1 axle group or a single axle near the middle of its load carrying surface, and connected to the towing vehicle by a drawbar.

plant means a machine with its own automotive power.

pole-type trailer means a trailer that—

- (a) is attached to a towing vehicle by a pole, or an attachment fitted to the pole; and
- (b) is ordinarily used for transporting loads, such as logs, pipes, structural members, or other long objects, that are generally capable of supporting themselves like beams between supports.

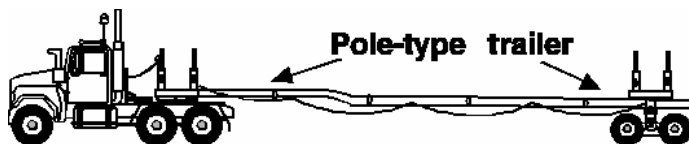

power to weight ratio, for a learner approved motorbike, is a ratio—

- (a) expressed in kilowatts per tonne; and
- (b) calculated by—
 - (i) dividing the maximum engine power by the sum of the tare mass and 90kg; and
 - (ii) multiplying the product of the division by 1000.

Example—

The power to weight ratio of a motorbike that has a maximum engine power of 54kW and a tare mass of 360kg is calculated by dividing 54kW by the sum of 360kg and 90kg (that is, 450kg) and multiplying the product of the division by 1000. In this example the power to weight ratio is 120kW/t.

prescribed concession information, about a person, means information from a State or Commonwealth government agency that shows a change in the person's benefits granted by the State or Commonwealth.

primary produce means—

- (a) tobacco; or
- (b) raw material for clothing or food derived from—
 - (i) agriculture; or
 - (ii) dairying; or
 - (iii) fishing; or
 - (iv) the raising of livestock; or
 - (v) viticulture.

primary producer means a person engaged mainly in the production of primary produce.

primary production vehicle means a vehicle that is—

- (a) owned by a person who is a primary producer; and

-
- (b) used only for carrying on the person's business as a primary producer; and
 - (c) either of the following—
 - (i) a prime mover or truck with a GVM of 6t or over 6t;
 - (ii) a trailer with an MRC of over 4.5t.

prime mover means a motor vehicle designed to tow a semitrailer.

production motorbike means a motorbike that—

- (a) is manufactured and marketed in volume for normal road use; and
- (b) conforms with the requirements applying to the motorbike under each vehicle law.

public access provider, for part 8, division 5, see section 67.

quad-axle group means a group of 4 axles, in which the horizontal distance between the centre-lines of the outermost axles is more than 3.2 metres but not more than 4.9 metres.

quad bike means a 4 wheeled motor vehicle that is ridden in the same way as a 2 wheeled motor vehicle.

racing track means a circuit or track, not dedicated to public use as a road, being used as a course for a motor race or motor race driver training, if other traffic is excluded from the circuit or track during its use for the race or training.

racing vehicle means a vehicle that is used in a motor race or for motor race driver training.

recklessly includes with gross negligence.

register, as a noun, see section 15.

registered operator, of a vehicle or dealer plate, see section 4A.

registration certificate, for a vehicle, means a certificate issued by the chief executive and including the matters about the vehicle listed in section 16(2).

registration label, for a vehicle, means a label issued by the chief executive and including the matters about the vehicle listed in section 32(2).

registration number means a distinguishing number—

- (a) assigned by the chief executive to identify a vehicle that is, or has been, registered; and
- (b) displayed, or intended for display, on a number plate.

registration-related amount, for a renewal of registration, means the total of the following fees payable under section 37(1)—

- (a) any relevant registration fee;
- (b) any registration administration fee for a conditionally registered vehicle;
- (c) any category 1 vehicle traffic improvement fee;
- (d) any category 2 registration administration fee;
- (e) any CTP insurance premium.

related area, for a racing track, means an area—

- (a) adjacent to the racing track where a racing vehicle is parked or driven for a purpose associated with the motor race or motor race driver training; and
- (b) not dedicated to public use as a road.

renewal notice see section 36.

repairable write-off—

- (a) means a notifiable vehicle that is a total loss but is not a statutory write-off; and
- (b) in the context of a written-off vehicle inspection and a written-off vehicle inspection report, includes a vehicle with a chassis number or VIN that is the same as the chassis number or VIN of a vehicle recorded in the register, or in a register kept under a corresponding law to this regulation, as a repairable write-off.

road related area means an area that is part of a road and—

- (a) divides a part of the road from another part of the road and is formed by lines marked on the road or is constructed on the road; or
- (b) is a footpath or nature strip; or
- (c) is open to the public and is designed for use by cyclists or animals.

Example for paragraph (a)—

traffic island

Road Use Management Regulation means the *Transport Operations (Road Use Management—Mass, Dimensions and Loading) Regulation 2005*.

safe movement guideline see section 10A(1)(a).

safety recall agency, for part 8, division 5, see section 67.

sale, of a vehicle, includes—

- (a) the hiring of the vehicle on hire-purchase; and
- (b) the leasing of the vehicle.

self-insurer means an entity that owns 5 or more notifiable vehicles for which there is no insurance policy with an insurer covering loss or damage.

semitrailer means a trailer (including a pole type trailer) that has—

- (a) 1 axle group or a single axle towards the rear; and
- (b) a means of attachment to a prime mover or a converter dolly that results in some of the load being imposed on the prime mover, or the converter dolly, as the case may be.

seniors card means a Queensland Government seniors card.

short combination prime mover means a prime mover nominated to tow 1 semitrailer.

short combination truck means a truck nominated to haul 1 trailer, if the combination has—

Schedule 4

- (a) 6 or fewer axles; and
- (b) a total mass of not more than 42.5t.

single axle means an axle not forming part of an axle group.

single axle group means a group of 2 or more axles, in which the horizontal distance between the centre-lines of the outermost axles is less than 1 metre.

special interest vehicle means—

- (a) a vehicle that is at least 30 years old; or
- (b) an historic ambulance vehicle or historic firefighting equipment; or
- (c) a street rod vehicle.

special plate means—

- (a) a customised number plate; or
- (b) a personalised number plate.

special purpose vehicle means—

- (a) a forklift, straddle carrier, mobile cherry picker or mobile crane, other than a vehicle that may be conditionally registered; or
- (b) a vehicle, other than a vehicle mentioned in paragraph (a) or a caravan, motorised caravan, mobile library, mobile workshop, mobile laboratory or mobile billboard, that has been built, or permanently modified, for a purpose other than for carrying goods or passengers.

special purpose vehicle (type o) means a special purpose vehicle, other than a special purpose vehicle (type p), that—

- (a) is built, or permanently modified, primarily for use on roads; and
- (b) has at least 1 axle or axle group loaded above the mass limits stated in the Road Use Management Regulation, schedule 2.

special purpose vehicle (type p) means a special purpose vehicle, other than a vehicle that may be conditionally registered, built or permanently modified for—

- (a) off-road use; or
- (b) use on a road related area; or
- (c) use on an area of road that is under construction.

special purpose vehicle (type t) means a special purpose vehicle, other than a special purpose vehicle (type p), that—

- (a) is built, or permanently modified, primarily for use on roads; and
- (b) has no axle or axle group loaded above the mass limits stated in the Road Use Management Regulation, schedule 2.

Examples of special purpose vehicle (type t)—

boring plant, fire-engine, mobile crane and truck mounted concrete pump

status certificate see section 67B.

statutory entity, for part 8, division 5, see section 67.

statutory write-off means a notifiable vehicle that is a total loss and that is—

- (a) a motor vehicle or trailer, other than a motorbike, that has been immersed—
 - (i) in salt water above the doorsill level for any period; or
 - (ii) in fresh water up to the dashboard or steering wheel for more than 48 hours; or
- (b) a motor bike that has been fully immersed—
 - (i) in salt water for any period; or
 - (ii) in fresh water for more than 48 hours; or
- (c) a motor vehicle or trailer that has been burnt to the extent that it is fit only for wrecking or scrap; or

Schedule 4

- (d) a motor vehicle or trailer that has been stripped of all, or a combination or most, interior and exterior body parts, panels and components; or

Examples of body parts, panels and components—

engine, wheels, bonnet, guards, doors, boot lid

- (e) a motor vehicle, other than a motorbike, that has been damaged to the extent of at least 3 of the following impact damage indicators—

(i) damage to an area of the roof equal to or exceeding 300mm by 300mm;

(ii) damage to an area of the cabin floor pan equal to or exceeding 300mm by 300mm;

(iii) damage to an area of the firewall equal to or exceeding 300mm by 300mm;

(iv) damage to the suspension;

(v) damage in the form of cracks or breaks to major mechanical components; or

Examples of major mechanical components—

engineblock, transmission casings

- (f) a motorbike that has—

(i) impact damage, other than scratching, to the suspension; and

(ii) at least 2 areas of structural frame damage.

street rod vehicle means a motor vehicle modified for safe road use that—

(a) has a body and frame built before 1949; or

(b) is a replica of a motor vehicle the body and frame of which were built before 1949.

tandem axle group means a group of at least 2 axles, in which the horizontal distance between the centre-lines of the outermost axles is at least 1 metre but not more than 2 metres.

tare, of a vehicle, means the total of the following—

(a) the mass of the vehicle when unloaded;

- (b) the mass of the fuel, water, lubricants and tools, and of any equipment and accessories, loaded on the vehicle and necessary for its normal operation.

tare mass, for a motorbike, means the mass of the motorbike—

- (a) with all fluid reservoirs on the motorbike, other than the fuel tank, filled to a normal operating level; and
- (b) with the fuel tank empty; and
- (c) with all standard equipment and any optional items of equipment fitted; and
- (d) without the weight of a motorbike rider or a passenger.

total loss means a notifiable vehicle damaged by accident, collision, demolition, dismantling, fire, flood, trespass or other event to the extent that its fair salvage value, when added to the cost of repairing it for use on a road or road related area, would be more than its fair market value immediately before the event that caused the damage.

tow truck means a motor vehicle equipped with a lifting or loading device capable of being used for the towing of a motor vehicle.

tractor means a motor vehicle used for towing purposes, other than a motor vehicle—

- (a) designed to carry passengers or goods (other than its own fuel or water); or
- (b) that is a tow truck.

Transport concession policy means the manual of policies and procedures issued by the chief executive for administering the scheme of vehicle registration established under this regulation.

tri-axle group means a group of at least 3 axles, in which the horizontal distance between the centre-lines of the outermost axles is more than 2 metres but not more than 3.2 metres.

truck means a rigid motor vehicle built mainly as a load carrying vehicle.

truck (type 1) means a truck with—

- (a) 2 axles and an MRC of not more than 12t; or
- (b) 3 axles and an MRC of not more than 16.5t; or
- (c) 4 or more axles and an MRC of not more than 20t.

truck (type 2) means a truck with—

- (a) 2 axles and an MRC of more than 12t; or
- (b) 3 axles and an MRC of more than 16.5t; or
- (c) 4 or more axles and an MRC of more than 20t.

twinsteer axle group means a group of 2 axles—

- (a) with single tyres; and
- (b) fitted to a motor vehicle; and
- (c) connected to the same steering mechanism; and
- (d) the horizontal distance between the centre-lines of which is at least 1 metre, but not more than 2 metres.

unrestricted access registration, for a conditionally registered vehicle, means registration that is not limited access registration or zone access registration.

use, of a vehicle on a road, includes standing the vehicle on the road.

vehicle law means—

- (a) the Road Use Management Regulation; or
- (b) the Vehicle Standards and Safety Regulation, to the extent the regulation requires compliance with the vehicle standards mentioned in the regulation.

vehicle related information, for part 8, division 5, see section 67.

vehicle related information provider, for part 8, division 5, see section 68A(1).

Vehicle Standards and Safety Regulation means the *Transport Operations (Road Use Management—Vehicle Standards and Safety) Regulation 1999*.

VIN, of a vehicle, means the unique vehicle identification number assigned to the vehicle.

walking speed equipment means a motor vehicle—

- (a) used for construction, maintenance or warehouse operation; and
- (b) designed mainly for use outside the road system; and
- (c) not capable of going faster than 10km/h.

written-off vehicle means a vehicle that is—

- (a) a repairable write-off; or
- (b) a statutory write-off.

written-off vehicle inspection means an inspection of a repairable write-off, in accordance with procedures approved by the chief executive, to decide on the vehicle's identity.

written-off vehicle inspection report means a report of a written-off vehicle inspection that includes a decision of an approved written-off vehicle examiner that the vehicle's identity is legitimate.

written-off vehicle inspection site means a place where written-off vehicle inspections are performed.

zone access registration, for a conditionally registered vehicle, means registration that results in the vehicle being subject to conditions for use, stated in the safe movement guideline, that limit the distance, for each stated zone, that a vehicle may travel on a single journey in the zone.

Endnotes

1 Index to endnotes

	Page
2 Date to which amendments incorporated	156
3 Key	157
4 Table of reprints	157
5 List of legislation	158
6 List of annotations	162

2 Date to which amendments incorporated

This is the reprint date mentioned in the Reprints Act 1992, section 5(c). Accordingly, this reprint includes all amendments that commenced operation on or before 1 July 2009. Future amendments of the Transport Operations (Road Use Management—Vehicle Registration) Regulation 1999 may be made in accordance with this reprint under the Reprints Act 1992, section 49.

3 Key

Key to abbreviations in list of legislation and annotations

Key	Explanation	Key	Explanation
AIA	= Acts Interpretation Act 1954	(prev)	= previously
amd	= amended	proc	= proclamation
amdt	= amendment	prov	= provision
ch	= chapter	pt	= part
def	= definition	pubd	= published
div	= division	R[X]	= Reprint No. [X]
exp	= expires/expired	RA	= Reprints Act 1992
gaz	= gazette	reloc	= relocated
hdg	= heading	renum	= renumbered
ins	= inserted	rep	= repealed
lap	= lapsed	(retro)	= retrospectively
notfd	= notified	rv	= revised edition
num	= numbered	s	= section
o in c	= order in council	sch	= schedule
om	= omitted	sdiv	= subdivision
orig	= original	SIA	= Statutory Instruments Act 1992
p	= page	SIR	= Statutory Instruments Regulation 2002
para	= paragraph	SL	= subordinate legislation
prec	= preceding	sub	= substituted
pres	= present	unnum	= unnumbered
prev	= previous		

4 Table of reprints

Reprints are issued for both future and past effective dates. For the most up-to-date table of reprints, see the reprint with the latest effective date.

If a reprint number includes a letter of the alphabet, the reprint was released in unauthorised, electronic form only.

Reprint No.	Amendments to	Effective	Reprint date
1	none	1 October 1999	1 October 1999
1A	1999 SL No. 286	1 January 2000	17 January 2000
1B	2000 SL No. 90	1 July 2000	18 August 2000
1C	2000 SL No. 297	27 November 2000	6 December 2000
1D	2001 SL No. 28	6 April 2001	20 April 2001
1E	2001 SL No. 145	1 October 2001	5 October 2001
2	2001 SL No. 145	1 October 2001	2 November 2001
2A	2001 SL No. 248	7 December 2001	14 December 2001
2B	2001 SL No. 248	1 February 2002	1 February 2002

Reprint No.	Amendments included	Effective	Notes
2C	2002 SL No. 112	1 July 2002	
2D	2002 SL No. 199	19 August 2002	

Endnotes

Reprint No.	Amendments included	Effective	Notes
2E	2000 SL No. 185	1 September 2002	
2F	2002 SL No. 251	30 September 2002	
2G	2002 SL No. 366	1 February 2003	
2H	2003 SL No. 60	4 April 2003	
2I	2003 SL No. 60	1 May 2003	
2J	2003 SL No. 106	1 July 2003	R2J withdrawn, see R3
3	—	1 July 2003	
3A	2004 SL No. 54	1 July 2004	
3B	2004 SL No. 319	1 January 2005	
3C	2005 SL No. 131	24 June 2005	
3D	2005 SL No. 91	1 July 2005	
3E	2005 SL No. 188	1 September 2005	
3F	2005 SL No. 215	26 September 2005	
3G	2005 SL No. 297	17 December 2005	
3H	—	1 February 2006	provs exp 31 January 2006
3I	2006 SL No. 90	1 July 2006	R3I withdrawn, see R4
4	—	1 July 2006	
4A	2007 SL No. 83	1 July 2007	
4B	2007 SL No. 200	17 August 2007	
4C	2008 SL No. 58	15 March 2008	
4D	2008 SL No. 131	1 July 2008	R4D withdrawn, see R5
	2008 SL No. 132		
	2008 SL No. 209		
5	—	1 July 2008	
5A	2009 SL No. 56	15 May 2009	
5B	2009 SL No. 64	1 July 2009	
	2009 SL No. 65		
	2009 SL No. 66		

5 List of legislation

Transport Operations (Road Use Management—Vehicle Registration) Regulation 1999 SL No. 225

made by the Governor in Council on 30 September 1999

notfd gaz 1 October 1999 pp 468–9

ss 1–2 commenced on date of notification

pt 8 div 5, sch 3 pt 2 items 2–4 commenced 1 January 2000 (see s 2(2))

remaining provisions commenced 1 October 1999 (see s 2(1))

exp 1 September 2010 (see SIA s 54)

Note—The expiry date may have changed since this reprint was published. See the latest reprint of the SIR for any change.

amending legislation—

Road Transport Reform Regulation 1999 SL No. 286 ss 1, 2(2), 4 sch 2

notfd gaz 19 November 1999 pp 1149–52

ss 1–2 commenced on date of notification

remaining provisions commenced 1 December 1999 (see s 2(2))

Transport Operations (Road Use Management—Vehicle Registration) Amendment Regulation (No. 1) 2000 SL No. 90

notfd gaz 19 May 2000 pp 218–19

ss 1–2 commenced on date of notification

remaining provisions commenced 1 July 2000 (see s 2)

Transport Legislation Amendment Regulation (No. 4) 2000 SL No. 297 pts 1, 8 s 44 sch 2

notfd gaz 24 November 2000 pp 1188–9

ss 1–2 commenced on date of notification

remaining provisions commenced 27 November 2000 (see s 2)

Transport Legislation Amendment Regulation (No. 1) 2001 SL No. 28 pts 1, 5

notfd gaz 6 April 2001 pp 1452–3

commenced on date of notification

Transport Legislation Amendment Regulation (No. 2) 2001 SL No. 57 pts 1, 11

notfd gaz 25 May 2001 pp 334–6

ss 1–2 commenced on date of notification

remaining provisions commenced 1 July 2001 (see s 2)

Transport Operations (Road Use Management—Vehicle Registration) Amendment Regulation (No. 1) 2001 SL No. 145

notfd gaz 24 August 2001 pp 1526–9

ss 1–2 commenced on date of notification

remaining provisions commenced 1 October 2001 (see s 2)

Transport Operations (Road Use Management—Vehicle Registration) Amendment Regulation (No. 3) 2001 SL No. 248

notfd gaz 7 December 2001 pp 1270–1

ss 10, 11, 15(3) commenced 1 February 2002 (see s 2)

remaining provisions commenced on date of notification

Transport Legislation Amendment Regulation (No. 2) 2002 SL No. 112 pts 1, 14

notfd gaz 24 May 2002 pp 308–10

ss 1–2 commenced on date of notification

remaining provisions commenced 1 July 2002 (see s 2)

Transport Operations (Road Use Management—Vehicle Registration) Amendment Regulation (No. 1) 2002 SL No. 185

notfd gaz 26 July 2002 pp 1212–13

ss 1–2 commenced on date of notification

remaining provisions commenced 1 September 2002 (see s 2)

Endnotes

Transport Legislation Amendment Regulation (No. 3) 2002 SL No. 199 pts 1, 4

notfd gaz 16 August 2002 pp 1420–1
ss 1–2 commenced on date of notification
remaining provisions commenced 19 August 2002 (see s 2)

Transport Legislation Amendment Regulation (No. 4) 2002 SL No. 251 pts 1, 3, s 22 sch

notfd gaz 27 September 2002 pp 340–4
ss 1–2 commenced on date of notification
remaining provisions commenced 30 September 2002 (see s 2)

Transport Operations (Road Use Management—Vehicle Registration) Amendment Regulation (No. 2) 2002 SL No. 366

notfd gaz 20 December 2002 pp 1359–63
ss 1–2 commenced on date of notification
remaining provisions commenced 1 February 2003 (see s 2)

Transport Operations (Road Use Management—Vehicle Registration) Amendment Regulation (No. 1) 2003 SL No. 60 pts 1–2

notfd gaz 4 April 2003 pp 1198–9
ss 1–2, 20 commenced on date of notification
remaining provisions commenced 1 May 2003 (see s 2)

Transport Legislation Amendment Regulation (No. 2) 2003 SL No. 106 pts 1, 15

notfd gaz 30 May 2003 pp 371–6
ss 1–2 commenced on date of notification
remaining provisions commenced 1 July 2003 (see s 2)

Transport Legislation Amendment Regulation (No. 1) 2004 SL No. 54 pts 1, 14

notfd gaz 14 May 2004 pp 112–14
ss 1–2 commenced on date of notification
remaining provisions commenced 1 July 2004 (see s 2)

Local Government (Community Government Areas) Regulation 2004 SL No. 319 ss 1–2, 23 sch 1

notfd gaz 17 December 2004 pp 1277–85
ss 1–2 commenced on date of notification
remaining provisions commenced 1 January 2005 (see s 2)

Transport Legislation Amendment Regulation (No. 1) 2005 SL No. 91 pts 1, 15

notfd gaz 20 May 2005 pp 224–6
ss 1–2 commenced on date of notification
remaining provisions commenced 1 July 2005 (see s 2)

Transport Operations (Road Use Management—Vehicle Registration) Amendment Regulation (No. 1) 2005 SL No. 131

notfd gaz 24 June 2005 pp 639–45
commenced on date of notification

**Transport Operations (Road Use Management—Mass, Dimensions and Loading)
Regulation 2005 SL No. 188 ss 1–2, pt 9 div 5**

notfd gaz 12 August 2005 pp 1297–1303

ss 1–2 commenced on date of notification

remaining provisions commenced 1 September 2005 (see s 2)

**Transport Operations (Road Use Management—Vehicle Registration) Amendment
Regulation (No. 2) 2005 SL No. 215**

notfd gaz 2 September 2005 pp 71–2

ss 1–2 commenced on date of notification

remaining provisions commenced 26 September 2005 (see s 2)

Transport Legislation Amendment Regulation (No. 3) 2005 SL No. 297 pts 1, 3

notfd gaz 9 December 2005 pp 1375–8

ss 1–2 commenced on date of notification

remaining provisions commenced 17 December 2005 (see s 2)

**Transport Legislation and Another Regulation Amendment Regulation (No. 1) 2006
SL No. 90 ss 1, 2(1), pt 17**

notfd gaz 19 May 2006 pp 252–4

ss 1–2 commenced on date of notification

remaining provisions commenced 1 July 2006 (see s 2(1))

Transport Legislation (Fees) Amendment Regulation (No. 1) 2007 SL No. 83 pts 1, 16

notfd gaz 18 May 2007 pp 345–8

ss 1–2 commenced on date of notification

remaining provisions commenced 1 July 2007 (see s 2)

**Transport Operations (Passenger Transport) and Other Legislation Amendment
Regulation (No. 2) 2007 SL No. 200 ss 1, 17 sch**

notfd gaz 17 August 2007 pp 2023–5

commenced on date of notification

Transport Legislation Amendment Regulation (No. 1) 2008 SL No. 58 pts 1, 4

notfd gaz 14 March 2008 pp 1469–72

ss 1–2 commenced on date of notification

remaining provisions commenced 15 March 2008 (see s 2)

**Transport Legislation (Fees) Amendment Regulation (No. 1) 2008 SL No. 131 pts 1,
16**

notfd gaz 23 May 2008 pp 543–5

ss 1–2 commenced on date of notification

remaining provisions commenced 1 July 2008 (see s 2)

**Transport Operations (Road Use Management—Vehicle Registration) Amendment
Regulation (No. 1) 2008 SL No. 132**

notfd gaz 23 May 2008 pp 543–5

ss 1–2 commenced on date of notification

remaining provisions commenced 1 July 2008 (see s 2)

Endnotes

Public Service Regulation 2008 SL No. 209 ss 1–2, 20 sch 2

notfd gaz 27 June 2008 pp 1268–78

ss 1–2 commenced on date of notification

remaining provisions commenced 1 July 2008 (see s 2)

Transport Operations (Road Use Management—Vehicle Registration) and Another Regulation Amendment Regulation (No. 1) 2009 SL No. 56 pts 1–2, s 2 sch

notfd gaz 15 May 2009 pp 258–9

commenced on date of notification

Transport Legislation (Fees) Amendment Regulation (No. 1) 2009 SL No. 64 pts 1, 16

notfd gaz 22 May 2009 pp 331–3

ss 1–2 commenced on date of notification

remaining provisions commenced 1 July 2009 (see s 2)

Transport Legislation Amendment Regulation (No. 1) 2009 SL No. 65 pts 1, 4

notfd gaz 22 May 2009 pp 331–3

ss 1–2 commenced on date of notification

s 25 commenced 1 July 2009 (amdt could not be given effect)

remaining provisions commenced 1 July 2009 (see s 2)

Transport Operations (Road Use Management—Vehicle Registration) Amendment Regulation (No. 1) 2009 SL No. 66

notfd gaz 22 May 2009 pp 331–3

ss 1–2 commenced on date of notification

remaining provisions commenced 1 July 2009 (see s 2)

Queensland Civil and Administrative Tribunal (Jurisdiction Provisions) Amendment Act 2009 No. 24 ss 1–2, ch 13 pt 20

date of assent 26 June 2009

ss 1–2 commenced on date of assent

remaining provisions not yet proclaimed into force (see s 2)

6 List of annotations

Meaning of “exempt vehicle”

s 4 amd 2000 SL No. 297 s 45; 2001 SL No. 248 s 4; 2003 SL No. 60 s 4

Meaning of “registered operator” in this regulation

s 4A ins 2000 SL No. 297 s 46

Persons eligible to register vehicle

s 7 amd 2003 SL No. 60 s 5

Compliance with vehicle law

s 8 amd 2003 SL No. 60 s 6

PART 3—VEHICLE REGISTRATION

Vehicles used on roads must be registered

s 10 amd 2001 SL No. 28 s 23

Division 2—Conditional registration**div hdg** sub 2003 SL No. 60 s 7**Conditional registration****s 10A** ins 2003 SL No. 60 s 7
amd 2005 SL No. 188 s 73**Division 3—Registration generally****div hdg** ins 2003 SL No. 60 s 7**Application for registration****s 11** amd 2000 SL No. 297 s 47; 2001 SL No. 28 s 24; 2002 SL No. 251 s 22 sch;
2003 SL No. 60 s 8, 2007 SL No. 200 s 17 sch**Driving or towing unregistered vehicle to place for inspection****prov hdg** amd 2002 SL No. 251 s 6(1)**s 12A** ins 2001 SL No. 28 s 25
amd 2002 SL No. 251 s 6(2)–(3); 2005 SL No. 131 s 3**Vehicle inspections****s 13** amd 1999 SL No. 286 s 4 sch 2; 2000 SL No. 297 s 44 sch 2
sub 2002 SL No. 251 s 7**Determination of applications****s 14** amd 2001 SL No. 28 s 26; 2002 SL No. 251 s 8**Registered vehicles register****s 15** amd 2000 SL No. 297 s 44 sch 2; 2002 SL No. 251 s 9; 2002 SL No. 366 s 4;
2003 SL No. 60 s 9; 2009 SL No. 65 s 22**Registration certificates****s 16** amd 2000 SL No. 297 s 44 sch 2; 2003 SL No. 60 s 10**Registered operator to notify change of particulars****prov hdg** amd 2000 SL No. 297 s 44 sch 2**s 17** amd 2000 SL No. 297 s 44 sch 2**Recording change in vehicle particulars and reassessment of registration fee****s 18** amd 2000 SL No. 297 s 44 sch 2; 2002 SL No. 251 s 10; 2007 SL No. 200 s 17
sch; 2009 SL No. 56 s 2 sch**Seasonal registration****s 20** amd 2000 SL No. 297 s 44 sch 2; 2001 SL No. 248 s 5**Division 3—Limited use registration****div hdg** om 2003 SL No. 60 s 11**Division 3A—Approval of motorbikes as learner approved motorbikes****div 3A (ss 21A–21D)** ins 2009 SL No. 65 s 23**Limited use registration****s 22** amd 2000 SL No. 90 s 4
om 2003 SL No. 60 s 11

Endnotes

Chief executive to assign registration number and issue number plates

s 23 amd 2000 SL No. 297 s 44 sch 2; 2003 SL No. 60 s 12; 2005 SL No. 131 s 4

Position, visibility and legibility of number plate

prov hdg sub 2000 SL No. 297 s 48(1)

s 24 amd 1999 SL No. 286 s 4 sch 2; 2000 SL No. 297 ss 48(2)–(4), 44 sch 2; 2003
 SL No. 60 s 13; 2005 SL No. 131 s 5

Time for attaching number plates

s 25 amd 2000 SL No. 297 s 44 sch 2

Personalised number plates

s 27 amd 2003 SL No. 60 s 14

Customised number plates

s 30 amd 2000 SL No. 297 s 44 sch 2

Accessory plates

s 31 amd 2003 SL No. 60 s 15

Accessory plate for tow truck

s 31A ins 2000 SL No. 297 s 49
 amd 2009 SL No. 56 s 2 sch

Chief executive to issue registration labels

s 32 amd 2000 SL No. 297 s 44 sch 2; 2003 SL No. 60 s 16; 2009 SL No. 65 s 24

Position for attaching registration label

s 33 amd 2000 SL No. 297 s 44 sch 2

Time for attaching registration label

s 34 amd 2000 SL No. 297 s 44 sch 2; 2005 SL No. 131 s 6

Division 6—Further obligations of registered operator

div hdg sub 2000 SL No. 297 s 44 sch 2
 om 2002 SL No. 251 s 11

Vehicle destroyed or written off

s 35 amd 2000 SL No. 297 s 44 sch 2
 om 2002 SL No. 251 s 11

Registration renewal notice

s 36 amd 2000 SL No. 297 s 44 sch 2

Renewal of registration

s 37 amd 2000 SL No. 297 s 44 sch 2; 2002 SL No. 366 s 5; 2003 SL No. 60 s 17;
 2005 SL No. 131 s 7

When surcharge is payable for renewal

s 37A ins 2002 SL No. 366 s 6
 amd 2003 SL No. 60 s 18

Registration term if overpayment or underpayment of registration-related amount and any surcharge

s 37B ins 2002 SL No. 366 s 6
amd 2003 SL No. 60 s 19

Administrative fee for late payment if cheque dishonoured

s 37C ins 2003 SL No. 60 s 20

Issue of receipt and updating of records

s 38 amd 2000 SL No. 297 s 44 sch 2; 2005 SL No. 131 s 8

Transfer of registration

s 39 amd 2000 SL No. 297 s 44 sch 2; 2002 SL No. 251 s 22 sch; 2007 SL No. 200 s 17 sch

Transfer of registration under legal process

s 41 amd 2000 SL No. 297 ss 50, 44 sch 2

Refusing to register transfer of registration

s 42 amd 2002 SL No. 251 s 22 sch; 2003 SL No. 60 s 21

Return of registration plates when registration expires

s 44 amd 2000 SL No. 297 s 44 sch 2

Cancellation of registration at registered operator's request

prov hdg amd 2000 SL No. 297 s 44 sch 2

s 45 amd 2000 SL No. 297 s 44 sch 2; 2002 SL No. 251 s 12; 2003 SL No. 60 s 22

Cancellation if registration in other State

s 45A ins 2001 SL No. 248 s 6

Partial refund of registration fee

s 46 amd 2000 SL No. 297 s 44 sch 2; 2001 SL No. 248 s 7

Cancellation for noncompliance with defect notice

s 47 amd 2000 SL No. 297 s 44 sch 2

Cancellation of registration of vehicle or dealer plate

s 48 amd 2000 SL No. 297 s 44 sch 2; 2001 SL No. 248 s 8; 2002 SL No. 251 s 13; 2005 SL No. 131 s 9

Recording cancellation of registration in register

s 49 amd 2000 SL No. 297 ss 51, 44 sch 2; 2001 SL No. 248 s 9; 2002 SL No. 251 s 14

Unregistered vehicle permits

s 50 amd 2000 SL No. 297 s 44 sch 2; 2003 SL No. 60 s 23

Registration of dealer plate

s 52 amd 2003 SL No. 60 s 24

Attaching dealer plate

s 53 amd 2000 SL No. 297 s 52

Endnotes

Use of dealer plates

s 54 amd 2003 SL No. 60 s 25

PART 7A—WRITTEN-OFF VEHICLES

pt hdg ins 2002 SL No. 251 s 15

Division 1—Objects of part 7A

div hdg ins 2002 SL No. 251 s 15
amd 2007 SL No. 200 s 17 sch

Objects

s 55A ins 2002 SL No. 251 s 15

Division 2—Notifying of written-off vehicle information

div 2 (ss 55B–55O) ins 2002 SL No. 251 s 15

Division 3—Written-off vehicle inspections

div hdg ins 2002 SL No. 251 s 15

Definition for div 3

s 55P ins 2002 SL No. 251 s 15

Approvals

s 55Q ins 2002 SL No. 251 s 15

Conditions of approval

s 55R ins 2002 SL No. 251 s 15

Refusing to grant approval

s 55S ins 2002 SL No. 251 s 15

Approval prescribed for the Act, ss 17B(2) and 18(1)(c)(ii)

prov hdg amd 2009 SL No. 56 s 2 sch

s 55T ins 2002 SL No. 251 s 15
amd 2009 SL No. 56 s 2 sch; 2009 SL No. 65 s 25 (amdt could not be given effect)

Division 4—Offences relating to written-off vehicle inspections

div 4 (ss 55U–55ZB) ins 2002 SL No. 251 s 15

Replacement registration items

s 56 amd 2000 SL No. 297 s 44 sch 2

Chief executive may require exchange of number plates

s 57 amd 2000 SL No. 297 s 44 sch 2

Chief executive may require return of number plates

s 58 amd 2000 SL No. 297 s 53

Permit to use intercepted unregistered vehicle on road

s 63 amd 1999 SL No. 286 s 4 sch 2; 2003 SL No. 60 s 26; 2005 SL No. 131 s 10

Damaged or dirty number plates

s 64 amd 2000 SL No. 297 s 44 sch 2

Decision to which this division applies

s 65 amd 2002 SL No. 251 s 16; 2009 SL No. 65 s 26

Review of decisions

s 66 amd 2002 SL No. 251 s 22 sch

Definitions for div 5

s 67 sub 2000 SL No. 297 s 54
 def “**eligible person**” amd 2005 SL No. 131 s 11
 def “**give**” ins 2005 SL No. 215 s 4(2)
 def “**history certificate**” ins 2005 SL No. 215 s 4(2)
 def “**insolvency entity**” amd 2003 SL No. 60 s 27
 def “**interstate register**” ins 2005 SL No. 215 s 4(2)
 def “**litigation**” amd 2003 SL No. 60 s 27
 def “**NEVDIS**” ins 2005 SL No. 215 s 4(2)
 def “**personal information**” ins 2001 SL No. 248 s 10
 def “**status certificate**” ins 2005 SL No. 215 s 4(2)
 def “**vehicle related information**” ins 2001 SL No. 248 s 10
 sub 2002 SL No. 251 s 17(1)–(2); 2005 SL No. 215 s 4(1)–(2)
 def “**vehicle related information provider**” ins 2001 SL No. 248 s 10
 sub 2005 SL No. 215 s 4(1)–(2)
 def “**written-off vehicle information**” ins 2002 SL No. 251 s 17(2)
 om 2005 SL No. 215 s 4(1)

Meaning of “history certificate”

s 67A ins 2005 SL No. 215 s 5
 amd 2005 SL No. 297 s 6

Meaning of “status certificate”

s 67B ins 2005 SL No. 215 s 5
 amd 2005 SL No. 297 s 7

Release of information on payment of fee

s 68 sub 2000 SL No. 297 s 54

Release of information to toll road operator, local government tollway operator and other persons

s 68AA ins 2009 SL No. 56 s 3

Release of vehicle related information

s 68A ins 2001 SL No. 248 s 11
 amd 2002 SL No. 251 s 18
 sub 2005 SL No. 215 s 6
 amd 2009 SL No. 56 s 4

Fee or amount payable to vehicle related information provider

s 68B ins 2005 SL No. 215 s 6

Fees

s 69 amd 2009 SL No. 56 s 5

Charging categories

s 70 amd 2000 SL No. 297 s 55; 2009 SL No. 66 s 4

Endnotes

Exemption from payment of fee

s 71 amd 2000 SL No. 297 s 44 sch 2; 2005 SL No. 131 s 12; 2008 SL No. 209 s 20 sch 2

Concessional registration fees—category 1 vehicles

s 72 amd 2000 SL No. 297 s 44 sch 2; 2003 SL No. 60 s 28

Concessional registration fees—primary production vehicles

prov hdg amd 2003 SL No. 60 s 29(1)

s 73 amd 2003 SL No. 60 s 29(2)–(3)

Concessional registration fee for motorised caravan for card holders

s 74 amd 2003 SL No. 60 s 30

Concessional registration fees for other vehicles

s 75 amd 2003 SL No. 60 s 31; 2006 SL No. 90 s 36

Offences involving registration certificates etc.

s 76 amd 2000 SL No. 297 s 56

PART 11—TRANSITIONAL PROVISIONS

pt hdg sub 2002 SL No. 251 s 19(1)

Division 1—Transitional provisions for Transport Operations (Road Use Management—Vehicle Registration) Regulation 1999

div hdg ins 2002 SL No. 251 s 19(2)

Division 2—Transitional provision for written-off vehicle amendments

div hdg ins 2002 SL No. 251 s 19(3)

Registration of vehicle recorded as a written-off vehicle under corresponding law

s 84 prev s 84 om R1 (see RA s 40)
pres s 84 ins 2002 SL No. 251 s 19(3)

PART 12—EXPIRY

pt hdg prev pt hdg om R1 (see RA s 7(1)(k))
pres pt hdg ins 2005 SL No. 215 s 7
exp 31 January 2006 (see s 85)

Expiry of provisions about particular fees and this part

s 85 prev s 85 om R1 (see RA s 40)
pres s 85 ins 2005 SL No. 215 s 7
exp 31 January 2006 (see s 85)

Amendment of sch 1, pt 45B

s 86 om R1 (see RA s 40)

Insertion of new sch 1, pt 45E

s 87 om R1 (see RA s 40)

PART 13—AMENDMENT OF TRAFFIC REGULATION 1962

pt 13 (ss 88–89) om R1 (see RA ss 7(1)(k) and 40)

PART 14—AMENDMENT OF TRANSPORT OPERATIONS (ROAD USE MANAGEMENT) REGULATION 1995

pt 14 (ss 90–99) om R1 (see RA ss 7(1)(k) and 40)

SCHEDULE 1—CATEGORY 1 VEHICLE REGISTRATION FEES

- sub 2000 SL No. 90 s 5
- amd 2000 SL No. 297 ss 57, 44 sch 2
- sub 2001 SL No. 57 s 22
- amd 2001 SL No. 248 s 12
- sub 2002 SL No. 112 s 28; 2002 SL No. 185 s 4
- amd 2003 SL No. 60 s 32
- sub 2003 SL No. 106 s 30; 2004 SL No. 54 s 28
- amd 2005 SL No. 131 s 13
- sub 2005 SL No. 91 s 30; 2006 SL No. 90 s 37; 2007 SL No. 83 s 32; 2008 SL No. 131 s 33; 2009 SL No. 64 s 33

SCHEDULE 2—CATEGORY 2 VEHICLE REGISTRATION FEES

- sub 2000 SL No. 90 s 5
- amd 2000 SL No. 297 s 58
- sub 2001 SL No. 57 s 22
- amd 2001 SL No. 145 s 4; 2001 SL No. 248 s 13
- sub 2002 SL No. 112 s 28
- amd 2002 SL No. 185 s 4; 2003 SL No. 60 s 33
- sub 2003 SL No. 106 s 30; 2004 SL No. 54 s 28; 2005 SL No. 91 s 30; 2006 SL No. 90 s 37; 2007 SL No. 83 s 32
- amd 2008 SL No. 131 s 34; 2008 SL No. 132 s 4; 2009 SL No. 64 s 34; 2009 SL No. 66 s 5

SCHEDULE 3—OTHER FEES

- sub 2000 SL No. 90 s 5; 2001 SL No. 57 s 22; 2001 SL No. 248 s 14; 2002 SL No. 112 s 28
- amd 2002 SL No. 199 s 9; 2002 SL No. 251 s 20; 2002 SL No. 366 s 7; 2003 SL No. 60 s 34
- sub 2003 SL No. 106 s 30; 2004 SL No. 54 s 28; 2005 SL No. 91 s 30
- amd 2005 SL No. 215 s 8
- pt 2, items 6 and 16 exp 31 January 2006 (see s 85)
- sub 2006 SL No. 90 s 37; 2007 SL No. 83 s 32; 2008 SL No. 131 s 35; 2009 SL No. 64 s 35

SCHEDULE 3A—VEHICLES FOR PARTICULAR CONCESSIONAL REGISTRATION FEES

- ins 2003 SL No. 60 s 35

Vehicle used only in particular areas

- s 4** amd 2004 SL No. 319 s 23 sch 1

Vehicle used solely for carrying on business of prospecting in particular areas

- s 11** amd 2008 SL No. 58 s 11

Endnotes

SCHEDULE 3B—AREAS FOR SCHEDULE 3A, SECTION 11 FOR CATEGORY 1 VEHICLES USED SOLELY TO CARRY ON BUSINESS OF PROSPECTING

ins 2003 SL No. 60 s 35
amd 2008 SL No. 58 s 12

SCHEDULE 4—DICTIONARY

def “**administrative fee for late payment**” ins 2002 SL No. 366 s 8
def “**agricultural implement**” amd 2005 SL No. 131 s 14(3)
def “**agricultural machine**” sub 2000 SL No. 297 s 59(1)–(2)
def “**allowable modification**” ins 2009 SL No. 65 s 27
def “**approved written-off vehicle examiner**” ins 2002 SL No. 251 s 21
def “**approved written-off vehicle nominee**” ins 2002 SL No. 251 s 21
def “**auctioneer**” ins 2002 SL No. 251 s 21
def “**Australian Design Rule**” ins 2002 SL No. 251 s 21
def “**auto parts dismantler**” ins 2002 SL No. 251 s 21
def “**axle**” sub 2000 SL No. 90 s 6(1)–(2)
def “**axle group**” ins 2009 SL No. 66 s 6(1)
def “**B-double lead trailer**” ins 2009 SL No. 66 s 6(1)
def “**B-triple**” ins 2009 SL No. 66 s 6(1)
def “**B-triple lead trailer**” ins 2009 SL No. 66 s 6(1)
def “**B-triple middle trailer**” ins 2009 SL No. 66 s 6(1)
def “**bus**” amd 2000 SL No. 297 s 59(3)
def “**bus type 2**” amd 2000 SL No. 90 s 6(3)
def “**category 1 vehicle**” amd 2009 SL No. 64 s 36(2)
def “**category 2 vehicle**” amd 2009 SL No. 64 s 36(2)
def “**chassis number**” ins 2002 SL No. 251 s 21
def “**community service organisation**” ins 2003 SL No. 60 s 36(2)
def “**concessional registration**” ins 2006 SL No. 90 s 38
def “**conditionally registered**” ins 2003 SL No. 60 s 36(2)
def “**conditionally registered vehicle**” ins 2003 SL No. 60 s 36(2)
def “**conditional registration**” ins 2003 SL No. 60 s 36(2)
def “**converter dolly**” ins 2009 SL No. 66 s 6(1)
def “**CTP insurance premium**” ins 2002 SL No. 366 s 8
def “**dealer**” amd 2000 SL No. 297 s 59(4); 2002 SL No. 251 s 22 sch
def “**Doc Base Manual**” om 2005 SL No. 131 s 14(1)
def “**dog trailer**” ins 2009 SL No. 66 s 6(1)
def “**drawbar**” ins 2009 SL No. 66 s 6(1)
def “**drawn plant**” ins 2000 SL No. 90 s 6(2)
def “**engine capacity**” ins 2009 SL No. 65 s 27
def “**fifth wheel coupling**” ins 2009 SL No. 66 s 6(1)
def “**fire and rescue appliance**” ins 2000 SL No. 297 s 59(2)
amd 2001 SL No. 248 s 15(4); 2002 SL No. 251 s 22 sch
def “**freestyle motocross**” ins 2003 SL No. 60 s 36(2)
def “**freestyle motocross area**” ins 2003 SL No. 60 s 36(2)
def “**gas certificate**” ins 2007 SL No. 200 s 17 sch
amd 2009 SL No. 56 s 2 sch
def “**gas system**” ins 2007 SL No. 200 s 17 sch
def “**give**” ins 2005 SL No. 215 s 9

- def **“history certificate”** ins 2005 SL No. 215 s 9
- def **“identifying number”** ins 2002 SL No. 251 s 21
- def **“insolvency entity”** ins 2001 SL No. 248 s 15(2)
- def **“insurer”** ins 2002 SL No. 251 s 21
- def **“interstate register”** ins 2005 SL No. 215 s 9
- def **“LAM information”** ins 2009 SL No. 65 s 27
- def **“LAM test report”** ins 2009 SL No. 65 s 27
- def **“late-model vehicle”** ins 2002 SL No. 251 s 21
- def **“lead trailer”** ins 2009 SL No. 66 s 6(1)
- def **“learner approved motorbike”** ins 2009 SL No. 65 s 27
- def **“limited access registration”** ins 2003 SL No. 60 s 36(2)
- def **“local agency”** om 2005 SL No. 131 s 14(1)
- def **“long combination prime mover”** ins 2000 SL No. 90 s 6(2)
om 2009 SL No. 64 s 36(1)
- def **“long combination prime mover (type 1)”** om 2000 SL No. 90 s 6(1)
- def **“long combination prime mover (type 2)”** om 2000 SL No. 90 s 6(1)
- def **“loss adjuster”** ins 2002 SL No. 251 s 21
- def **“lowest premium set by any CTP insurer”** ins 2002 SL No. 366 s 8
- def **“low loader”** ins 2000 SL No. 297 s 59(2)
- def **“low loader dolly”** ins 2000 SL No. 297 s 59(2)
- def **“maximum engine power”** ins 2009 SL No. 65 s 27
- def **“medium combination prime mover”** om 2009 SL No. 64 s 36(1)
- def **“medium combination truck”** sub 2000 SL No. 90 s 6(1)–(2)
- def **“minimum available registration term”** ins 2002 SL No. 366 s 8
- def **“mobile machinery”** amd 2003 SL No. 60 s 36(3)
- def **“motorcycle”** om 2000 SL No. 297 s 59(1)
- def **“motorised wheelchair”** amd 2005 SL No. 131 s 14(4)
- def **“motor race”** ins 2001 SL No. 248 s 15(2)
- def **“multi-axle group”** ins 2009 SL No. 66 s 6(1)
- def **“multi-combination prime mover”** ins 2008 SL No. 132 s 5
- def **“NEVDIS”** ins 2005 SL No. 215 s 9
- def **“notifiable information”** ins 2002 SL No. 251 s 21
- def **“notifiable vehicle”** ins 2002 SL No. 251 s 21
- def **“notifier”** ins 2002 SL No. 251 s 21
- def **“observed trial”** ins 2003 SL No. 60 s 36(2)
- def **“observed trial area”** ins 2003 SL No. 60 s 36(2)
- def **“passengers”** ins 2000 SL No. 90 s 6(2)
- def **“passenger vehicle”** om 2000 SL No. 297 s 59(1)
- def **“personal information”** ins 2001 SL No. 248 s 15(3)
- def **“pig trailer”** ins 2009 SL No. 66 s 6(1)
- def **“plant”** ins 2000 SL No. 90 s 6(2)
- def **“pole-type trailer”** amd 2000 SL No. 90 s 6(4)
- def **“power to weight ratio”** ins 2009 SL No. 65 s 27
- def **“prescribed concession information”** ins 2003 SL No. 60 s 36(2)
- def **“primary produce”** amd 2000 SL No. 297 s 59(5)
- def **“primary production vehicle”** sub 2001 SL No. 248 s 15(1)–(2)
- def **“production motorbike”** ins 2009 SL No. 65 s 27
- def **“quad-axle group”** ins 2009 SL No. 66 s 6(1)

Endnotes

- def “**quad bike**” ins 2003 SL No. 60 s 36(2)
- def “**racing track**” ins 2001 SL No. 248 s 15(2)
- def “**racing vehicle**” ins 2001 SL No. 248 s 15(2)
- def “**recklessly**” ins 2002 SL No. 251 s 21
- def “**registered operator**” ins 2000 SL No. 297 s 59(2)
- def “**registered owner**” om 2000 SL No. 297 s 59(1)
- def “**registration-related amount**” ins 2002 SL No. 366 s 8
sub 2003 SL No. 60 s 36(1)–(2)
- def “**related area**” ins 2001 SL No. 248 s 15(2)
- def “**repairable write-off**” ins 2002 SL No. 251 s 21
- def “**Road Use Management Regulation**” amd 2005 SL No. 188 s 74(1)
- def “**safe movement guideline**” ins 2003 SL No. 60 s 36(2)
- def “**self-insurer**” ins 2002 SL No. 251 s 21
- def “**semitrailer**” sub 2009 SL No. 66 s 6(2)
- def “**short combination truck**” sub 2000 SL No. 90 s 6(1)–(2)
- def “**single axle**” ins 2009 SL No. 66 s 6(1)
- def “**single axle group**” ins 2009 SL No. 66 s 6(1)
- def “**special purpose vehicle**” sub 2000 SL No. 90 s 6(1)–(2)
amd 2003 SL No. 60 s 36(4)
- def “**special purpose vehicle (type 1)**” om 2000 SL No. 90 s 6(1)
- def “**special purpose vehicle (type 2)**” om 2000 SL No. 90 s 6(1)
- def “**special purpose vehicle (type o)**” ins 2000 SL No. 90 s 6(2)
amd 2005 SL No. 188 s 74(2)
- def “**special purpose vehicle (type p)**” ins 2000 SL No. 90 s 6(2)
amd 2003 SL No. 60 s 36(5)
- def “**special purpose vehicle (type t)**” ins 2000 SL No. 90 s 6(2)
amd 2005 SL No. 188 s 74(3); 2007 SL No. 200 s 17 sch
- def “**status certificate**” ins 2005 SL No. 215 s 9
- def “**statutory authority**” om 2001 SL No. 48 s 15(1)
- def “**statutory entity**” ins 2001 SL No. 248 s 15(2)
- def “**statutory write-off**” ins 2002 SL No. 251 s 21
- def “**tandem axle group**” ins 2009 SL No. 66 s 6(1)
- def “**tare mass**” ins 2009 SL No. 65 s 27
- def “**total loss**” ins 2002 SL No. 251 s 21
- def “**Transport concession policy**” ins 2005 SL No. 131 s 14(2)
- def “**tri-axle group**” ins 2009 SL No. 66 s 6(1)
- def “**twinsteer axle group**” ins 2009 SL No. 66 s 6(1)
- def “**unrestricted access registration**” ins 2003 SL No. 60 s 36(2)
- def “**vehicle law**” sub 1999 SL No. 286 s 4 sch 2
- def “**vehicle related information**” ins 2001 SL No. 248 s 15(3)
- def “**vehicle related information provider**” ins 2001 SL No. 248 s 15(3)
amd 2007 SL No. 200 s 17 sch
- def “**written-off vehicle**” ins 2002 SL No. 251 s 21
- def “**written-off vehicle inspection**” ins 2002 SL No. 251 s 21
- def “**written-off vehicle inspection report**” ins 2002 SL No. 251 s 21
- def “**written-off vehicle inspection site**” ins 2002 SL No. 251 s 21
- def “**zone access registration**” ins 2003 SL No. 60 s 36(2)

© State of Queensland 2009