

Queensland



Transport Operations (Road Use Management) Act 1995

**TRANSPORT OPERATIONS
(ROAD USE MANAGEMENT—
VEHICLE REGISTRATION)
REGULATION 1999**

**Reprinted as in force on 1 February 2003
(includes amendments up to SL No. 366 of 2002)**

Reprint No. 2G

**This reprint is prepared by
the Office of the Queensland Parliamentary Counsel
Warning—This reprint is not an authorised copy**

Information about this reprint

This regulation is reprinted as at 1 February 2003. The reprint shows the law as amended by all amendments that commenced on or before that day (Reprints Act 1992 s 5(c)).

The reprint includes a reference to the law by which each amendment was made—see list of legislation and list of annotations in endnotes.

This page is specific to this reprint. See previous reprints for information about earlier changes made under the Reprints Act 1992. A table of reprints is included in the endnotes.

Also see endnotes for information about—

- **when provisions commenced**
- **editorial changes made in earlier reprints.**

Dates shown on reprints

Reprints dated at last amendment All reprints produced on or after 1 July 2002, hard copy and electronic, are dated as at the last date of amendment. Previously reprints were dated as at the date of publication. If a hard copy reprint is dated earlier than an electronic version published before 1 July 2002, it means the legislation was not further amended and the reprint date is the commencement of the last amendment.

If the date of a hard copy reprint is the same as the date shown for an electronic version previously published, it merely means that the electronic version was published before the hard copy version. Also, any revised edition of the previously published electronic version will have the same date as that version.

Replacement reprint date If the date of a hard copy reprint is the same as the date shown on another hard copy reprint it means that one is the replacement of the other.

Queensland



TRANSPORT OPERATIONS (ROAD USE MANAGEMENT—VEHICLE REGISTRATION) REGULATION 1999

TABLE OF PROVISIONS

Section		Page
PART 1—PRELIMINARY		
1	Short title	7
2	Commencement	7
3	Definitions	7
4	Meaning of “exempt vehicle”	7
4A	Meaning of “registered operator” in this regulation	8
5	Registered and unregistered vehicles	9
PART 2—REGISTRATION PRINCIPLES		
6	Garage address in Queensland	9
7	Persons eligible to register vehicle	9
8	Compliance with vehicle law	9
9	Proof of compliance with vehicle law	10
PART 3—VEHICLE REGISTRATION		
<i>Division 1—Vehicles used on roads must be registered</i>		
10	Vehicles used on roads must be registered	10
<i>Division 2—Registration</i>		
11	Application for registration	11
12	Registration application made by agent	12
12A	Driving or towing unregistered vehicle to place for inspection	12
13	Vehicle inspections	13
14	Determination of applications	14
15	Registered vehicles register	16

*Transport Operations (Road Use
Management—Vehicle Registration) Regulation 1999*

16	Registration certificates	18
17	Registered operator to notify change of particulars	18
18	Recording change in vehicle particulars and reassessment of registration fee	19
19	Registration term	20
20	Seasonal registration	21
21	When registration becomes effective.	21

Division 3—Limited use registration

22	Limited use registration.	22
----	-----------------------------------	----

Division 4—Number plates

23	Chief executive to assign registration number and issue number plates	23
24	Position, visibility and legibility of number plate	23
25	Time for attaching number plates	25
26	Q plates	26
27	Personalised number plates	26
28	Transfer of personalised number plate	27
29	Converting number plate to personalised number plate	28
30	Customised number plates.	28
31	Accessory plates	28
31A	Accessory plate for tow truck	29

Division 5—Registration labels

32	Chief executive to issue registration labels	30
33	Position for attaching registration label.	30
34	Time for attaching registration label	31

PART 4—RENEWAL OF REGISTRATION

36	Registration renewal notice	32
37	Renewal of registration	32
37A	When surcharge is payable for renewal.	34
37B	Registration term if overpayment or underpayment of registration-related amount and any surcharge	35
38	Issue of receipt and updating of records	36

*Transport Operations (Road Use
Management—Vehicle Registration) Regulation 1999*

PART 5—TRANSFER OF REGISTRATION

39	Transfer of registration	37
40	Failure by dealer to apply for transfer of registration	39
41	Transfer of registration under legal process	39
42	Refusing to register transfer of registration.	40

PART 6—EXPIRY AND CANCELLATION OF REGISTRATION

Division 1—Expiry of registration

43	Expiry of registration.	41
44	Return of registration plates when registration expires.	41

Division 2—Cancellation of registration

45	Cancellation of registration at registered operator’s request	41
45A	Cancellation if registration in other State	42
46	Partial refund of registration fee	43
47	Cancellation for noncompliance with defect notice	43
48	Cancellation of registration of vehicle or dealer plate.	44
49	Recording cancellation of registration in register	46

PART 7—WHEN REGISTRATION UNNECESSARY

Division 1—Unregistered vehicle permits

50	Unregistered vehicle permits	47
----	----------------------------------------	----

Division 2—Dealer plates

51	Designation of dealer plates	48
52	Registration of dealer plate	48
53	Attaching dealer plate	49
54	Use of dealer plates	49
55	Cancellation of dealer plates	51

PART 7A—WRITTEN-OFF VEHICLES

Division 1—Objects of pt 7A

55A	Objects.	52
-----	------------------	----

Division 2—Notifying of written-off vehicle information

55B	General obligations of notifiers.	53
55C	Auditing of notifiers	53
55D	Obligation of notifiers to give notifiable information	54

*Transport Operations (Road Use
Management—Vehicle Registration) Regulation 1999*

55E	Obligation of insurer to report written-off vehicle	54
55F	Obligation of self-insurer to report written-off vehicle	55
55G	Obligation of loss adjuster to report written-off vehicle	56
55H	Obligation of dealer or auctioneer to report written-off vehicle	56
55I	Obligation of auto parts dismantler to report written-off vehicle	57
55J	Obligation of registered operator or owner of unregistered vehicle to report written-off vehicle	58
55K	Notifier's obligation to tell registered operator or owner	59
55L	Obligation on notifiers to attach written-off vehicle label to written-off vehicle	59
55M	Obligation on registered operator or owner to attach written-off vehicle label to written-off vehicle	60
55N	Offence to remove written-off vehicle label	60
55O	Written-off vehicles must not be used on road	60

Division 3—Written-off vehicle inspections

55P	Definition for div 3	61
55Q	Approvals	61
55R	Conditions of approval	62
55S	Refusing to grant approval	62
55T	Approval prescribed for the Act, ss 17B(2) and 18(c)(ii)	63

Division 4—Offences relating to written-off vehicle inspections

55U	Performing written-off vehicle inspection when not approved	63
55V	Supervising written-off vehicle inspections when not approved	63
55W	Not complying with conditions of approval	63
55X	False or misleading written-off vehicle inspection report	64
55Y	Operating place as a written-off vehicle inspection site	64
55Z	Performing written-off vehicle inspection at place other than written-off vehicle inspection site	64
55ZA	Supervising written-off vehicle inspections at place other than written-off vehicle inspection site	64
55ZB	False advertising or holding out	64

PART 8—GENERAL

Division 1—Other provisions about number plates and other items

56	Replacement registration items	65
----	------------------------------------------	----

*Transport Operations (Road Use
Management—Vehicle Registration) Regulation 1999*

57	Chief executive may require exchange of number plates	66
58	Chief executive may require return of number plates	66
59	Property in number plates	67
	<i>Division 2—Vehicles temporarily in Queensland</i>	
60	Vehicles temporarily in Queensland	68
	<i>Division 3—Other miscellaneous provisions</i>	
61	Sale of unregistered vehicles by dealers	70
62	Authorisation to use unregistered vehicle on roads.	70
63	Permit to use intercepted unregistered vehicle on road.	71
64	Damaged or dirty number plates	72
	<i>Division 4—Review of decisions</i>	
65	Decision to which this division applies.	73
66	Review of decisions.	74
	<i>Division 5—Release of information</i>	
67	Definitions for div 5.	74
68	Release of information on payment of fee	77
68A	Release of vehicle related information on payment of a fee	78
	PART 9—FEES	
	<i>Division 1—General</i>	
69	Fees	78
70	Charging categories.	79
	<i>Division 2—Vehicles exempted from registration fees</i>	
71	Exemption from payment of fee	80
	<i>Division 3—Concessional registration fees for certain category 1 vehicles</i>	
72	Concessional registration fees—category 1 vehicles	81
	<i>Division 4—Concessional registration fees for category 2 vehicles</i>	
73	Concessional registration fees—primary producers	82
74	Concessional registration fee for motorised caravan for card holders	83
75	Concessional registration fees for other vehicles	84
	PART 10—OTHER OFFENCE PROVISIONS	
76	Offences involving registration certificates etc	85

*Transport Operations (Road Use
Management—Vehicle Registration) Regulation 1999*

77	Requirement to remove unlawful registration item	86
PART 11—TRANSITIONAL PROVISIONS		
<i>Division 1—Transitional provisions for Transport Operations (Road Use Management—Vehicle Registration) Regulation 1999</i>		
78	Purpose of pt 11	87
79	Definition for pt 11	87
80	Continuation of registration and other authorities under former regulation .	87
81	Postponement of particular changes until 31 December 1999	88
82	Limited use plates under former regulation	88
83	Position for attaching registration label to certain trailers.	89
<i>Division 2—Transitional provision for written-off vehicle amendments</i>		
84	Registration of vehicle recorded as a written-off vehicle under corresponding law	89
SCHEDULE 1		90
CATEGORY 1 VEHICLE REGISTRATION FEES		
SCHEDULE 2		94
CATEGORY 2 VEHICLE REGISTRATION FEES		
SCHEDULE 3		97
OTHER FEES		
SCHEDULE 4		102
DICTIONARY		
ENDNOTES		
1	Index to endnotes	119
2	Date to which amendments incorporated.	119
3	Key	119
4	Table of reprints	120
5	List of legislation	120
6	List of annotations	122

TRANSPORT OPERATIONS (ROAD USE MANAGEMENT—VEHICLE REGISTRATION) REGULATION 1999

[as amended by all amendments that commenced on or before 1 February 2003]

PART 1—PRELIMINARY

1 Short title

This regulation may be cited as the *Transport Operations (Road Use Management—Vehicle Registration) Regulation 1999*.

2 Commencement

(1) Subject to subsection (2), this regulation commences on 1 October 1999.

(2) Part 8, division 5 and schedule 3, part 2, items 2 to 4 commence on 1 January 2000.

3 Definitions

The dictionary in schedule 4 defines particular words used in this regulation.

4 Meaning of “exempt vehicle”

In this regulation, a vehicle is an “**exempt vehicle**” if the vehicle is—

- (a) an agricultural implement, if it is being towed by—
 - (i) an agricultural machine suitably matched to the implement;
or
 - (ii) another vehicle of a suitable size for towing the implement;
or

*Transport Operations (Road Use
Management—Vehicle Registration) Regulation 1999*

- (b) a trailer, if—
 - (i) it is being towed by an agricultural machine; and
 - (ii) the agricultural machine is being used for its intended agricultural purpose; or
- (c) a motorised golf buggy or other motorised machinery being used on a golf course or on a golf course car park, or a motorised golf buggy being used for directly crossing a road dividing a golf course; or
- (d) a ride-on mower, other than a ride-on mower that is an agricultural machine, that is being used for mowing, and is—
 - (i) directly crossing a road; or
 - (ii) crossing from 1 road related area to another road related area; or
 - (iii) on a road related area; or
- (e) walking speed equipment that is on a road only for—
 - (i) loading it onto, or unloading it from, another vehicle; or
 - (ii) repositioning it at a work site; or
- (f) a low powered motor vehicle; or
- (g) a vehicle that is not a motor vehicle or a trailer; or
- (h) a vehicle being towed by a tow truck operating as a tow truck; or
- (i) a racing vehicle being used on a racing track or in a related area for a racing track.

4A Meaning of “registered operator” in this regulation

(1) This section defines “**registered operator**” for its use in this regulation only, and has effect despite the expression’s definition in the Act.

(2) The “**registered operator**” of a vehicle is the person in whose name the vehicle is currently registered.

(3) The “**registered operator**” of a dealer plate is the person in whose name the dealer plate is currently registered.

5 Registered and unregistered vehicles

(1) In this regulation, a vehicle is taken to be a registered vehicle if it has current registration under this regulation.

(2) In this regulation, a vehicle is taken to be an unregistered vehicle if—

(a) it has no current registration under this regulation because—

(i) it has never had registration under this regulation; or

(ii) it has had registration under this regulation, but the registration has expired or been cancelled; and

(b) nothing in this regulation permits its use on a road, whether or not under limited circumstances.

PART 2—REGISTRATION PRINCIPLES

6 Garage address in Queensland

A vehicle may be registered in Queensland only if its garage address is in Queensland.

7 Persons eligible to register vehicle

(1) Any person may apply to the chief executive to register a category 1 vehicle in the person's name.

(2) However, a person may apply to the chief executive to register a category 2 vehicle in the person's name only if the person is a corporation or an individual aged 18 or over.

8 Compliance with vehicle law

(1) To be eligible for registration, a vehicle must conform with the requirements applying to the vehicle under each vehicle law.

(2) However, if a vehicle does not conform with the requirements applying to the vehicle under a vehicle law, the vehicle may be registered for limited use on conditions.

(3) Limited use registration for vehicles is provided for in part 3, division 3.

9 Proof of compliance with vehicle law

(1) The chief executive may accept as evidence that a vehicle conforms with the requirements applying to the vehicle under a vehicle law—

- (a) a plate attached to the vehicle under the vehicle law; or
- (b) a written statement to that effect from the vehicle's manufacturer.

(2) In the absence of evidence mentioned in subsection (1), the chief executive may, on inspecting the vehicle and being satisfied it conforms with the requirements applying to the vehicle under each vehicle law, issue a certificate to that effect.

PART 3—VEHICLE REGISTRATION

Division 1—Vehicles used on roads must be registered

10 Vehicles used on roads must be registered

A person must not use, or permit to be used, on a road a vehicle that is not a registered vehicle unless—

- (a) under section 12A or 13, the vehicle is being driven or towed to where it is to be inspected; or
- (b) the vehicle is being used under an unregistered vehicle permit under section 50; or
- (c) the vehicle is being used under the authority of a dealer plate under section 52; or
- (d) the use of the vehicle on the road is authorised under section 60;¹
or

¹ Section 60 (Vehicles temporarily in Queensland)

*Transport Operations (Road Use
Management—Vehicle Registration) Regulation 1999*

- (e) the vehicle is being used under an authorisation issued under section 62;² or
- (f) the vehicle is being used under a permit issued under section 63;³ or
- (g) the vehicle is an exempt vehicle.

Maximum penalty—80 penalty units.

Division 2—Registration

11 Application for registration

(1) An application for the registration of a vehicle must be made to the chief executive in the approved form accompanied by the following—

- (a) the relevant registration fee;
- (b) any relevant plate fee;
- (c) if the vehicle is a category 1 vehicle, the category 1 vehicle traffic improvement fee;
- (d) an insurance certificate under the *Motor Accident Insurance Act 1994* for the vehicle for the proposed registration term or the insurance premium payable under that Act for the certificate;
- (e) if the vehicle is a COI vehicle under the Vehicle Standards and Safety Regulation, a current certificate of inspection under that regulation for the vehicle, but only if, once the vehicle is registered, its owner will be required under that regulation to possess a current certificate of inspection for the vehicle;
- (f) if the vehicle is an SC vehicle under the Vehicle Standards and Safety Regulation, a current safety certificate under that regulation, unless—
 - (i) the garage address of the vehicle is in an area mentioned in schedule 2, item 4 or 5 of the Vehicle Standards and Safety Regulation; or

2 Section 62 (Authorisation to use unregistered vehicle on roads)

3 Section 63 (Permit to use intercepted unregistered vehicle on road)

*Transport Operations (Road Use
Management—Vehicle Registration) Regulation 1999*

- (ii) the vehicle has never previously been registered in Queensland, in another State or in a foreign country; or
- (iii) the vehicle is being registered in the name of a dealer for resale purposes;
- (g) any duty payable under the *Duties Act 2001*;
- (h) if applicable, a certificate of compliance under the *Gas Regulation 1989* for the vehicle.

(2) A vehicle mentioned in subsection (1)(e) or (f) must be taken with the application to the place where the application is to be given to the chief executive.

12 Registration application made by agent

(1) This section applies if the application of a person (the “**applicant**”) to register a vehicle is made by another person (the “**agent**”) as agent for the applicant.

(2) The chief executive must not grant the application unless the agent gives the chief executive satisfactory evidence of—

- (a) the agent’s identity; and
- (b) the applicant’s identity; and
- (c) the agent’s authority to act as agent for the applicant to register the vehicle.

12A Driving or towing unregistered vehicle to place for inspection

(1) This section applies if it is necessary, for registering an unregistered vehicle under this regulation, for the vehicle to be driven or towed to—

- (a) an AIS under the Vehicle Standards and Safety Regulation for inspection for obtaining an inspection certificate under that regulation; or
- (b) if the vehicle is a vehicle that is recorded in the register as a repairable write-off, a written-off vehicle inspection site for obtaining a written-off vehicle inspection report; or
- (c) another place as required by the chief executive.

*Transport Operations (Road Use
Management—Vehicle Registration) Regulation 1999*

Examples for paragraph (c)—

- A place for inspecting by the Queensland Police Service
- A place for road testing by an inspection station
- A place for having an identifying number stamped
- A place for obtaining a gas certificate or a weighbridge certificate.

(2) The vehicle may be driven or towed to the place and subsequently to an office of the chief executive where it may be registered, but only if—

- (a) an application in the approved form to register the vehicle has been completed; and
- (b) if the vehicle is required to be insured under the *Motor Accident Insurance Act 1994*, a current insurance certificate has been issued for the vehicle; and
- (c) the documents mentioned in paragraphs (a) and (b) are—
 - (i) for a trailer—carried in the motor vehicle towing the trailer; or
 - (ii) for another vehicle—carried in the vehicle.

13 Vehicle inspections

(1) The chief executive may require a vehicle to be brought to the chief executive for an inspection—

- (a) before the vehicle is registered under this regulation; or
- (b) if the vehicle is recorded in the register as a repairable write-off, before the chief executive changes the register to ensure the vehicle is no longer recorded as a repairable write-off.

(2) Subsection (3) applies if, when the chief executive inspects the vehicle—

- (a) an identifying number placed on the vehicle by the vehicle's manufacturer is not clearly legible or appears to have been altered or defaced; or
- (b) for a vehicle recorded in the register as a repairable write-off that has been repaired, the vehicle no longer has an identifying number.

(3) The chief executive—

*Transport Operations (Road Use
Management—Vehicle Registration) Regulation 1999*

- (a) may allot a replacement identifying number for the vehicle; and
- (b) must record the allotted replacement identifying number in the register.

(4) The applicant must, as soon as practicable—

- (a) take action to obtain the necessary permission under section 134⁴ of the Act to stamp the allotted replacement identifying number on the vehicle; and
- (b) if the permission is obtained, ensure the allotted replacement identifying number is stamped on the vehicle.

Maximum penalty—8 penalty units.

(5) The obligation to which the applicant is subject under subsection (4) continues to apply even if the applicant does not further pursue the registration of the vehicle.

(6) Subsection (7) applies if, after the vehicle is registered or, for a vehicle that was recorded in the register as a repairable write-off, after the chief executive has changed the register to ensure the vehicle is no longer recorded as a repairable write-off, it appears to the chief executive that there is a possible discrepancy relating to the particulars of the vehicle as registered.

(7) The registered operator of the vehicle must, if requested by written notice from the chief executive, return the vehicle for further inspection.

Maximum penalty for subsection (7)—8 penalty units.

14 Determination of applications

(1) The chief executive may refuse an application for the registration of a vehicle if the chief executive reasonably believes—

- (a) the vehicle or a part of the vehicle is, or may be, stolen; or
- (b) information given in the application is false or misleading; or
- (c) the vehicle's chassis number or VIN is the same as the chassis number or VIN of a vehicle recorded in the register, or in a register kept under a corresponding law to this regulation, as a statutory write-off; or

4 Section 134 (Alteration and defacing of numbers etc.) of the Act

*Transport Operations (Road Use
Management—Vehicle Registration) Regulation 1999*

- (d) the vehicle's chassis number or VIN is the same as the chassis number or VIN of a vehicle recorded in the register as a repairable write-off, unless there is a written-off vehicle inspection report for the vehicle; or
- (e) the vehicle's chassis number or VIN is the same as the chassis number or VIN of a vehicle recorded in a register kept under a corresponding law to this regulation as a repairable write-off, unless there is a written-off vehicle inspection report for the vehicle or, under the corresponding law, there is a report for the vehicle that is equivalent to a written-off vehicle inspection report; or
- (f) a person, by giving or purporting to give under this regulation a written-off vehicle inspection report for the vehicle, has committed an offence; or
- (g) a person, by giving or purporting to give under a corresponding law to this regulation a report that is equivalent to a written-off vehicle inspection report for the vehicle, has committed an offence; or
- (h) an approved examiner under the Vehicle Standards and Safety Regulation has, by issuing an inspection certificate for the vehicle under that regulation, contravened the Act; or
- (i) there are unpaid fines or penalties arising out of the use of the vehicle in Queensland or another State; or
- (j) the vehicle's garage address is in another State; or
- (k) the vehicle does not conform with the requirements applying to the vehicle under a vehicle law; or
- (l) the vehicle has been registered in another State and—
 - (i) the registration in the other State has been suspended or cancelled for a reason other than its expiry; and
 - (ii) the reasons for the cancellation or suspension still exist.

(2) Subsection (1) does not limit the chief executive's power to refuse the application under another provision of this regulation.

(2A) Despite subsection (1), the chief executive may decide that a written-off vehicle inspection report is not required for a vehicle that is recorded in the register, or in a register kept under a corresponding law to this regulation, as a repairable write-off.

*Transport Operations (Road Use
Management—Vehicle Registration) Regulation 1999*

Example—

The chief executive decides the damage to a vehicle is limited to cosmetic damage.

(3) If the chief executive decides to grant the application, the chief executive must register the vehicle in the applicant's name.

(4) If the chief executive decides to refuse the application, the chief executive must tell the applicant—

- (a) the reasons for the refusal; and
- (b) that the decision may be reviewed under section 66,⁵ unless the vehicle's chassis number or VIN is the same as the chassis number or VIN of a vehicle recorded in the register, or in a register kept under a corresponding law to this regulation, as a statutory write-off.

(5) If asked by the applicant, the chief executive must give written reasons for refusing the application.

15 Registered vehicles register

(1) The chief executive must keep a register of registered vehicles (the “**register**”).

(2) The register must contain the following particulars for each registered vehicle, to the extent the particulars are applicable for the vehicle—

- (a) the registered operator's name;
- (b) the vehicle's registration number and other identification details;
- (c) the vehicle's GVM or GCM;
- (d) the vehicle's garage address;
- (e) the registered operator's address;
- (f) for a vehicle registered for limited use—identification of the conditions of use;
- (g) the commencement and expiry days for the registration;
- (h) for a category 2 vehicle—the vehicle's nominated configuration.

5 Section 66 (Review of decisions)

*Transport Operations (Road Use
Management—Vehicle Registration) Regulation 1999*

(3) The chief executive must ensure the register contains the particulars of each vehicle that—

- (a) is currently registered; or
- (b) is not currently registered, but has been a registered vehicle within the previous 2 years.

(4) The register must also contain the notifiable information about a written-off vehicle notified under part 7A, whether or not the vehicle is currently registered.

(5) However, subsection (6) applies if—

- (a) for a vehicle recorded in the register as a repairable write-off, there is a written-off vehicle inspection report for the vehicle; or
- (b) for a vehicle recorded in a register kept under a corresponding law to this regulation, there is under the corresponding law a report for the vehicle that is equivalent to a written-off vehicle inspection report.

(6) The chief executive must change the register to ensure the vehicle is no longer recorded as a repairable write-off.

(7) The chief executive may record in the register other information—

- (a) required to be recorded under the Act or another Act; or
- (b) the chief executive decides is appropriate.

Examples of information the chief executive could decide to record under subsection (7)(b)—

1. Odometer readings to help in consumer protection.
2. Pension details for managing concessional registration schemes.

(8) Despite anything else in this regulation—

- (a) the chief executive is not required to make sure that the person whose name is shown in the register as the registered operator of a vehicle is a person who has title to the vehicle; and
- (b) the register is not intended to be a means by which the title to a registered vehicle may be conclusively established.

16 Registration certificates

(1) If the chief executive registers a vehicle, the chief executive must issue a registration certificate to the applicant for the vehicle.

(2) The certificate must include the following particulars, to the extent the particulars are applicable for the vehicle—

- (a) the registered operator's name and address;
- (b) the vehicle's garage address;
- (c) the vehicle's registration number;
- (d) the make of the vehicle;
- (e) the vehicle's VIN or, if there is no VIN, the vehicle's chassis number or engine number;
- (f) the vehicle's GCM or GVM;
- (g) the vehicle charging category;
- (h) the commencement and expiry days for the registration;
- (i) if the vehicle is registered for limited use, identification of the conditions of use.

(3) The chief executive may also include in the certificate any other information the chief executive decides appropriate.

17 Registered operator to notify change of particulars

(1) The registered operator of a vehicle must, within 14 days after the person's address, or the garage address of the vehicle, is changed, give the chief executive full particulars of the change.

Maximum penalty—8 penalty units.

(2) The registered operator of a vehicle must, within 14 days after the person's name is changed, give the chief executive—

- (a) written notice containing full particulars of the change; and
- (b) suitable material in writing evidencing the change.

Maximum penalty—8 penalty units.

*Transport Operations (Road Use
Management—Vehicle Registration) Regulation 1999*

(3) If a person modifies a registered vehicle, the registered operator of the vehicle must give the chief executive written notice containing full particulars of the modification within 14 days after the modification.

Maximum penalty—8 penalty units.

(4) The registered operator must not use the vehicle on a road until the chief executive has been notified of the modification, and any additional registration fee or charge attributable to the modification has been paid to the chief executive, if—

- (a) the vehicle is a category 2 vehicle; and
- (b) at least 1 of the following applies—
 - (i) the modification is to the vehicle’s description as recorded in the register;
 - (ii) because of the modification, the registration fee applicable to the vehicle is higher than the fee paid for its current registration.

Maximum penalty—80 penalty units.

(5) In this section—

“**modifies a registered vehicle**” means modifies any of the following—

- (a) the vehicle’s axle configuration;
- (b) the vehicle’s carrying capacity;
- (c) the vehicle’s description as recorded in the register;
- (d) the method of propulsion of the vehicle;
- (e) the vehicle’s GCM or GVM;
- (f) any other particular of the vehicle recorded in the register.

18 Recording change in vehicle particulars and reassessment of registration fee

(1) If the chief executive is satisfied the particulars given under section 17 are correct, the chief executive, must—

- (a) record the correct name, address or particulars in the register; and
- (b) issue an updated registration certificate; and

*Transport Operations (Road Use
Management—Vehicle Registration) Regulation 1999*

- (c) if the details on the registration label issued for the vehicle have changed, issue a replacement registration label.

(1A) However, the chief executive must not act under subsection (1) to record an identifying number of a vehicle that is recorded in the register as a written-off vehicle, other than if the chief executive allots a replacement identifying number for the vehicle under section 13.

(2) Also, if the particulars are for the modification of a vehicle, the chief executive may reassess the registration fee payable for the vehicle for the term (the “**unexpired term**”) from when the vehicle was modified to the end of the vehicle’s current registration.

(3) The chief executive must as soon as practicable refund to the registered operator any amount by which the reassessed fee is less than the fee already paid for the unexpired term.

(4) The chief executive may, by written notice given to the registered operator, require the registered operator to pay any amount by which the reassessed fee is more than the fee already paid for the unexpired term within 28 days after the notice is given.

(5) The registered operator must comply with the requirement unless the registered operator has a reasonable excuse.

Maximum penalty—60 penalty units.

19 Registration term

A vehicle may be registered for the term asked for by the applicant from the following terms—

- (a) 1 year;
- (b) 6 months;
- (c) if the vehicle is a category 2 vehicle, 3 months;
- (d) another term the chief executive considers reasonable and appropriate, having regard to the administrative needs of the applicant.

20 Seasonal registration

(1) A vehicle owned by a primary producer may be registered for 3 or 6 months if it is used only in the registered operator's business as a primary producer.

(2) A vehicle used only seasonally may be registered for 3 or 6 months if it is used only to transport primary produce from a farm or fishing waters to where the primary produce is—

- (a) loaded onto a train, vessel or another vehicle; or
- (b) stored before being processed; or
- (c) the subject of the first processing step applied to it; or
- (d) processed.

(3) At the end of the registration term, the registration of a vehicle under subsection (1) or (2) may be—

- (a) renewed for 3 months or 6 months; or
- (b) deferred for not longer than 1 year and then renewed.

(4) Subsection (3) does not stop the registration of a vehicle being—

- (a) renewed for a term for which vehicles are usually registered under section 19; or
- (b) cancelled under part 6.⁶

(5) In this section—

“vehicle” means—

- (a) a prime mover or truck with a GVM of 6 t or over 6 t; or
- (b) a trailer with an MRC over 4.5 t.

21 When registration becomes effective

The registration of a vehicle is effective on the issue of the chief executive's receipt for payment.

⁶ Part 6 (Expiry and cancellation of registration)

Division 3—Limited use registration

22 Limited use registration

(1) This section applies to a vehicle if—

- (a) the vehicle is, or vehicles of its type are, the subject of a guideline under section 11A⁷ of the Road Use Management Regulation for the safe movement of the vehicle or type of vehicle on a road; and
- (b) 1 of the following applies—
 - (i) the vehicle does not conform with the requirements applying to the vehicle under a vehicle law;
 - (ii) the vehicle is used primarily for off road use but is used occasionally, or has restricted use, on a road;
 - (iii) the vehicle is a special purpose vehicle (type p).

Example of paragraph (b)(ii)—

A farmer owns separate paddocks a short distance apart adjoining a road and drives a vehicle on the road to take it from one paddock to another.

(2) The chief executive may register the vehicle for limited use.

(3) However, the chief executive must not register the vehicle for limited use unless the chief executive is satisfied the vehicle conforms with the guideline.

(4) A person who uses a vehicle registered for limited use must comply with the conditions for use stated in the guideline applying to the vehicle.

Maximum penalty—30 penalty units.

⁷ Section 11A (Guidelines and permits for vehicles) of the Road Use Management Regulation

Division 4—Number plates

23 Chief executive to assign registration number and issue number plates

- (1) If the chief executive registers a vehicle, the chief executive must—
- (a) assign a distinguishing registration number to the vehicle; and
 - (b) issue to the registered operator of the vehicle the number plates displaying the assigned number required under subsection (2).
- (2) The chief executive must issue—
- (a) if the vehicle is a motorbike, trailer or tractor, other than a tractor registered for limited use—1 number plate; or
 - (b) if the vehicle is a vehicle other than a vehicle mentioned in paragraph (a)—2 number plates.

24 Position, visibility and legibility of number plate

- (1) The registered operator of a vehicle must ensure that each number plate issued for a vehicle is permanently attached to the vehicle so that, if the vehicle is on level ground—
- (a) the number plate is—
 - (i) in an upright position parallel to the vehicle's axles; and
 - (ii) not more than 1.3 m above ground level; and
 - (b) unless an accessory plate is attached to the vehicle in the way required under section 31,⁸ the characters on the number plate are visible from 20 m away at any point within an arc of 45 degrees from the surface of the number plate above or to either side of the vehicle, in the way shown in figures 1 and 2 at the end of this section; and
 - (c) any cover on the number plate—
 - (i) is clear, clean, untinted and flat over its entire surface; and
 - (ii) has no reflective or other characteristics that would prevent—

8 Section 31 (Accessory plates)

*Transport Operations (Road Use
Management—Vehicle Registration) Regulation 1999*

- (A) the successful operation of a photographic detection device; or
- (B) the number plate from being legible; and
- (d) the number plate is in a clearly legible condition, including being clearly legible from any position from which it is required to be visible.

Maximum penalty—40 penalty units.

(2) The registered operator must also ensure that—

- (a) if the vehicle has been issued with 2 number plates—1 number plate is attached to the front of the vehicle and the other to its rear; or
- (b) if the vehicle has been issued with only 1 number plate—the number plate is attached to its rear.

Maximum penalty—12 penalty units.

(3) The registered operator does not contravene subsection (1)(a) or (b) if—

- (a) it is not practicable to attach a number plate to the vehicle in the way required under subsection (1)(a) or (b) because of the vehicle's construction; and
- (b) the registered operator attaches the number plate to the vehicle as nearly as practicable in the way required under subsection (1)(a) or (b).

(4) The registered operator does not contravene subsection (1)(b) if—

- (a) the position for the rear number plate of the vehicle (the **“towing vehicle”**) is obscured by another vehicle (the **“towed vehicle”**) being towed by the towing vehicle; and
- (b) either—
 - (i) the towed vehicle is registered under this regulation or a corresponding law to this regulation, and displays its rear number plate in the way required under subsection (1) or under the corresponding law; or
 - (ii) the towing vehicle is a tow truck, the towed vehicle is not registered under this regulation or a corresponding law to this regulation, and the towed vehicle—

*Transport Operations (Road Use
Management—Vehicle Registration) Regulation 1999*

- (A) displays the towing vehicle’s rear number plate in a way consistent with the requirements of subsection (1); or
- (B) displays an accessory plate for the towing vehicle in the way required under section 31A(5).

(5) In this section—

“**number plate**” does not include an accessory plate issued under section 31.

“**photographic detection device**” has the meaning given by the *Transport Operations (Road Use Management) Act 1995*, section 113.

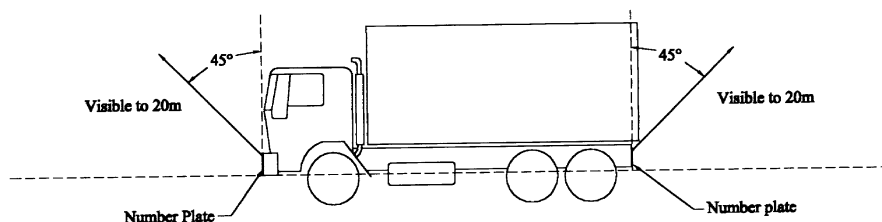

Figure 1

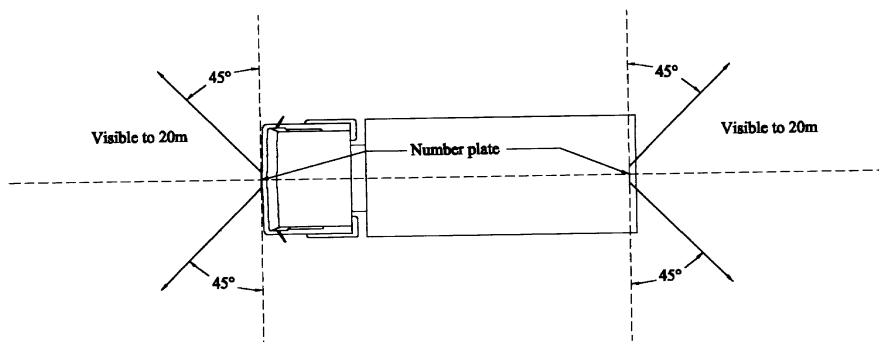

Figure 2

25 Time for attaching number plates

(1) The registered operator of a vehicle must attach to the vehicle a number plate issued for the vehicle within 1 day after receiving the number plate.

Maximum penalty—12 penalty units.

*Transport Operations (Road Use
Management—Vehicle Registration) Regulation 1999*

(2) The registered operator of a vehicle must attach to the vehicle a special plate the registered operator holds for the vehicle within 1 day after receiving a registration certificate showing the number of the special plate as the registration number of the vehicle.

Maximum penalty—12 penalty units.

26 Q plates

(1) A person must not manufacture a replacement Q plate unless the person—

- (a) has written approval from the chief executive to manufacture the plate; and
- (b) manufactures the plate under the specifications for the plate stated in the approval.

Maximum penalty—12 penalty units.

(2) A replacement Q plate manufactured under subsection (1) is taken to have been issued by the chief executive.

(3) In this section—

“Q plate” means a number plate the number of which consists of the letter ‘Q’ followed by at least 1, but not more than 6, figures.

27 Personalised number plates

(1) The chief executive may issue a number plate as a personalised number plate—

- (a) on receipt of—
 - (i) an application in the approved form; and
 - (ii) an amount determined by the chief executive; or
- (b) on a sale at public auction for an amount acceptable to the chief executive.

(2) When the chief executive issues a personalised number plate, the chief executive must—

- (a) assign a registration number; and
- (b) record information relating to the plate in the register; and

*Transport Operations (Road Use
Management—Vehicle Registration) Regulation 1999*

(c) issue to the applicant a certificate stating the particulars of the plate.

(3) The right to use the number on a personalised number plate issued to a person is the property of the person to whom the plate is issued.

(4) A personalised number plate may be—

- (a) kept without being attached to a vehicle; or
- (b) subject to subsection (5), attached to a vehicle; or
- (c) surrendered to the chief executive for cancellation.

(5) A person must not attach a personalised number plate to a vehicle until the person has—

- (a) applied to the chief executive in the approved form; and
- (b) received a registration certificate showing the number of the personalised number plate as the registration number for the vehicle.

Maximum penalty—12 penalty units.

(6) The chief executive must not issue a personalised number plate if the number of the plate is identical, or appears to be identical, to the number of another number plate that is currently issued.

(7) If a person surrenders a personalised number plate to the chief executive for cancellation, subsection (3) no longer applies to the personalised number plate.

28 Transfer of personalised number plate

(1) A personalised number plate, including the right to use the number on the personalised number plate, is transferable.

(2) A person to whom a personalised number plate is transferred, including a person administering an estate, must within 14 days after the transfer—

- (a) notify the chief executive of the transfer in writing; and
- (b) pay the relevant fee.

Maximum penalty—16 penalty units.

(3) A person must not transfer a personalised number plate on its own if it is one of a pair.

Maximum penalty—16 penalty units.

29 Converting number plate to personalised number plate

A person may, on payment of an amount decided by the chief executive, apply to the chief executive to convert a number plate to a personalised number plate.

30 Customised number plates

(1) The registered operator of a vehicle may apply to the chief executive to customise the vehicle's number plate or a previously issued number plate.

(2) Once the number plate has been customised, the registered operator may—

- (a) keep the number plate without attaching it to a vehicle; or
- (b) apply to the chief executive in the approved form to attach it to a vehicle owned by the registered operator.

(3) A person must not attach a customised number plate to a vehicle unless—

- (a) the chief executive gives the person a registration certificate showing the number of the customised number plate as the registration number for the vehicle; and
- (b) the customised number plate is attached to the vehicle under any directions given by the chief executive.

Maximum penalty—12 penalty units.

31 Accessory plates

(1) This section applies if the chief executive has issued a special plate to a person.

(2) The person may apply to the chief executive for an accessory plate for an accessory that is to be attached to a vehicle to which the special plate may be attached.

*Transport Operations (Road Use
Management—Vehicle Registration) Regulation 1999*

(3) The accessory plate must display the same registration number as the special plate.

(4) The application must be in the approved form and accompanied by the relevant fee.

(5) If the chief executive decides to issue the plate, the chief executive must issue the plate as soon as convenient after the plate has been prepared.

(6) A person who attaches an accessory plate to a vehicle must attach the plate—

- (a) at the rear of the accessory; and
- (b) in a way that allows the accessory plate to be legible from a distance of at least 20 m from the rear of the accessory.

Maximum penalty—12 penalty units.

(7) In this section—

“**accessory**” means a bike rack or other device attached to the rear of a vehicle in a way that obscures or restricts the visibility of the vehicle’s rear number plate.

31A Accessory plate for tow truck

(1) The registered operator of a tow truck may apply to the chief executive for an accessory plate to be attached to unregistered vehicles when towed by the tow truck.

(2) The accessory plate must display the same registration number as each number plate for the tow truck.

(3) The application must be in the approved form and accompanied by the relevant fee.

(4) If the chief executive decides to issue the plate, the chief executive must issue the plate as soon as convenient after the plate has been prepared.

(5) A person who attaches an accessory plate for a tow truck to an unregistered vehicle to be towed by the tow truck must attach it to the rearmost end of the vehicle, as towed, in a way that is as nearly as practicable in the same way a number plate would be required to be attached to that end of the vehicle were it a registered vehicle.

Maximum penalty—12 penalty units.

Division 5—Registration labels

32 Chief executive to issue registration labels

(1) When a vehicle is registered, the chief executive must issue a label for the vehicle to its registered operator.

(2) The label must be in the approved form and include the following particulars for the vehicle—

- (a) its registration number;
- (b) its make;
- (c) its model or body type, according to which is the more descriptive;
- (d) its VIN or, if the vehicle does not have a VIN, the vehicle's chassis number or engine number;
- (e) the expiry day of its registration;
- (f) if the vehicle is registered for limited use, identification of the conditions of use;
- (g) its GCM and GVM;
- (h) the vehicle charging category code.

(3) This section does not apply to a tractor unless the tractor is registered for limited use.

33 Position for attaching registration label

(1) The registered operator of a vehicle must attach the vehicle's registration label to the vehicle—

- (a) so as to be clearly visible from outside the vehicle; and
- (b) in a way complying with subsections (2) to (6).

Maximum penalty—6 penalty units.

(2) If the vehicle is a motorbike, the label must be placed in a holder attached to the motorbike on the left-hand side or rear of the motorbike.

(3) If the vehicle is a trailer that is a category 1 vehicle, the label must be placed to the left-hand side or rear of the trailer.

*Transport Operations (Road Use
Management—Vehicle Registration) Regulation 1999*

(4) If the vehicle is a trailer that is a category 2 vehicle, the label must be placed on or adjacent to the trailer's number plate.

(5) If the vehicle is other than a vehicle mentioned in subsections (2) to (4) and has a windscreen, the label must be placed—

- (a) to the lower left-hand corner of the vehicle's windscreen; or
- (b) to a fixed or pivoted window on the left-hand side of the vehicle.

(6) If the vehicle is other than a vehicle mentioned in subsections (2) to (4) and does not have a windscreen, the label must be attached, whether or not by a holder, to the left-hand side of the vehicle as near as practicable to the position mentioned in subsection (5)(a).

(7) The registered operator must take the registration label off the vehicle and destroy it immediately on the sooner of the following—

- (a) the day another registration label issued for the vehicle is attached to the vehicle;
- (b) 21 days after the expiry day of the registration to which the registration label relates.

Maximum penalty—6 penalty units.

34 Time for attaching registration label

(1) The registered operator of a vehicle must attach the vehicle's registration label to the vehicle—

- (a) for a label issued on initial registration—within 21 days after the application for registration is made; or
- (b) for a label issued on an application for renewal of registration—
 - (i) if the label is issued before the registration expires—within 21 days after the registration expires; or
 - (ii) if the label is issued after the registration expires—within 21 days after the application is made; or
- (c) for a replacement label—
 - (i) if the label is issued on an application for a replacement label—within 21 days after the application is made; or

*Transport Operations (Road Use
Management—Vehicle Registration) Regulation 1999*

- (ii) if the label is issued as an updated registration label—within 21 days after the chief executive is notified of the matters requiring the issue of an updated registration label.

Maximum penalty—6 penalty units.

(2) A person does not contravene subsection (1) if it is not reasonably practicable to attach the label within the required time because of a delay by the chief executive in issuing the label.

PART 4—RENEWAL OF REGISTRATION

36 Registration renewal notice

(1) A registration renewal notice (a “**renewal notice**”) for a registered vehicle is a notice sent by the chief executive—

- (a) addressed to—
 - (i) if the vehicle’s registered operator has given the chief executive a written direction to address the notice to another person—the person; or
 - (ii) otherwise—the vehicle’s registered operator; and
- (b) stating that, if the vehicle’s registration is not renewed on or before a stated day, it expires.

(2) However, if the chief executive does not send, or the registered operator does not receive, a renewal notice, the non-receipt of the notice does not affect—

- (a) the expiry of the vehicle’s registration; or
- (b) the registered operator’s obligation to renew the vehicle’s registration before it expires, if the registered operator intends to use the vehicle on a road after the existing registration expires.

37 Renewal of registration

(1) A vehicle’s registration may be renewed by presenting the renewal notice, or a written request to renew the vehicle’s registration, to the chief executive together with the following—

*Transport Operations (Road Use
Management—Vehicle Registration) Regulation 1999*

- (a) the relevant registration fee;
- (b) if the vehicle is a category 1 vehicle, the category 1 vehicle traffic improvement fee;
- (c) an insurance certificate under the *Motor Accident Insurance Act 1994* for the vehicle for the proposed term of registration or the insurance premium payable under that Act for the certificate;
- (d) if the vehicle is a COI vehicle under the Vehicle Standards and Safety Regulation, a current certificate of inspection under that regulation for the vehicle, but only if its owner is required under that regulation to possess a current certificate of inspection for the vehicle.

(2) The person renewing the registration must nominate the registration term for the vehicle.

(3) The registration term must be a term available under section 19 or 37B or permitted under section 20.

(4) The registration of a vehicle may be renewed—

- (a) if the vehicle is registered for a term permitted under section 20—not more than 1 year after its registration expires; or
- (b) otherwise—not more than 2 months after its registration expires.

(5) Despite subsection (4), the chief executive may accept an application for renewal of registration at any time if the chief executive considers it reasonable in the circumstances to do so.

(6) The expiry day of a renewed term of registration for a vehicle must be worked out as if the renewal had commenced—

- (a) if the vehicle is registered for a term permitted under section 20—on the first day of the nominated term; or
- (b) otherwise—on the day after the day recorded in the register as the expiry day of the registration being renewed.

(7) Subsections (4) to (6) do not have the effect of retrospectively registering a vehicle.

(8) If the period by which a vehicle's registration may be renewed has ended but the registration has not been renewed, the chief executive may, by written notice given to the person who was recorded as the vehicle's registered operator before the registration expired, require the person to

*Transport Operations (Road Use
Management—Vehicle Registration) Regulation 1999*

return the vehicle's number plates to the chief executive within 14 days after the notice is given.

(9) A person of whom a requirement is made under subsection (8) must not contravene the requirement, unless the person has a reasonable excuse.

Maximum penalty—20 penalty units.

(10) Despite anything in subsections (1) to (9), a person may renew a vehicle's registration using the chief executive's caller activated vehicle registration telephone renewal service if the service is available for the particular renewal.

(11) Despite anything in subsections (1) to (10), the chief executive may refuse an application for the renewal of the registration of a vehicle under the same circumstances, and in the same way, that the chief executive may refuse an application for the registration of a vehicle under section 14.⁹

37A When surcharge is payable for renewal

(1) This section applies if—

- (a) an applicant for renewal of registration for a vehicle is not required to pay a CTP insurance premium to the chief executive under section 37(1)(c) in relation to the renewal; and
- (b) the applicant underpays the registration-related amount for the renewal by more than \$1.

(2) This section also applies if—

- (a) an applicant for renewal of registration for a vehicle is required to pay a CTP insurance premium to the chief executive under section 37(1)(c) in relation to the renewal; and
- (b) the amount paid by the applicant for the purpose of the registration-related amount for the renewal is more than \$1 below what the registration-related amount would be if—
 - (i) the relevant registration fee payable under section 37(1)(a) for the renewal were for 1 year's registration; and
 - (ii) the CTP insurance premium payable under section 37(1)(c) in relation to the renewal were the lowest premium set by

9 Section 14 (Determination of applications)

*Transport Operations (Road Use
Management—Vehicle Registration) Regulation 1999*

any CTP insurer for insurance covering 1 year's registration.

(3) The applicant under subsection (1) or (2) must pay the surcharge provided for in schedule 3.

37B Registration term if overpayment or underpayment of registration-related amount and any surcharge

(1) This section applies if an applicant for renewal of registration for a vehicle—

- (a) does not present an insurance certificate under the *Motor Accident Insurance Act 1994* for the vehicle for the proposed term of registration to the chief executive under section 37(1)(c); and
- (b) overpays or underpays the total of the registration-related amount for the renewal and any surcharge payable for the renewal.

(2) Despite section 19,¹⁰ the registration may be renewed for a term that is in proportion to the amount paid after deducting—

- (a) any surcharge payable for the renewal; and
- (b) any administrative fee for late payment payable for the renewal.

(3) However, the registration must not be renewed under subsection (2) if the amount paid is more than \$1 below what the total of the registration-related amount for the renewal and any surcharge payable for the renewal would be if any CTP insurance premium, payable under section 37(1)(c) in relation to the renewal, for the minimum available registration term for the vehicle, were the lowest premium set by any CTP insurer.

(4) Also, if the amount paid is more than the registration-related amount for the renewal that would be payable if the registration were to be renewed for 14 months—

- (a) the vehicle's registration may only be renewed for 1 year; and
- (b) the difference between the amount paid and the registration-related amount for the 1 year renewal must be refunded.

10 Section 19 (Registration term)

*Transport Operations (Road Use
Management—Vehicle Registration) Regulation 1999*

(5) If the term of registration would, other than for this subsection, not be a whole number of days—

- (a) the term must be rounded down to the nearest whole day; and
- (b) the difference between the amount paid and the total of the registration-related amount for the renewal and any surcharge payable for the renewal must be credited to the applicant.

(6) If subsection (3) applies, the chief executive must refund the amount paid to the applicant.

(7) The chief executive must give the applicant a written notice stating—

- (a) the term of registration for the vehicle; or
- (b) that the amount paid is being refunded because it is below the minimum required to enable renewal of registration.

38 Issue of receipt and updating of records

(1) The renewal of the registration of a vehicle is effective on the issue of the chief executive's receipt for payment.

(2) However, if the chief executive's receipt for payment for the renewal of a registration is issued before the term of the registration being renewed expires, the renewal takes effect immediately after the expiry.

(3) If the chief executive renews the registration of a vehicle, the chief executive must—

- (a) update the records for the vehicle in the register; and
- (b) issue to the registered operator—
 - (i) an updated registration certificate; and
 - (ii) a registration label.

(4) Subsection (3)(b)(ii) applies only if the vehicle is a vehicle for which a registration label is required to be issued when the vehicle is registered.

PART 5—TRANSFER OF REGISTRATION

39 Transfer of registration

(1) A person who buys or otherwise acquires, a registered vehicle must apply to the chief executive for transfer of the vehicle's registration within 14 days after acquiring it.

Maximum penalty—16 penalty units.

(2) The application must be in the approved form and accompanied by the following, to the extent they are applicable—

- (a) the relevant fee;
- (b) any other amounts due, including fees payable for the renewal of the vehicle's registration;
- (c) the duty payable under the *Duties Act 2001*;
- (d) a certificate of compliance under the *Gas Regulation 1989* for the vehicle;
- (e) if the purchase or other acquisition of the registered vehicle is a disposal for which, under the Vehicle Standards and Safety Regulation, a current inspection certificate is required, a current inspection certificate under that regulation for the vehicle.

(3) However, subsection (2)(a) to (c) does not apply to a transfer lodged under subsection (7).

(4) A dealer who acquires a registered vehicle must notify the chief executive of the acquisition in the approved form within 14 days after the acquisition.

Maximum penalty—16 penalty units.

(5) All amounts payable under subsection (2)(a) and (c) are payable by the person who acquires a vehicle from the day of transfer appearing in the application form.

(6) If a person who acquires a registered vehicle can not find out the full name and address of the person who sold or disposed of the vehicle or obtain the signature of the person who sold or disposed of the vehicle on an approved form, the person acquiring the vehicle must give a written statement to that effect to the chief executive.

*Transport Operations (Road Use
Management—Vehicle Registration) Regulation 1999*

(7) If a person (the “**disposer**”) disposes of a registered vehicle to someone else (the “**acquirer**”) and reasonably believes the acquirer has not applied for transfer of the vehicle’s registration within 14 days after acquiring it, the disposer may—

- (a) apply in the approved form for transfer of the vehicle’s registration to the acquirer; or
- (b) give notice (a “**disposal notice**”) to the chief executive, in the approved form, of the disposer’s disposal to the acquirer.

(8) The chief executive, on receipt of an application under subsection (1) or (7)(a), or a notification under subsection (4), or on being satisfied as to the correctness of the information contained in a statement received under subsection (6), may—

- (a) record in the register the day of the transfer appearing in the approved form; and
- (b) substitute the name and address of the person acquiring the vehicle for those of the registered operator recorded in the register; and
- (c) issue an updated registration certificate.

(9) On receipt of a disposal notice under subsection (7)(b), the chief executive may—

- (a) record in the register the day of disposal stated in the notice; and
- (b) substitute the name and address of the acquirer of the vehicle for those of the registered operator recorded in the register; and
- (c) by written notice given to the acquirer, require the acquirer to apply for transfer of the vehicle’s registration within 14 days after the notice is given.

(10) The acquirer must not contravene the requirement mentioned in subsection (9)(c) unless the acquirer has a reasonable excuse.

Maximum penalty—16 penalty units.

(11) If the chief executive acts under subsection (9), the person in whose name the vehicle is registered or recorded in the register under a disposal notice is taken to be the vehicle’s registered operator for this regulation until the chief executive receives notice of the transfer or disposal of a vehicle.

40 Failure by dealer to apply for transfer of registration

(1) This section applies if—

- (a) a person (the “**buyer**”) buys or otherwise acquires a registered vehicle from a dealer; and
- (b) the dealer accepts from the buyer an amount mentioned in section 39(2)(a), (b) or (c).

(2) The dealer must, within 14 days after the buyer’s acquisition of the vehicle, apply to the chief executive on the buyer’s behalf for transfer of the vehicle’s registration.

Maximum penalty—16 penalty units.

(3) The buyer does not contravene section 39(1) if an application is not made to the chief executive for transfer of the vehicle’s registration within 14 days after the buyer’s acquisition of the vehicle.

41 Transfer of registration under legal process

(1) A person who obtains a registered vehicle under a legal process must notify the chief executive in the approved form within 14 days after obtaining the vehicle.

Maximum penalty—16 penalty units.

(2) A person who repossesses a registered vehicle that is not redeemed within 28 days after the repossession must, within a further 7 days, notify the chief executive in the approved form.

Maximum penalty—16 penalty units.

(3) A person mentioned in subsection (1) or (2) (the “**new owner**”) who can not obtain the signature of the vehicle’s registered operator on the approved form, must give a written statement to that effect to the chief executive.

(4) Subsection (5) applies if the chief executive is satisfied—

- (a) the information contained in a statement received under subsection (3) is correct; and
- (b) the new owner has a lawful entitlement to the vehicle.

(5) The chief executive may—

*Transport Operations (Road Use
Management—Vehicle Registration) Regulation 1999*

- (a) record the day of the transfer appearing in the approved form in the register; and
- (b) substitute the new owner's name and address for those of the registered operator recorded in the register; and
- (c) give the new registered operator an updated registration certificate.

(6) A notification in the approved form under subsection (1) or (2) must be accompanied by the amounts, and by the documents, that would be required under section 39(2)¹¹ were the notification an application for a transfer of the vehicle's registration.

42 Refusing to register transfer of registration

(1) The chief executive may refuse to register a transfer of a vehicle's registration if—

- (a) the vehicle is registered for limited use, and a condition included in the relevant guideline is that the registration is not transferable; or
- (b) the chief executive reasonably believes there is uncertainty about the ownership, possession or control of the vehicle or that the description of the vehicle as recorded in the register may be inaccurate; or
- (c) were the vehicle to be the subject of an application for registration, the chief executive would refuse the application.

(2) If an order of an Australian court prohibits the transfer of a vehicle's registration and the chief executive has notice of the order, the chief executive must not register a transfer of the registration.

(3) Subsections (1) and (2) do not limit the chief executive's power to refuse to register the transfer of a vehicle's registration.

11 Section 39 (Transfer of registration)

PART 6—EXPIRY AND CANCELLATION OF REGISTRATION

Division 1—Expiry of registration

43 Expiry of registration

A vehicle's registration expires at the end of the day recorded in the register as the expiry day of the registration unless the registration is sooner cancelled or renewed under this regulation.

44 Return of registration plates when registration expires

(1) The chief executive may by written notice given to the person who was the registered operator of a vehicle whose registration has expired, require the person to return the vehicle's number plates to the chief executive within 14 days of the date of the notice (the “**return period**”).

(2) The person must, within the return period—

- (a) return the vehicle's number plates to the chief executive; or
- (b) if the plates have been lost, stolen or destroyed, notify the chief executive in writing of the details of the loss, theft or destruction.

Maximum penalty—20 penalty units.

Division 2—Cancellation of registration

45 Cancellation of registration at registered operator's request

(1) The registered operator of a vehicle may apply to the chief executive to cancel the vehicle's registration if—

- (a) the registered operator of the vehicle is a dealer, and the vehicle is for sale; or
- (b) the vehicle—
 - (i) has been stolen; or

*Transport Operations (Road Use
Management—Vehicle Registration) Regulation 1999*

- (ii) has been taken out of the State; or
- (iii) has ceased to be used on roads; or
- (iv) is a total loss.

(2) Also, a person acting under the authority of a court to sell a vehicle may apply to the chief executive to cancel the vehicle's registration.

(3) If the application of a person (the “**applicant**”) to cancel a vehicle's registration is made by another person on behalf of the applicant, the other person must give the chief executive written evidence of the other person's appointment, as the registered operator's agent, with the application.

(4) If a person acting under the authority of a court to sell a vehicle applies to the chief executive to cancel the vehicle's registration, the person must give the chief executive, with the application, written evidence of the person's authority to sell the vehicle.

(5) A person applying under subsection (1) or (2) must include with the application—

- (a) if the registration label or a number plate has been lost, stolen or destroyed—each item that has not been lost, stolen or destroyed, and a statement advising of the loss, theft or destruction of the other item or items; or
- (b) if paragraph (a) does not apply—the registration label and each number plate for the vehicle.

(5A) Also, if the vehicle is a total loss, the person must include with the application the notifiable information for the vehicle the person would have been required to give the chief executive under section 55J.

(6) The chief executive must cancel the vehicle's registration unless—

- (a) the applicant has not complied with subsection (3), (4), (5) or (5A); or
- (b) the chief executive is already taking action to cancel the registration because of a ground existing under section 47 or 48.

45A Cancellation if registration in other State

The chief executive may cancel a vehicle's registration other than on a person's application if the chief executive knows that the vehicle has been registered in another State under a corresponding law to this regulation.

46 Partial refund of registration fee

(1) This section applies if a vehicle's registration is cancelled under section 45 or 45A.

(2) The chief executive must make a partial refund of the registration fee paid for the vehicle to the person who was the registered operator immediately before the cancellation.

(3) The refund is worked out using the following formula—

$$\text{refund} = \frac{\text{number of days}}{365} \times \text{annual registration fee}$$

where—

“**number of days**” is the number of unexpired whole days of the registration term for which the fee was paid, from the day on which the chief executive approves the application to cancel the registration.

(4) However, the chief executive may deduct from the refund—

- (a) an amount decided by the chief executive to cover reasonable administrative costs; and
- (b) any unpaid fees payable under a transport Act for the vehicle.

47 Cancellation for noncompliance with defect notice

(1) A ground exists to cancel the registration of a registered vehicle if—

- (a) a defect notice is issued under the Vehicle Standards and Safety Regulation for the vehicle; and
- (b) the vehicle's registered operator contravenes the requirements of the defect notice; and
- (c) the chief executive gives the registered operator a written notice (the “**warning notice**”) stating that a ground will exist to cancel the vehicle's registration under section 19¹² of the Act at the end of 14 days after the date of the warning notice if the registered operator does not, within that time—
 - (i) comply with the defect notice; or

¹² Section 19 (Procedure for amending, suspending or cancelling approvals) of the Act

*Transport Operations (Road Use
Management—Vehicle Registration) Regulation 1999*

- (ii) ask the chief executive to cancel the vehicle's registration;
and
- (d) the chief executive is satisfied that the registered operator has not complied with all the requirements of the defect notice within the 14 days mentioned in paragraph (c); and
- (e) the registered operator has not asked the chief executive to cancel the vehicle's registration.

(2) If the chief executive decides to cancel the registration under section 19(2)(c) of the Act, the chief executive must include in the written notice given under section 19(3) of the Act a requirement that the person (the **“relevant person”**) to whom the notice is directed must return the vehicle's registration label and number plates to the chief executive within 14 days after the giving of the notice (the **“return period”**).

(3) The relevant person must return the vehicle's registration label and number plates to the chief executive within the return period.

Maximum penalty—20 penalty units.

(4) However, if the registration label or a number plate has been lost, stolen or destroyed, the relevant person does not contravene subsection (3) in relation to the registration label or number plate if the relevant person, within the return period, notifies the chief executive in writing of the details of the loss, theft or destruction.

48 Cancellation of registration of vehicle or dealer plate

(1) This section applies if—

- (a) a vehicle does not conform with the requirements applying to the vehicle under a vehicle law about the construction, equipment and performance of motor vehicles; or
- (b) the registered operator of a vehicle does not comply with a notice given under section 39(9)(c); or
- (c) the registration or renewal of registration of a vehicle or dealer plate is paid for by a cheque, or by another method of payment, that is not honoured on presentation, and the chief executive has not yet received full payment for the registration or renewal; or
- (d) less than the correct amount is paid in relation to the payment for registration, or renewal of registration, of a vehicle or dealer

*Transport Operations (Road Use
Management—Vehicle Registration) Regulation 1999*

plate, and the chief executive has not yet received the unpaid amount; or

(e) a vehicle is recorded in the register as a written-off vehicle.

(2) If this section applies in relation to a vehicle, a ground exists to cancel the registration of the vehicle.

(3) If the chief executive decides to cancel the vehicle's registration under section 19(2)(c)¹³ of the Act, the chief executive must include in the written notice given under section 19(3) of the Act a requirement that the person (the **“relevant person”**) to whom the notice is directed must return the vehicle's registration label and number plates to the chief executive within 14 days after the giving of the notice (the **“return period”**).

(4) The relevant person must return the vehicle's registration label and number plates to the chief executive within the return period.

Maximum penalty—20 penalty units.

(5) However, if the registration label or a number plate has been lost, stolen or destroyed, the relevant person does not contravene subsection (4) in relation to the registration label or number plate if the relevant person, within the return period, notifies the chief executive in writing of the details of the loss, theft or destruction.

(6) If this section applies in relation to a dealer plate, a ground exists to cancel the registration of the dealer plate.

(7) If the chief executive decides to cancel the registration of the dealer plate under section 19(2)(c) of the Act, the chief executive must include in the written notice given under section 19(3) of the Act a requirement that the person (the **“dealer plate holder”**) to whom the notice is directed must return the dealer plate to the chief executive within 14 days after the giving of the notice (the **“dealer plate return period”**).

(8) The dealer plate holder must return the dealer plate to the chief executive within the dealer plate return period.

Maximum penalty—30 penalty units.

(9) However, if the dealer plate has been lost, stolen or destroyed, the dealer plate holder does not contravene subsection (8) if the dealer plate holder, within the dealer plate return period, notifies the chief executive in writing of the details of the loss, theft or destruction.

13 Section 19 (Procedure for amending, suspending or cancelling approvals) of the Act

*Transport Operations (Road Use
Management—Vehicle Registration) Regulation 1999*

(10) Nothing in this section stops the chief executive from recovering from the relevant person or dealer plate holder an amount, worked out on a proportional basis, of any amount for registration referable to the period ending on the cancellation.

(11) Section 56¹⁴ of the Act does not apply to a registration, or renewal of registration, of a vehicle or dealer plate.

49 Recording cancellation of registration in register

(1) If the chief executive cancels a vehicle's registration, the chief executive must record the cancellation in the register.

(2) If the registered operator applied for the cancellation under section 45(1)(a) or (b)(iii), the cancellation is effective on the day of receipt of the application conforming with that section.

(3) If the registered operator applied for the cancellation under section 45(1)(b)(i), the cancellation is effective on the day after the vehicle is reported as stolen to the police service.

(3A) If the registered operator applied for the cancellation under section 45(1)(b)(iv), the cancellation is effective on the day after the day the vehicle stopped being used on roads as a result of it having become a total loss.

(4) If the registered operator applied for cancellation under section 45(1)(b)(ii), the cancellation is effective on the day of receipt of the application conforming with that section.

(5) However, if on an application under subsection 45(1)(b)(ii) the chief executive is satisfied the vehicle has been registered in another State under a corresponding law to this regulation, the cancellation is taken to be effective on the day immediately after the day the vehicle was registered in the other State.

(6) If the chief executive cancels a vehicle's registration under section 45A, the cancellation is taken to be effective on the day immediately after the day the vehicle was registered in the other State.

(7) If none of subsections (2) to (6) applies, the cancellation is effective on the day the chief executive records the cancellation in the register.

14 Section 56 (Using documents voided for non-payment) of the Act

PART 7—WHEN REGISTRATION UNNECESSARY

Division 1—Unregistered vehicle permits

50 Unregistered vehicle permits

(1) The chief executive may authorise the use of an unregistered vehicle on a road by issuing an unregistered vehicle permit for the vehicle.

(2) An applicant for the permit must apply to the chief executive in the approved form, accompanied by—

- (a) the relevant fee; and
- (b) an insurance certificate under the *Motor Accident Insurance Act 1994* for the vehicle for the proposed term of the permit.

(3) The chief executive may issue the permit for the term, which must not be longer than 7 days, and on the reasonable conditions, stated in it.

(4) If the permit is issued on conditions, it is void if the conditions are contravened.

(5) A person to whom an unregistered vehicle permit is issued must ensure that, whenever the vehicle is being used under the permit on a road—

- (a) if the vehicle is a motorbike or tractor—the driver carries the permit; or
- (b) if the vehicle is a trailer—the permit is carried in the vehicle towing the trailer; or
- (c) otherwise—the permit is attached to the vehicle in the way required under section 33 as if it were a registration label.

Maximum penalty—12 penalty units.

(6) The chief executive may not issue an unregistered vehicle permit for a vehicle that does not conform with a vehicle law.

Division 2—Dealer plates

51 Designation of dealer plates

The chief executive may designate a series of number plates as dealer plates.

52 Registration of dealer plate

(1) An unregistered vehicle may be used on a road if—

- (a) a dealer plate is attached to the vehicle; and
- (b) the registration of the dealer plate is current.

(2) The chief executive must not register a dealer plate unless the chief executive is satisfied that the person in whose name the dealer plate is to be registered is a person who requires the plate for the conduct of the person's business.

(3) An applicant for a dealer plate must apply to the chief executive in the approved form, which must be accompanied by—

- (a) the relevant fee; and
- (b) an insurance certificate under the *Motor Accident Insurance Act 1994* for the proposed registration term or the insurance premium payable under that Act for the certificate.

(4) On registering the dealer plate, the chief executive must—

- (a) assign a registration number; and
- (b) record in the register the following particulars—
 - (i) the name, address and place of business of the person to whom the plate has been issued;
 - (ii) commencement and expiry days for the registration of the dealer plate; and
- (c) give the applicant—
 - (i) a registration certificate; and
 - (ii) the dealer plate; and
 - (iii) a registration label for the dealer plate.

*Transport Operations (Road Use
Management—Vehicle Registration) Regulation 1999*

(5) The registration of a dealer plate is renewable, but is not transferable.

(6) In this section—

“**unregistered vehicle**” does not include a vehicle that—

- (a) is not capable of being registered under this regulation; or
- (b) is only capable of being registered under this regulation for limited use.

53 Attaching dealer plate

(1) The person in whose name a dealer plate is registered must ensure that when an unregistered vehicle is used under the authority of the dealer plate on a road—

- (a) the registration label for the dealer plate is attached to the dealer plate; and
- (b) the dealer plate is attached to the vehicle in the way required under subsection (2).

Maximum penalty—12 penalty units.

(2) The plate must be attached to the vehicle in the way required if the dealer plate were a number plate issued for the vehicle.

(3) Subsection (1)(a) does not apply if—

- (a) fewer than 14 days have elapsed since the dealer plate was registered, or the dealer plate’s registration was renewed, in the person’s name; and
- (b) the person has not yet received the registration label from the chief executive.

54 Use of dealer plates

(1) A person must not use, or permit to be used, on a road, a vehicle with a dealer plate attached to it unless the vehicle—

- (a) is being demonstrated for its sale; or
- (b) is being delivered to a purchaser after sale; or
- (c) is travelling to or from a workshop or another facility for—
 - (i) painting, repairs or motor body construction work; or

*Transport Operations (Road Use
Management—Vehicle Registration) Regulation 1999*

- (ii) the fitting of optional equipment before delivery to a purchaser; or
- (d) is being tested after having been painted or repaired, or after having been the subject of motor body construction work; or
- (e) is being used for demonstration purposes for the conduct of an art union under the *Art Unions Act 1992*;¹⁵ or
- (f) is being used for a purpose approved by the chief executive in a written notice given to the person in whose name the dealer plate is registered.

Maximum penalty—16 penalty units.

(2) A person must not use, or permit to be used, on a road, a vehicle with a dealer plate, other than a dealer (trailer trade) plate, attached to it if the vehicle is carrying a load or towing a vehicle carrying a load, unless the vehicle with the dealer plate attached—

- (a) is a boat trailer carrying a boat; or
- (b) is towing a motor vehicle travelling on its rear wheels only, with its front portion mounted on the towing vehicle; or
- (c) is carrying the load only to demonstrate the vehicle for its sale, and not for hire or reward.

Maximum penalty—40 penalty units.

(3) A person must not use, or permit to be used, on a road, a vehicle with a dealer (trailer trade) plate attached to it unless the vehicle is—

- (a) a trailer not carrying a load; or
- (b) a boat trailer carrying a boat; or
- (c) a trailer carrying a load only to demonstrate the trailer for its sale, and not for hire or reward.

Maximum penalty—40 penalty units.

(4) A person (the “**vehicle user**”) must not use, on a road, a vehicle with a dealer plate attached to it unless the person in whose name the dealer plate is registered has authorised the vehicle user to use the dealer plate.

Maximum penalty—16 penalty units.

¹⁵ Now see *Charitable and Non-Profit Gaming Act 1999*, section 188.

(5) In this section—

“dealer (trailer trade) plate” means a dealer plate issued under this division authorising the use of an unregistered trailer on a road.

55 Cancellation of dealer plates

(1) The chief executive may cancel the registration of a dealer plate, and record the cancellation in the register, if the person in whose name the plate is registered—

- (a) applies in writing to the chief executive for the cancellation; and
- (b) unless the person has notified the chief executive in writing of details of the loss, theft or destruction of the dealer plate—returns the dealer plate to the chief executive.

(2) Subsection (3) applies if either of the following events (the **“relevant event”**) happens in relation to a person in whose name a dealer plate is registered—

- (a) the person stops carrying on the business for which the plate was registered;
- (b) there is a material change in the nature of the person’s business from that stated in the person’s application for the registration of the plate.

(3) The person must, within 14 days after the relevant event happens—

- (a) notify the chief executive in writing about the relevant event; and
- (b) return the dealer plate to the chief executive.

Maximum penalty—30 penalty units.

(4) On receiving a notification under subsection (3), the chief executive must cancel the registration of the dealer plate and record in the register the cancellation of the registration.

(5) A ground exists to cancel the registration of a dealer plate if a person required to comply with subsection (3) does not notify the chief executive under the subsection.

*Transport Operations (Road Use
Management—Vehicle Registration) Regulation 1999*

(6) If, the chief executive decides to cancel the registration of a dealer plate under section 19(2)(c)¹⁶ of the Act, the chief executive must include in the written notice given under section 19(3) of the Act a requirement that the person (the “**relevant person**”) to whom the notice is directed must, unless the relevant person has already done so, return the dealer plate to the chief executive within 14 days after the giving of the notice.

(7) The relevant person must comply with the requirement under subsection (6).

Maximum penalty—30 penalty units.

(8) If a dealer plate required to be returned under subsection (3)(b) or (7) (the “**relevant provision**”) has been lost, stolen or destroyed, the person required to return the plate does not contravene the relevant provision if the person, in the period within which the dealer plate is required to be returned, notifies the chief executive in writing of the details of the loss, theft or destruction.

(9) The cancellation of the registration of a dealer plate is effective—

- (a) for a cancellation under subsection (1)—immediately the person has complied with the subsection; or
- (b) otherwise—on the day the chief executive records the cancellation in the register.

PART 7A—WRITTEN-OFF VEHICLES

Division 1—Objects of pt 7A

55A Objects

The objects of this part include—

- (a) to provide for the collection of information about written-off vehicles; and

¹⁶ Section 19 (Procedure for amending, suspending or cancelling approvals) of the Act

*Transport Operations (Road Use
Management—Vehicle Registration) Regulation 1999*

- (b) to provide for the inspection of written-off vehicles that are repairable write-offs.

Division 2—Notifying of written-off vehicle information

55B General obligations of notifiers

(1) The chief executive may require a notifier required to give notifiable information for a written-off vehicle under this regulation to give to the chief executive information in the approved form.

(2) The information the chief executive may require under subsection (1) must be information the chief executive reasonably considers is required to maintain the integrity of information about written-off vehicles kept by the chief executive in the register.

(3) The notifier must comply with a requirement given under this section.

Maximum penalty for subsection (3)—20 penalty units.

55C Auditing of notifiers

(1) The chief executive must conduct audits of notifiers' operations as givers of notifiable information about written-off vehicles under this regulation.

(2) A notifier must allow the notifier's operations as a giver of notifiable information to be audited by the chief executive.

Maximum penalty—20 penalty units.

(3) If the report of an audit under this section identifies noncompliance with this regulation, the chief executive may, by written notice given to the notifier, require the notifier to give the chief executive, within 14 days after the date of the notice, a notice signed by the notifier stating the action the notifier has taken to do either or both of the following, as directed in the chief executive's notice—

- (a) rectify the non-compliance;
- (b) ensure that the non-compliance does not continue or happen again.

*Transport Operations (Road Use
Management—Vehicle Registration) Regulation 1999*

(4) The notifier must comply with the requirement, unless the notifier has a reasonable excuse.

Maximum penalty—20 penalty units.

(5) In a proceeding against the notifier for an offence against this regulation, other than for an offence against subsection (4), neither the notice given by the notifier, nor the fact that the notifier gave the notice, can be used in evidence against the notifier.

(6) If an audit report identifies material non-compliance with this regulation, the notifier must pay the cost of the audit and of compiling the audit report, but is not otherwise required to pay the cost.

55D Obligation of notifiers to give notifiable information

(1) A notifier must give notifiable information for a vehicle to the chief executive—

- (a) in the approved form; or
- (b) if the notifier obtains the chief executive's approval to give the notifiable information in an electronic form—in the electronic form.

(2) A notifier may change details of the notifiable information for a vehicle given to the chief executive only if—

- (a) the vehicle has not been repaired; and
- (b) the vehicle has not left the notifier's possession since the notifier gave the information to the chief executive.

(3) A notifier must not knowingly or recklessly give notifiable information for a vehicle to the chief executive that is false or misleading in a material particular.

Maximum penalty for subsection (3)—80 penalty units.

55E Obligation of insurer to report written-off vehicle

(1) This section applies if an insurer, in the course of the business carried on by the insurer in the State, and whether or not on the advice of a loss adjuster—

- (a) assesses as a total loss a notifiable vehicle registered under this regulation; or

*Transport Operations (Road Use
Management—Vehicle Registration) Regulation 1999*

- (b) assesses as a total loss a notifiable vehicle that is anywhere in Australia, but is not registered under this regulation or a corresponding law to this regulation.

(2) The insurer must give the chief executive the notifiable information for the vehicle before the first of the following happens—

- (a) 7 days elapse after the insurer makes a final decision for a claim in relation to the vehicle;
- (b) the insurer—
 - (i) disposes of the vehicle; or
 - (ii) disposes of any part of the vehicle that has a chassis number or VIN; or
 - (iii) sells the vehicle; or
 - (iv) sells any part of the vehicle that has a chassis number or VIN.

Maximum penalty for subsection (2)—50 penalty units.

55F Obligation of self-insurer to report written-off vehicle

(1) This section applies if a self-insurer—

- (a) assesses as a total loss a notifiable vehicle registered under this regulation in the name of the self-insurer; or
- (b) assesses as a total loss a notifiable vehicle that is anywhere in Australia and is owned by the self-insurer, but is not registered under this regulation or a corresponding law to this regulation.

(2) The self-insurer must give the chief executive the notifiable information for the vehicle before the first of the following happens—

- (a) 7 days elapse after making the assessment;
- (b) the self-insurer—
 - (i) disposes of the vehicle; or
 - (ii) disposes of any part of the vehicle that has a chassis number or VIN; or
 - (iii) sells the vehicle; or

*Transport Operations (Road Use
Management—Vehicle Registration) Regulation 1999*

- (iv) sells any part of the vehicle that has a chassis number or VIN.

Maximum penalty for subsection (2)—50 penalty units.

55G Obligation of loss adjuster to report written-off vehicle

(1) This section applies if a loss adjuster, acting in the course of the business carried on by the loss adjuster, but acting other than to advise an insurer, auctioneer or dealer—

- (a) assesses as a total loss a notifiable vehicle registered under this regulation; or
- (b) assesses as a total loss a notifiable vehicle that is in the State, but is not registered under this regulation or a corresponding law to this regulation.

(2) The loss adjuster must give the chief executive the notifiable information for the vehicle within 7 days after finalising the loss adjuster's assessment of the vehicle.

Maximum penalty for subsection (2)—50 penalty units.

55H Obligation of dealer or auctioneer to report written-off vehicle

(1) This section applies if a person who is a dealer or an auctioneer, in the course of the business carried on by the person, has in the person's possession—

- (a) a notifiable vehicle, registered under this regulation, that is a total loss; or
- (b) a notifiable vehicle, not registered under this regulation or a corresponding law to this regulation, that is a total loss.

(2) The person must give the chief executive the notifiable information for the vehicle before the first of the following happens—

- (a) 7 days elapse after the person takes possession of the vehicle;
- (b) the auctioneer or dealer—
 - (i) disposes of the vehicle; or
 - (ii) disposes of any part of the vehicle that has a chassis number or VIN; or

*Transport Operations (Road Use
Management—Vehicle Registration) Regulation 1999*

- (iii) sells the vehicle; or
- (iv) sells any part of the vehicle that has a chassis number or VIN.

Maximum penalty—50 penalty units.

(3) The person is not required to act under subsection (2) if someone else has already given the notifiable information for the vehicle to the chief executive.

(4) In this section—

“**possession**” includes custody or control.

55I Obligation of auto parts dismantler to report written-off vehicle

(1) This section applies if a person who is an auto parts dismantler, in the course of the business carried on by the person—

- (a) assesses as a total loss a notifiable vehicle registered under this regulation; or
- (b) assesses as a total loss a notifiable vehicle that is in the State, but is not registered under this regulation or a corresponding law to this regulation.

(2) The person must give the chief executive the notifiable information for the vehicle before the first of the following happens—

- (a) 7 days elapse after the person takes possession of the vehicle;
- (b) the person—
 - (i) demolishes or dismantles the vehicle; or
 - (ii) disposes of the vehicle; or
 - (iii) disposes of any part of the vehicle that has a chassis number or VIN; or
 - (iv) sells the vehicle; or
 - (v) sells any part of the vehicle that has a chassis number or VIN.

Maximum penalty—50 penalty units.

(3) The person is not required to act under subsection (2) if someone else has already given the information to the chief executive.

*Transport Operations (Road Use
Management—Vehicle Registration) Regulation 1999*

(4) Despite subsection (3), the person must give the chief executive the notifiable information for the vehicle on demolishing or dismantling the vehicle.

55J Obligation of registered operator or owner of unregistered vehicle to report written-off vehicle

(1) This section applies if a person, other than a self-insurer, proposes to sell or otherwise dispose of a notifiable vehicle, or a part of a notifiable vehicle that has an identifying number, and—

- (a) the vehicle is a total loss; and
- (b) either—
 - (i) the person is the registered operator of the vehicle; or
 - (ii) the vehicle is not registered under this regulation or a corresponding law to this regulation, the person is the owner of the vehicle and the vehicle is in the State.

(2) The person must give the chief executive the notifiable information for the vehicle, in the approved form, before—

- (a) disposing of the vehicle; or
- (b) disposing of any part of the vehicle that has a chassis number or VIN; or
- (c) selling the vehicle; or
- (d) selling any part of the vehicle that has a chassis number or VIN.

Maximum penalty—10 penalty units.

(3) Despite subsection (2), the person is not required to state whether the vehicle is a repairable write-off or a statutory write-off.

(4) The chief executive is taken to have been notified that the vehicle is a repairable write-off unless someone else has already—

- (a) given the notifiable information for the vehicle to the chief executive; and
- (b) stated that the vehicle is a statutory write-off.

(5) The person is not required to act under subsection (2) if someone else has already given the information to the chief executive.

*Transport Operations (Road Use
Management—Vehicle Registration) Regulation 1999*

55K Notifier's obligation to tell registered operator or owner

(1) This section applies if—

- (a) a notifier gives the notifiable information for a notifiable vehicle to the chief executive under this part; and
- (b) the notifier is not the registered operator or the owner of the vehicle.

(2) The notifier must tell the registered operator of the vehicle or, if the vehicle is not registered under this regulation or a corresponding law to this regulation, the owner of the vehicle, that the notifier has given the information to the chief executive.

Maximum penalty for subsection (2)—10 penalty units.

55L Obligation on notifiers to attach written-off vehicle label to written-off vehicle

(1) This section applies if a notifier gives notifiable information for a notifiable vehicle to the chief executive under this part.

(2) The notifier must, in accordance with subsections (3) to (6), on giving the information to the chief executive, attach to the vehicle a label that meets the chief executive's specifications for the vehicle.

Maximum penalty—30 penalty units.

(3) The label must state whether the vehicle is a repairable write-off or a statutory write-off.

(4) If the label states that the vehicle is a repairable write-off, the label must also state that a repairable write-off can be registered under this regulation only if it passes a written-off vehicle inspection.

(5) If the label states that the vehicle is a statutory write-off, the label must also state that a statutory write-off can not be registered under this regulation.

(6) The label must be attached to the vehicle in a conspicuous position so as to be clearly visible from outside the vehicle.

Examples of when a label is not attached in a conspicuous position—

- label attached to back seat
- label attached to vehicle floor.

55M Obligation on registered operator or owner to attach written-off vehicle label to written-off vehicle

(1) This section applies if the registered operator or the owner of a notifiable vehicle gives the notifiable information for the vehicle to the chief executive under this part.

(2) The registered operator or owner must, in accordance with subsection (3), attach a label in the approved form to the vehicle.

Maximum penalty—30 penalty units.

(3) The label must—

- (a) be attached to the vehicle within 24 hours after the person gives the information to the chief executive; and
- (b) be attached to the vehicle in a conspicuous position so as to be clearly visible from outside the vehicle.

Examples of when a label is not attached in a conspicuous position—

- label attached to back seat
- label attached to vehicle floor.

55N Offence to remove written-off vehicle label

A person must not remove from a vehicle a label attached to the vehicle under this part while the vehicle is recorded in the register as a written-off vehicle, unless the person has a reasonable excuse.

Maximum penalty—30 penalty units.

55O Written-off vehicles must not be used on road

(1) A person must not use, or permit to be used, on a road a vehicle that is recorded in the register, or in a register kept under a corresponding law to this regulation, as a statutory write-off.

Maximum penalty—20 penalty units.

(2) A person must not use, or permit to be used, on a road a vehicle that is—

- (a) registered under this regulation or under a corresponding law to this regulation; and

*Transport Operations (Road Use
Management—Vehicle Registration) Regulation 1999*

- (b) recorded in the register, or in a register kept under a corresponding law to this regulation, as a repairable write-off.

Maximum penalty—20 penalty units.

(3) A person does not commit an offence against subsection (2) if the vehicle is being driven or towed to—

- (a) an AIS under the Vehicle Standards and Safety Regulation for inspection for obtaining an inspection certificate under that regulation; or
- (b) a written-off vehicle inspection site for obtaining a written-off vehicle inspection report, but only if there is a current inspection certificate for the vehicle under the Vehicle Standards and Safety Regulation; or
- (c) another place as required by the chief executive.

Examples for paragraph (c)—

- A place for inspecting by the Queensland Police Service
- A place for road testing by an inspection station
- A place for having an identifying number stamped.

Division 3—Written-off vehicle inspections

55P Definition for div 3

In this division—

“approval” means an approval of a person as—

- (a) an approved written-off vehicle examiner; or
- (b) an approved written-off vehicle nominee.

55Q Approvals

(1) The chief executive may grant a person an approval.

(2) A person may apply to the chief executive in the approved form for an approval.

(3) The chief executive must consider an application for an approval within 28 days after it is received and decide either to—

*Transport Operations (Road Use
Management—Vehicle Registration) Regulation 1999*

- (a) grant the approval; or
- (b) refuse to grant the approval.

(4) If the chief executive decides an applicant is a suitable person for an approval, the chief executive must, promptly after making the decision, grant the approval.

55R Conditions of approval

An approval may be granted subject to conditions, including—

- (a) for an approval of a person as an approved written-off vehicle examiner—
 - (i) a condition that the approved written-off vehicle examiner may only perform written-off vehicle inspections while employed or otherwise engaged by an entity contracted by the chief executive to operate a written-off vehicle inspection site; and
 - (ii) conditions about the way the approved written-off vehicle examiner is to perform written-off vehicle inspections; or
- (b) for an approval of a person as an approved written-off vehicle nominee—
 - (i) a condition that the approved written-off vehicle nominee may only supervise the day to day running of written-off vehicle inspections while employed or otherwise engaged by an entity contracted by the chief executive to operate a written-off vehicle inspection site; and
 - (ii) conditions about the way the approved written-off vehicle nominee is to supervise the day to day running of written-off vehicle inspections.

55S Refusing to grant approval

(1) If the chief executive decides to refuse to grant the approval, the chief executive must give written notice to the applicant of the decision promptly after making the decision.

(2) The notice must state—

- (a) the reasons for the refusal; and

*Transport Operations (Road Use
Management—Vehicle Registration) Regulation 1999*

- (b) that the person may ask for the decision to be reviewed under section 66.

55T Approval prescribed for the Act, ss 17B(2) and 18(c)(ii)

An approval under this division is prescribed for sections 17B(2) and 18(c)(ii)¹⁷ of the Act.

Division 4—Offences relating to written-off vehicle inspections

55U Performing written-off vehicle inspection when not approved

A person must not perform, or purport to perform, a written-off vehicle inspection unless the person is an approved written-off vehicle examiner.

Maximum penalty—80 penalty units.

55V Supervising written-off vehicle inspections when not approved

A person must not supervise, or purport to supervise, the running of written-off vehicle inspections unless the person is an approved written-off vehicle nominee.

Maximum penalty—80 penalty units.

55W Not complying with conditions of approval

A person holding an approval must comply with all conditions stated in the approval.

Maximum penalty—80 penalty units.

¹⁷ Sections 17B (Granting, renewing or refusing approval) and 18 (Grounds for amending, suspending or cancelling approvals) of the Act

55X False or misleading written-off vehicle inspection report

A person must not knowingly or recklessly give a written-off vehicle inspection report to another person that is false or misleading in a material particular.

Maximum penalty—80 penalty units.

55Y Operating place as a written-off vehicle inspection site

A person must not operate, or purport to operate, a place as a written-off vehicle inspection site unless the person is contracted by the chief executive to operate the place as a written-off vehicle inspection site.

Maximum penalty—80 penalty units.

55Z Performing written-off vehicle inspection at place other than written-off vehicle inspection site

An approved written-off vehicle examiner must not perform a written-off vehicle inspection at a place other than a place operated by a person contracted by the chief executive to operate the place as a written-off vehicle inspection site.

Maximum penalty—80 penalty units.

55ZA Supervising written-off vehicle inspections at place other than written-off vehicle inspection site

An approved written-off vehicle nominee must not supervise the running of written-off vehicle inspections at a place other than a place operated by a person contracted by the chief executive to operate the place as a written-off vehicle inspection site.

Maximum penalty—80 penalty units.

55ZB False advertising or holding out

A person must not falsely advertise or hold out that a particular place is a place where written-off vehicle inspections may be performed.

Maximum penalty—80 penalty units.

PART 8—GENERAL

Division 1—Other provisions about number plates and other items

56 Replacement registration items

(1) This section applies if a registration item for a registered vehicle has been damaged, destroyed, lost or stolen.

(2) The registered operator of the vehicle must apply to the chief executive in writing for a replacement item within 14 days after discovering the item has been damaged, destroyed, lost or stolen.

Maximum penalty—6 penalty units.

(3) An application for a replacement number plate must be accompanied by—

- (a) the relevant plate fee; and
- (b) either—
 - (i) for the replacement of a damaged number plate—the damaged number plate; or
 - (ii) for the replacement of a destroyed, lost or stolen number plate—a written statement giving details of the loss, theft or destruction.

(4) On receipt of the application, the chief executive may—

- (a) record in the register—
 - (i) the day the application was received; and
 - (ii) the damage, destruction, loss or theft of the item; and
- (b) issue a replacement or updated registration item.

(5) If the application is for the replacement of a number plate, until the replacement number plate is issued, the registered operator must attach any remaining plate to the rear of the vehicle.

Maximum penalty—12 penalty units.

(6) The registration item being replaced ceases to be effective on the issue of the replacement registration item, and the replacement registration item becomes the current registration label or number plate for the vehicle.

*Transport Operations (Road Use
Management—Vehicle Registration) Regulation 1999*

(7) The person must immediately return to the chief executive an item that was a registration item if the person recovers the item after the chief executive has issued a replacement item for it.

Maximum penalty—20 penalty units.

(8) In this section—

“registration item” means—

- (a) a current registration label; or
- (b) a number plate.

57 Chief executive may require exchange of number plates

(1) This section applies if the chief executive—

- (a) considers the number displayed on a number plate for a vehicle is obscene or indecent; or
- (b) changes the specifications to which a number plate for a vehicle is manufactured.

(2) The chief executive may, by written notice given to the registered operator of the vehicle, require the registered operator to return the number plate to the chief executive within the time stated in the notice to be exchanged for another number plate.

(3) The notice must state the chief executive’s reason for requiring the return of the original plate.

(4) The registered operator must not contravene the requirement unless the person has notified the chief executive in writing that the original plate has been lost, stolen or destroyed.

Maximum penalty—20 penalty units.

(5) The chief executive must record the exchange of the plate in the register.

58 Chief executive may require return of number plates

(1) This section applies if the chief executive reasonably believes—

- (a) a number plate is being used, or has been used, in contravention of this regulation; or

*Transport Operations (Road Use
Management—Vehicle Registration) Regulation 1999*

- (b) a number plate was issued as the number plate for a limousine or taxi and the limousine or taxi is no longer operating under the licence issued under the *Transport Operations (Passenger Transport) Act 1994*.

(2) The chief executive may, by written notice, require the person to whom the number plate was issued to return the plate to the chief executive within 14 days of the date of the notice (the “**return period**”).

(3) The person must return the number plate to the chief executive within the return period.

Maximum penalty—20 penalty units.

(4) However, if the number plate has been lost, stolen or destroyed, the person does not contravene subsection (3) if the person, within the return period, notifies the chief executive in writing of the details of the loss, theft or destruction.

(5) The chief executive must record the return of the number plate in the register.

(6) If this section applies because of subsection (1)(b)—

- (a) the chief executive may, in the written notice given to a person under subsection (2), also require that the number plate, when returned, be exchanged for a new number plate; and
- (b) if the number plate is not returned within the return period, the chief executive may issue a replacement number plate for the limousine or taxi.

(7) The number plate being replaced ceases to be effective on the issue of the replacement number plate, and the replacement number plate becomes the current number plate for the vehicle.

59 Property in number plates

(1) A number plate issued by the chief executive remains the property of the State.

(2) Subsection (1) applies even if the right to use the number in the number plate is the property of the person to whom the plate was issued.

Division 2—Vehicles temporarily in Queensland

60 Vehicles temporarily in Queensland

- (1) This section applies to a vehicle if the vehicle—
- (a) does not have a garage address in Queensland or has had a garage address in Queensland for not more than 14 days; and
 - (b) is to be used on a road; and
 - (c) either—
 - (i) the vehicle is registered in—
 - (A) another State under a corresponding law to this regulation; or
 - (B) a foreign country under a law of the country about the registration of vehicles used on roads; or
 - (ii) the vehicle is not registered in a way mentioned in subparagraph (i), but may be used on a road under an authority or permit in force under a law of another State relating to the use of unregistered vehicles, including a law relating to dealer plates.
- (2) The vehicle may be used on a road if—
- (a) the vehicle carries and displays all number plates and registration labels it is required to carry and display in the way required by the law—
 - (i) for a vehicle mentioned in subsection (1)(c)(i)—of the other State or foreign country; or
 - (ii) for a vehicle mentioned in subsection (1)(c)(ii)—of the other State; and
 - (b) for a vehicle mentioned in subsection (1)(c)(ii)—the vehicle is used in accordance with the relevant authority or permit, so far as it is capable of being applied to the use of the vehicle outside the other State; and
 - (c) the vehicle is insured—
 - (i) for a vehicle registered in a foreign country—under the *Motor Accident Insurance Act 1994*; or

*Transport Operations (Road Use
Management—Vehicle Registration) Regulation 1999*

- (ii) for a vehicle registered in, or used under an approval issued by, another State—under a contract of insurance made under a law of the State similar to the *Motor Accident Insurance Act 1994*.

(3) The owner or person in charge of the vehicle must ensure that when the vehicle is used on a road the owner or person is able to produce for inspection on demand by an authorised officer—

- (a) for a vehicle registered in a foreign country—an overseas vehicle permit issued under subsection (6); or
- (b) otherwise—the approval to use the vehicle under the law of the other State.

Maximum penalty—8 penalty units.

(4) If the vehicle is a vehicle mentioned in subsection (1)(c)(i)(B), an owner or person in charge of the vehicle who is temporarily in Australia may apply to the chief executive for an overseas vehicle permit for the vehicle.

(5) The application must be in the approved form and accompanied by the relevant fee.

(6) The chief executive may issue the permit only if the owner or person satisfies the chief executive that—

- (a) the vehicle is—
 - (i) registered in a foreign country; and
 - (ii) temporarily in Queensland; and
- (b) the owner or person has insured the vehicle under subsection (2)(c)(i) and will continue to comply with subsection (2)(a)(i).

(7) A category 2 vehicle's garage address is taken to be an address in Queensland if the vehicle is used continuously in Queensland for more than 3 months.

Division 3—Other miscellaneous provisions

61 Sale of unregistered vehicles by dealers

(1) A dealer must not deliver an unregistered vehicle to a purchaser, other than another dealer, on the sale of the vehicle unless an application to register the vehicle under this regulation has been made.

Maximum penalty—40 penalty units.

(2) However, the dealer does not contravene subsection (1) if the dealer obtains a written statement from the purchaser that—

- (a) the vehicle is not to be used on a road; or
- (b) the vehicle's garage address will not be in Queensland.

(3) If the vehicle is delivered under subsection (2), the dealer must keep the statement for at least 1 year after the day of delivery of the vehicle to the purchaser.

Maximum penalty—8 penalty units.

62 Authorisation to use unregistered vehicle on roads

(1) A person may apply in writing to the chief executive for an authorisation to use on a road an unregistered vehicle, or class of unregistered vehicle, including a vehicle or class of vehicle that does not conform with the requirements applying to the vehicle or class under a vehicle law.

(2) The chief executive may grant the authorisation only if the chief executive is satisfied the use of the vehicle, or class of vehicle, on the road would not—

- (a) adversely affect road safety; or
- (b) inconvenience other road users.

(3) Before granting the authorisation, or as a condition of it, the chief executive may require the applicant to pay the chief executive's costs or estimated costs of the following—

- (a) assessing the vehicle's route and preparing the relevant plans and estimates;

*Transport Operations (Road Use
Management—Vehicle Registration) Regulation 1999*

- (b) preparing and strengthening road transport infrastructure on the route;
- (c) repairing, replacing or reconstructing road transport infrastructure on the route;
- (d) ensuring compliance with a condition or a proposed condition of the authorisation.

(4) The authorisation must be in writing and state the following particulars—

- (a) the vehicle or the class of vehicles to which it applies;
- (b) the roads where the vehicle may be used;
- (c) the term, not longer than 5 years, for which it is issued;
- (d) the conditions, if any, on which it is issued.

(5) If the authorisation is issued on conditions, it is void if the conditions are contravened.

63 Permit to use intercepted unregistered vehicle on road

(1) This section applies if an authorised officer finds on a road—

- (a) a stationary unregistered vehicle; or
- (b) an unregistered vehicle that has been stopped under—
 - (i) section 31 or 32¹⁸ of the Act; or
 - (ii) the *Police Powers and Responsibilities Act 1997*.¹⁹

(2) The authorised officer may issue a permit authorising the use of the vehicle on roads to move it to a stated place if the officer has—

- (a) issued an infringement notice under the *Justices Act 1886* for a contravention of section 10;²⁰ or
- (b) completed a report for dealing with the contravention at a later time.

18 Section 31 (Power to stop private vehicles) or 32 (Power to stop heavy vehicles) of the Act

19 Now see *Acts Interpretation Act 1954*, section 14H and *Police Powers and Responsibilities Act 2000*, section 51.

20 Section 10 (Vehicles used on roads must be registered)

*Transport Operations (Road Use
Management—Vehicle Registration) Regulation 1999*

(3) The permit must—

- (a) be in the approved form; and
- (b) state the term, not longer than 24 hours, for which it is issued; and
- (c) state the conditions, if any, on which it is issued; and
- (d) state—
 - (i) if subsection (2)(a) applies—the number of the infringement notice; or
 - (ii) if subsection (2)(b) applies—that the contravention of section 10 is to be dealt with at a later time either by issuing an infringement notice under the *Justices Act 1886* or by taking a proceeding by complaint and summons under that Act.

(4) If the permit is issued on a condition, it is void if the condition is contravened.

64 Damaged or dirty number plates

(1) This section applies if a vehicle's number plate is—

- (a) damaged and not legible; or
- (b) dirty and not legible.

(2) An authorised officer may, by written notice given to the registered operator of the vehicle, or to a person in charge of the vehicle, require the registered operator to—

- (a) for a damaged number plate—apply to the chief executive, within the time stated in the notice, for a replacement number plate under section 56; or
- (b) for a dirty number plate—
 - (i) clean the number plate; and
 - (ii) bring the vehicle to the chief executive to be inspected, within the time stated in the notice.

(3) If the person to whom the notice is given is not the registered operator of the vehicle, the person to whom the notice is given must

*Transport Operations (Road Use
Management—Vehicle Registration) Regulation 1999*

immediately give the notice to the registered operator of the vehicle, unless the person has a reasonable excuse.

Maximum penalty—6 penalty units.

(4) The registered operator must not contravene a requirement under subsection (2) unless the registered operator has a reasonable excuse.

Maximum penalty—6 penalty units.

(5) Despite anything else in this regulation a person who uses, or permits to be used, a vehicle on a road when a number plate required under this regulation to be attached to the vehicle is not attached to the vehicle does not commit an offence if—

- (a) the number plate is damaged; and
- (b) an authorised officer, acting under subsection (2)(a), has given the registered operator of the vehicle a written notice directing the registered operator to apply to the chief executive for a replacement number plate under section 56; and
- (c) the damaged number plate and the written notice are being carried in the vehicle; and
- (d) the vehicle is being driven to a place for the purpose of applying, at the place, to the chief executive for a replacement number plate under section 56.

Division 4—Review of decisions

65 Decision to which this division applies

(1) This division applies to a decision of the chief executive made under this regulation if the decision is one of the following—

- (a) a decision not to register a vehicle, other than a vehicle that is a statutory write-off;
- (b) a decision not to renew the registration of a vehicle, other than a vehicle that is a statutory write-off;
- (c) a decision not to register the transfer of the registration of a vehicle;
- (d) a decision not to authorise the use of a vehicle on a road under an unregistered vehicle permit;

*Transport Operations (Road Use
Management—Vehicle Registration) Regulation 1999*

- (e) a decision to refuse an overseas vehicle permit for a vehicle;
- (f) a decision to refuse to grant an approval to a person under part 7A, division 3.

(2) This division also applies to a decision of the chief executive made under this regulation if the decision is to refuse an authorisation under section 62 to use on a road a vehicle or a class of vehicles.

66 Review of decisions

(1) A person whose interests are affected by a decision to which this division applies may apply, under chapter 4 of the Act, for a review of decision as if the decision were stated in schedule 3 of the Act.

(2) The person is entitled to receive a statement of reasons for the decision.

(3) The person may appeal against a reviewed decision to a Magistrates Court.

(4) Chapter 4 of the Act applies to a review and an appeal under this section.

Division 5—Release of information

67 Definitions for div 5

In this division—

“client user”, of a public access provider, means a lawyer, insurance company, insolvency entity or statutory entity—

- (a) who has entered into a public access agreement with a public access provider; and
- (b) who has been approved by the chief executive, before or after the commencement of this section, as a suitable entity to obtain extracts from the register of information about vehicles, using on-line computer access; and
- (c) whose approval as a suitable entity has not been withdrawn.

“eligible person” means—

- (a) an involved person; or

*Transport Operations (Road Use
Management—Vehicle Registration) Regulation 1999*

- (b) a statutory entity; or
- (c) the registered operator of a vehicle seeking information from the register about the vehicle; or
- (d) a safety recall agency; or
- (e) a person seeking information from the register about a vehicle with the written consent of the registered operator of the vehicle.

“insolvency entity” means an entity exercising powers—

- (a) under the *Bankruptcy Act 1966* (Cwlth) in relation to bankruptcy; or
- (b) under the provisions of the Corporations Law relating to external administration.

“involved person” means a person who proposes to commence, or has commenced, litigation.

“litigation” means a proceeding, or a proposed proceeding, in a court for which information in the register about a particular vehicle is, or may be, of relevance, but only if—

- (a) the proceeding is about—
 - (i) an incident on a road or somewhere else involving the vehicle; or
 - (ii) the bankruptcy or possible bankruptcy of the registered operator of the vehicle, or the application, or the possible application, to the registered operator of the vehicle, of the provisions of the Corporations Law relating to external administration; or
 - (iii) fraudulent activities of the registered operator of the vehicle; or
- (b) the proceeding is before the Family Court of Australia and involves the registered operator of the vehicle; or
- (c) in the course of the proceeding, the court decides information about the registered operator of the vehicle is required, including, for example, to help to finalise the proceeding.

“personal information”, about a vehicle’s current or previous registered operator, means—

- (a) the person’s name and address; and

*Transport Operations (Road Use
Management—Vehicle Registration) Regulation 1999*

(b) any information that may identify the person.

“public access provider” means—

- (a) the chief executive; or
- (b) a person who has entered into an agreement with the chief executive to provide on-line computer access to the register to entities approved by the chief executive.

“safety recall agency” means a vehicle manufacturer conducting a national vehicle safety recall program who requires details from the register to identify the registered operators of particular vehicles.

“statutory entity” means—

- (a) a local government or other entity established under a statute enforcing a law about vehicles or about the parking of vehicles in an area under its control; or
- (b) an entity having lawful access, under another Act, or under administrative arrangements approved by the chief executive, to details kept by the chief executive in the register.

“vehicle related information”, about a vehicle, means information about the vehicle from the register, but does not include—

- (a) for a vehicle currently recorded in the register as a written-off vehicle—
 - (i) personal information about any current or previous registered operator of the vehicle; or
 - (ii) information about a notifier that has given notifiable information for the vehicle; or
 - (iii) information about the location and severity of the damage to the vehicle; or
- (b) for a vehicle that is not currently recorded in the register as a written-off vehicle—
 - (i) personal information about any current or previous registered operator of the vehicle; or
 - (ii) any written-off vehicle information about the vehicle.

“vehicle related information provider” means—

- (a) the chief executive; or

*Transport Operations (Road Use
Management—Vehicle Registration) Regulation 1999*

- (b) a person who has entered into an agreement with the chief executive to provide on-line computer or telephone access to vehicle related information to another person.

“written-off vehicle information”, about a vehicle, means all information about the vehicle that has at any time been recorded in the register for the purpose of recording information about a written-off vehicle.

68 Release of information on payment of fee

(1) The chief executive may, in the circumstances approved by the chief executive, give an extract from the register of information about a vehicle to an eligible person, or a person acting on the eligible person’s behalf, if the eligible person, or the person acting on the eligible person’s behalf—

- (a) submits a request for the information to the chief executive in the approved form; and
- (b) pays the relevant fee.

(2) The eligible person, or the person acting on the eligible person’s behalf, must not use or disclose information obtained under subsection (1) other than in accordance with conditions approved by the chief executive for the use and disclosure of the information and advised to the eligible person or the person acting on the eligible person’s behalf when, or before, the information is obtained.

Maximum penalty—20 penalty units.

(3) A public access provider may allow a client user of the provider to obtain an extract from the register of information about a vehicle, using on-line computer access, if the client user—

- (a) pays the public access provider the relevant fee; and
- (b) obtains the extract only in the circumstances approved by the chief executive for obtaining the extract.

(4) The client user must not use or disclose information obtained under subsection (3) other than in accordance with conditions approved by the chief executive for the use and disclosure of the information and advised to the client user when, or before, the information is obtained.

Maximum penalty—20 penalty units.

*Transport Operations (Road Use
Management—Vehicle Registration) Regulation 1999*

68A Release of vehicle related information on payment of a fee

(1) A vehicle related information provider may allow a person to obtain vehicle related information about a vehicle from the register, using on-line computer or telephone access, if the person—

- (a) pays the vehicle related information provider an amount decided by the chief executive; and
- (b) obtains the information only in the circumstances approved by the chief executive for obtaining the information.

(2) The person must not use or disclose information obtained under subsection (1) other than in accordance with conditions approved by the chief executive for the use and disclosure of the information and advised to the person when, or before, the information is obtained.

Maximum penalty for subsection (2)—20 penalty units.

(3) Despite subsection (1), a person must not ask the chief executive for vehicle related information about a vehicle recorded in the register as a written-off vehicle.

(4) Subsection (3) does not stop a person from asking for the information from a person delegated by the chief executive to give the information.

PART 9—FEES

Division 1—General

69 Fees

(1) The registration fees payable for a category 1 vehicle are stated in schedule 1.

(2) The registration fees payable for a category 2 vehicle are stated in schedule 2.

(3) Other fees payable under this regulation are stated in schedule 3.

(4) The fees payable under schedules 1 to 3 for vehicle registration for a term less than 1 year are to be adjusted in proportion to the number of days in the term.

*Transport Operations (Road Use
Management—Vehicle Registration) Regulation 1999*

70 Charging categories

(1) If a category 2 vehicle falls within 2 or more categories in schedule 2, the registration fee for the vehicle is the higher or highest of the fees that could apply to the vehicle.

(2) To decide the number of trailers a prime mover or truck may tow—

- (a) a dolly and a semitrailer, when used together, are taken to be 1 trailer; and
- (b) a low loader and low loader dolly, when used together, are taken to be 1 trailer.

(3) If a category 2 vehicle is registered according to a particular type in schedule 2, a person must not use the vehicle, or, whether or not the person is the vehicle's registered operator, permit another person to use the vehicle, as a vehicle of another type to which a higher registration fee applies.

Maximum penalty—80 penalty units.

Example of subsection (3)—

If a vehicle is not registered to tow a trailer, the vehicle cannot be used to haul a trailer unless its registration is changed and the relevant registration fee is paid.

(4) For applying schedule 2—

- (a) 2 axles with less than 1 m between them are taken to be 1 axle; and
- (b) 3 axles with not more than 2 m between the first and third axles are taken to be 2 axles; and
- (c) 4 axles with not more than 3.2 m between the first and fourth axles are taken to be 3 axles.

(5) For applying subsection (4) in relation to a vehicle, the distance between axles is measured between the centres of the wheels—

- (a) mounted on the axles; and
- (b) parallel to the length of the vehicle.

Division 2—Vehicles exempted from registration fees

71 Exemption from payment of fee

(1) The chief executive may grant an exemption from the payment of the registration fees otherwise payable for the registration of the following vehicles—

- (a) a vehicle owned by an association established solely for a charitable purpose within the meaning of the *Collections Act 1966* and used solely for the purpose;
- (b) a vehicle owned by—
 - (i) a consulate; or
 - (ii) the head of a consulate; or
 - (iii) a career officer of a consulate; or
 - (iv) the head of an honorary consular mission;
- (c) a motorised invalid chair used by a disabled person.

(2) An exemption under subsection (1)(b) may be granted only with the approval of the chief executive of the department within which the *Public Service Act 1996* is administered.

(3) The owner of the vehicle must apply for the exemption in the approved form.

(4) A person who is granted an exemption from the payment of the registration fee for a vehicle must notify the chief executive in writing—

- (a) before using the vehicle for a purpose other than the purpose for which the exemption was granted; or
- (b) within 14 days—
 - (i) after a material change in the circumstances under which the exemption was granted; or
 - (ii) of the sale or other transfer of the vehicle.

Maximum penalty—20 penalty units.

(5) On receipt of the notice, the chief executive may reassess the registration fee payable for the vehicle's registration, without the exemption, for the term (the "**unexpired term**")—

*Transport Operations (Road Use
Management—Vehicle Registration) Regulation 1999*

- from when the registered operator or vehicle ceased to be eligible for the exemption
- to the end of the vehicle's current registration.

(6) The chief executive may, by written notice, require the amount of the reassessed fee for the unexpired term to be paid by—

- (a) if the notice is given under subsection (4)(a) or (b)(i)—the person to whom the exemption was granted; or
- (b) if the notice is given under subsection (4)(b)(ii)—the person to whom the vehicle is sold or otherwise transferred.

(7) The person to whom the notice is directed must, within 28 days after the chief executive gives the notice, pay the amount assessed.

Maximum penalty—60 penalty units.

Division 3—Concessional registration fees for certain category 1 vehicles

72 Concessional registration fees—category 1 vehicles

(1) The chief executive may grant the registered operator of a vehicle mentioned in schedule 1, part 2, a concessional registration fee for the vehicle.

(2) An application for the concession must be in the approved form.

(3) A person who is granted a concessional registration for a vehicle must notify the chief executive in writing—

- (a) before using the vehicle for a purpose other than the purpose for which the concession was granted; or
- (b) within 14 days—
 - (i) after a material change in the circumstances under which the concession was granted; or
 - (ii) of the sale or other transfer of the vehicle.

Maximum penalty—20 penalty units.

(4) On receipt of the notice, the chief executive may reassess the registration fee payable for the vehicle's registration, without the concession, for the term (the “**unexpired term**”)—

*Transport Operations (Road Use
Management—Vehicle Registration) Regulation 1999*

- from when the registered operator or vehicle ceased to be eligible for the concession
- to the end of the vehicle's current registration.

(5) The chief executive may, by written notice, require the amount of the reassessed fee for the unexpired term to be paid by—

- (a) if the notice is given under subsection (3)(a) or (b)(i)—the person to whom the concession was granted; or
- (b) if the notice is given under subsection (3)(b)(ii)—the person to whom the vehicle is sold or otherwise transferred.

(6) The person to whom the notice is directed must, within 28 days after the chief executive gives the notice, pay the amount assessed.

Maximum penalty—20 penalty units.

Division 4—Concessional registration fees for category 2 vehicles

73 Concessional registration fees—primary producers

(1) The chief executive may grant a primary producer the concessional registration fee provided for in schedule 2, part 2 for the registration of a primary production vehicle.

(2) An application for the concession must be in the approved form.

(3) A primary producer who is granted concessional registration for a primary production vehicle must give the chief executive written notice—

- (a) before the primary producer starts to use the vehicle other than for carrying on the producer's business as a primary producer; or
- (b) within 14 days of the sale or other transfer of the vehicle.

Maximum penalty—60 penalty units.

(4) On receipt of the notice, the chief executive may reassess the registration fee payable for the vehicle's registration, without the concession, for the term (the "**unexpired term**")—

- from when the primary producer ceased to be eligible for the concession
- to the end of the vehicle's current registration.

*Transport Operations (Road Use
Management—Vehicle Registration) Regulation 1999*

(5) The chief executive may, by written notice, require any amount by which the reassessed fee is more than the fee already paid for the unexpired term to be paid by—

- (a) if the primary producer's notice is given under subsection (3)(a)—the primary producer; or
- (b) if the primary producer's notice is given under subsection (3)(b)—the person to whom the vehicle is sold or otherwise transferred.

(6) The person to whom the notice is directed must, within 28 days after the chief executive gives the notice, pay the amount assessed.

Maximum penalty—60 penalty units.

74 Concessional registration fee for motorised caravan for card holders

(1) The chief executive may grant a card holder a concessional registration fee provided for in schedule 2, part 2 for the registration of a motorised caravan owned by the person.

(2) An application for the concession must be in the approved form.

(3) A person who is granted a concessional registration as a card holder for a motorised caravan must give the chief executive written notice—

- (a) of ceasing to be a card holder, within 14 days after the cessation; or
- (b) of the sale or other transfer of the caravan within 14 days after the sale or other transfer.

Maximum penalty—20 penalty units.

(4) On receipt of the notice, the chief executive may reassess the registration fee payable for the caravan's registration, without the concession, for the term (the "**unexpired term**")—

- from when the person ceased to be eligible for the concession
- to the end of the caravan's current registration.

(5) The chief executive may, by written notice, require any amount by which the reassessed fee is more than the fee already paid for the unexpired term to be paid by—

*Transport Operations (Road Use
Management—Vehicle Registration) Regulation 1999*

- (a) if the person's notice is given under subsection (3)(a)—the person; or
- (b) if the person's notice is given under subsection (3)(b)—the person to whom the caravan is sold or otherwise transferred.

(6) The person to whom the notice is directed must, within 28 days after the chief executive gives the notice, pay the amount assessed.

Maximum penalty—20 penalty units.

75 Concessional registration fees for other vehicles

(1) The chief executive may grant a person, other than a primary producer or card holder, a concessional registration fee provided for in schedule 2, part 2 for the registration of a vehicle.

(2) An application for the concession must be in the approved form.

(3) A person who is granted a concessional registration fee for a vehicle must give the chief executive written notice—

- (a) of ceasing to be eligible for the concession, within 14 days of the cessation; or
- (b) of the sale or other transfer of the vehicle within 14 days of the sale or other transfer.

Maximum penalty—60 penalty units.

(4) On receipt of the notice, the chief executive may reassess the registration fee payable for the vehicle's registration, without the concession, for the term (the "**unexpired term**")—

- from when the person ceased to be eligible for the concession
- to the end of the vehicle's current registration.

(5) The chief executive may, by written notice, require any amount by which the reassessed fee is more than the fee already paid for the unexpired term to be paid by—

- (a) if the person's notice is given under subsection (3)(a)—the person; or
- (b) if the person's notice is given under subsection (3)(b)—the person to whom the vehicle is sold or otherwise transferred.

(6) The person to whom the notice is directed must, within 28 days after the chief executive gives the notice, pay the amount assessed.

Maximum penalty—60 penalty units.

PART 10—OTHER OFFENCE PROVISIONS

76 Offences involving registration certificates etc

(1) A person must not, unless the person has a reasonable excuse—

- (a) make, sell or have in the person's possession anything that purports to be, but is not, a registration certificate, registration label, number plate or permit; or
- (b) alter or deface a registration certificate, registration label, number plate or permit.

Maximum penalty—40 penalty units.

(2) A person must not, unless the person has a reasonable excuse, use, or permit to be used, on a road, a vehicle if—

- (a) a registration certificate, registration label, number plate or permit for the vehicle has been unlawfully altered; or
- (b) a registration certificate, registration label, number plate or permit for the vehicle has been defaced; or
- (c) a reflectorised number plate for the vehicle has been repainted in any way, for example, to repair stone chips or other damage; or
- (d) any writing, mark, or colour on a registration certificate, registration label, number plate or permit for the vehicle is not clearly legible; or
- (e) a registration label, number plate or permit attached to the vehicle was issued for another vehicle; or
- (f) a registration label or number plate attached to the vehicle has been recorded in the register as having been cancelled, lost, stolen, destroyed or damaged; or
- (g) a registration label, number plate or permit required under this regulation to be attached to the vehicle—

*Transport Operations (Road Use
Management—Vehicle Registration) Regulation 1999*

- (i) is not attached to the vehicle; or
- (ii) is attached to the vehicle, but not in the way required under this regulation; or
- (h) a registration label still attached to the vehicle should have been taken off the vehicle under section 33(7); or
- (i) a permit required under section 50(5)(a) to be carried by the driver of the vehicle is not being carried by the driver of the vehicle; or
- (j) a permit required under section 50(5)(b) to be carried in the vehicle is not being carried in the vehicle.

Maximum penalty—16 penalty units.

(3) In this section a reference to a registration certificate, registration label, number plate or permit is a reference to a registration certificate, registration label, number plate or permit issued—

- (a) by the chief executive under this regulation; or
- (b) under a corresponding law to this regulation; or
- (c) under a law of a foreign country about the registration of vehicles.

77 Requirement to remove unlawful registration item

(1) An authorised officer may require a person in charge of a vehicle to take a registration item from the vehicle, and to deliver it to the authorised officer, if the authorised officer believes on reasonable grounds that—

- (a) under this regulation, the use of the vehicle on a road is prohibited; or
- (b) the registration item was not lawfully issued for the vehicle; or
- (c) the registration item is recorded in the register as having been cancelled, lost, stolen, destroyed or damaged.

(2) The person must not contravene the requirement unless the person has a reasonable excuse.

Maximum penalty—16 penalty units.

(3) In this section—

“registration item” means—

*Transport Operations (Road Use
Management—Vehicle Registration) Regulation 1999*

- (a) a registration certificate, registration label, number plate, permit or similar item; or
- (b) an item purporting to be an item mentioned in paragraph (a).

PART 11—TRANSITIONAL PROVISIONS

Division 1—Transitional provisions for Transport Operations (Road Use Management—Vehicle Registration) Regulation 1999

78 Purpose of pt 11

This part provides for the transition from the former regulation to this regulation.

79 Definition for pt 11

In this part—

“**former regulation**” means the *Transport Infrastructure (Roads) Regulation 1991* in force immediately before its expiry under section 93A of the Act.

80 Continuation of registration and other authorities under former regulation

(1) A vehicle that is registered under the former regulation immediately before the commencement of this section is taken to be registered under this regulation for the unexpired term of its registration under the former regulation, unless the registration is sooner cancelled under this regulation.

(2) On the commencement of this section, a number plate, registration certificate or registration label that was issued for a vehicle that is registered under the former regulation immediately before the commencement of this section and that is current immediately before the commencement of this section is taken to be a current number plate, certificate or label for the vehicle under this regulation.

*Transport Operations (Road Use
Management—Vehicle Registration) Regulation 1999*

(3) A limited use permit issued for a vehicle under section 34 of the former regulation and current immediately before the commencement of this section continues, for the unexpired term of the permit, to have effect as an unregistered vehicle permit issued for the vehicle under section 50.

(4) An approval issued for a vehicle under section 44 of the former regulation and current immediately before the commencement of this section continues, for the unexpired term of the approval, to have effect as an authorisation issued for the vehicle under section 62.

(5) A permit issued for a vehicle under section 44A of the former regulation and current immediately before the commencement of this section continues, for the unexpired term of the permit, to have effect as a permit issued for the vehicle under section 63.

81 Postponement of particular changes until 31 December 1999

Until the end of 31 December 1999—

- (a) the following vehicles are taken to be included in the list of vehicles that are exempt vehicles under section 4—
 - (i) all agricultural machines;
 - (ii) all items of equipment used for the construction of works for, or maintenance of, road transport infrastructure;
 - (iii) all fire engines;
 - (iv) all motorised golf buggies; and
- (b) despite the expiry of the former regulation, the supply of extracts from the register is to continue to happen under the following provisions of the former regulation as if the regulation had not expired—
 - (i) section 13(3);
 - (ii) schedule 1, part 4, items 2 to 4.

82 Limited use plates under former regulation

(1) This section applies to a vehicle that, immediately before the commencement of this section, is the subject of a current authorisation under section 35 of the former regulation for the use of the vehicle on a road on the basis of the issue of a limited use plate.

(2) Section 35 of the former regulation, together with any other provisions of the former regulation necessary for giving section 35 continued effect, continues to apply to the vehicle until the expiry of the term for which the limited use plate was issued.

83 Position for attaching registration label to certain trailers

Section 33 does not apply to a trailer that is a category 2 vehicle in relation to a registration label attached under section 22 of the former regulation before the commencement of this section.

Division 2—Transitional provision for written-off vehicle amendments

84 Registration of vehicle recorded as a written-off vehicle under corresponding law

(1) This section applies if—

- (a) immediately before the commencement of this section, a vehicle is recorded in a register kept under a corresponding law to this regulation as a written-off vehicle; and
- (b) after the vehicle was recorded in the register kept under the corresponding law as a written-off vehicle, but before the commencement of this section, the vehicle was registered under this regulation, whether or not it is still registered.

(2) For this regulation, the vehicle is taken not to be recorded as a written-off vehicle in the register kept under the corresponding law.

SCHEDULE 1

CATEGORY 1 VEHICLE REGISTRATION FEES

section 69

PART 1—CATEGORY 1 VEHICLE REGISTRATION FEES FOR 1 YEAR

	\$
1. Motor vehicle with GVM not over 4 t—	
(a) 1, 2 or 3 cylinders, electric or steam	142.40
(b) 4 cylinders or 2 rotors	181.10
(c) 5 or 6 cylinders or 3 rotors.	278.35
(d) 7 or 8 cylinders	389.80
(e) 9–12 cylinders	457.15
2. Motor vehicle, other than a motorised caravan or bus, with GVM over 4 t but not over 4.5 t	436.90
3. Motorised caravan with GVM over 4 t but not over 4.5 t.	317.65
4. Bus with GVM over 4 t but not over 4.5 t	435.45
5. Mobile machinery or equipment with GVM not over 4.5 t—	
(a) with GVM not over 1 t. . . .	99.15
(b) with GVM over 1 t but not over 2 t.	135.90
(c) with GVM over 2 t but not over 3 t.	172.65

*Transport Operations (Road Use
Management—Vehicle Registration) Regulation 1999*

SCHEDULE 1 (continued)

	(d) with GVM over 3 t but not over 4 t	209.45
	(e) with GVM over 4 t but not over 4.5 t	214.65
6.	Tractor with GVM not over 4.5 t	54.85
7.	Motorbike	61.10
8.	Trailer or caravan—	
	(a) ATM not over 1.02 t	55.40
	(b) ATM over 1.02 t but not over 4.5 t	105.55

**PART 2—CATEGORY 1 VEHICLE CONCESSIONAL
REGISTRATION FEES FOR 1 YEAR**

		\$
1.	Ambulance vehicle	49.70
2.	Vehicle, with distance and road use limits imposed by the chief executive, owned by a primary producer and used only in the owner's business as a primary producer—	
	(a) motor vehicle with GCM or GVM not over 4 t	52.35
	(b) motor vehicle with GCM or GVM over 4 t but not over 4.5 t	76.60
	(c) trailer with ATM not over 4.5 t	52.35

*Transport Operations (Road Use
Management—Vehicle Registration) Regulation 1999*

SCHEDULE 1 (continued)

- | | |
|-------------------------------------------------------------------------------------------------------------------------------------------------------------------------------------------------------------------------------------------------------------------------------|------------------------------------------------------------------------------------------------------|
| <p>3. One motor vehicle (other than mobile machinery or equipment) registered in the name of the holder of a Queensland Government Seniors Card</p> | <p style="text-align: right;">the greater of—
(a) 50% of the part 1 fee; and
(b) \$49.70</p> |
| <p>4. Motor vehicle with a GVM or GCM not over 4 t, in circumstances mentioned in the Doc Base Manual.</p> | <p style="text-align: right;">49.70</p> |
| <p>5. Motor vehicle with a GVM or GCM over 4 t but not over 4.5 t, in circumstances mentioned in the Doc Base Manual.</p> | <p style="text-align: right;">the greater of—
(a) 25% of the part 1 fee; and
(b) \$49.70</p> |
| <p>6. One motor vehicle (other than mobile machinery or equipment) registered in the name of the holder of a pensioner concession card issued before 1 July 1994—
(a) with GVM or GCM not over 4 t, in circumstances mentioned in the Doc Base Manual.</p> | <p style="text-align: right;">49.70</p> |
| <p>(b) with GVM over 4 t but not over 4.5 t, in circumstances mentioned in the Doc Base Manual.</p> | <p style="text-align: right;">the greater of—
(a) 25% of the part 1 fee; and
(b) \$49.70</p> |

*Transport Operations (Road Use
Management—Vehicle Registration) Regulation 1999*

SCHEDULE 1 (continued)

- | | |
|------------------------------------------------------------------------------------------------------------------------------------------------------------------------------------------------------------------------------------------------------|------------------------------------------------------------------|
| 7. One motor vehicle (other than mobile machinery or equipment) registered in the name of the holder of a pensioner concession card issued after 30 June 1994 with GVM or GCM not over 4.5 t, in circumstances mentioned in the Doc Base Manual..... | the greater of—
(a) 50% of the part 1 fee; and
(b) \$49.70 |
| 8. Special interest vehicle | 49.70 |

SCHEDULE 2

CATEGORY 2 VEHICLE REGISTRATION FEES

section 69

PART 1—CATEGORY 2 VEHICLE REGISTRATION FEES FOR 1 YEAR

1. Vehicles

Vehicle type	2 axle	3 axle	4 axle	5 axle
Motorised caravans	\$320	\$640	\$960	\$960
Trucks—				
Truck (type 1)	\$320	\$640	\$960	\$960
Truck (type 2)	\$533	\$852	\$2 132	\$2 132
Short combination truck	\$586	\$2 132	\$2 132	\$2 132
Medium combination truck	\$4 051	\$4 051	\$4 371	\$4 371
Long combination truck	\$5 597	\$5 597	\$5 597	\$5 597
Prime movers—				
Short combination prime mover	\$1 386	\$3 624	\$4 690	\$4 690
Medium combination prime mover (B-double)	\$4 264	\$5 330	\$5 863	\$5 863
Long combination prime mover	\$5 330	\$5 330	\$5 863	\$5 863

2. Trailers

Trailers \$320 x number of axles

3. Buses

Bus type	2 axle	3 and 4 axle
Bus (type 1)	\$320	—

SCHEDULE 2 (continued)

Bus (type 2)	\$533	\$1 332
Articulated bus	—	\$533

4. Special purpose vehicles

Special purpose vehicle (type p)—

Tractor \$10.30

Plant, other than drawn plant \$214.00

Special purpose vehicle (type t)—

Mobile machinery \$214.00

Drawn plant \$61.00

Special purpose vehicle (type o) \$266 + (\$266 x number of axles in
excess of 2)

**PART 2—CATEGORY 2 VEHICLE CONCESSIONAL
REGISTRATION FEES FOR 1 YEAR**

1. The percentage of the registration fee for a category 2 vehicle, other than a special interest vehicle or a motorised caravan, payable under a concessional registration is as follows—

- (a) for a truck with 2 or 3 axles—50%;
- (b) for a truck with 4 or more axles—25%;
- (c) for a short or medium combination prime mover, or a short, medium or long combination truck, with 2 axles—50%;
- (d) for a long combination prime mover with 2 axles—25%;
- (e) for a prime mover, or a short, medium or long combination truck, with 3 or more axles—25%;
- (f) for a trailer with 1 axle—50%;
- (g) for a trailer with 2 axles—35%;
- (h) for a trailer with 3 or more axles—30%;

SCHEDULE 2 (continued)

- (i) for a special purpose vehicle—25%;
 - (j) for a caravan, mobile library, mobile workshop, mobile laboratory or mobile billboard—35%;
 - (k) for a bus—50%.
- 2.** The concessional registration fee for a special interest vehicle is \$49.70.
- 3.** The percentage of the registration fee payable under a concessional registration for a motorised caravan owned by a card holder is—
- (a) if the card holder holds a seniors card—50%; or
 - (b) if the card holder holds a pensioner concession card—
 - (i) if the card holder was issued with the pensioner concession card before 1 July 1994—25%; or
 - (ii) otherwise—50%.
- 4.** The concessional registration fee for a vehicle, with distance and road use limits imposed by the chief executive, owned by a primary producer and used only in the owner's business as a primary producer, is—
- (a) if it is a motor vehicle—\$32.05; or
 - (b) if it is a trailer—\$76.60.

SCHEDULE 3

OTHER FEES

section 69

PART 1—PLATE FEES

	\$
1. Limousine number plates.	27.60
2. Fire and rescue appliance plates	31.00
3. Accessory number plate.	18.30
4. Another number plate	18.30
5. Replacement of—	
(a) dealer plate.	67.90
(b) limousine plates.	27.60
(c) another number plate	18.30
6. Replacement plate or pair of plates with the same number and design as the replaced plate or plates	18.30 plus manufacturing costs

PART 2—MISCELLANEOUS FEES

	\$
1. Application for—	
(a) transfer of registration	16.95
(b) transfer of personalised number plates.	61.55

*Transport Operations (Road Use
Management—Vehicle Registration) Regulation 1999*

SCHEDULE 3 (continued)

(c) limited use permit, for each day	16.95
(d) limited use certificate	50.90
(e) replacement registration label	10.00
2. Extract from the register for use in a vehicles safety recall	1.05
	for each vehicle to a maximum of 5 000
3. Extract from the register through a public access provider—	
(a) for each vehicle, if the vehicle's registration number is supplied	10.85
(b) if the name and address of the person in whose name a vehicle is registered are supplied, but not the vehicle's registration number, for each list supplied	6.50
(c) for each vehicle, if information about the vehicle is supplied by electronic or disk file	6.50
(d) for each vehicle, for each extract certified by the chief executive	17.40
4. Extract from the register other than under item 2 or 3—	
(a) for each vehicle, if the vehicle's registration number, VIN, chassis number or engine number is supplied	10.85

*Transport Operations (Road Use
Management—Vehicle Registration) Regulation 1999*

SCHEDULE 3 (continued)

(b) if the name and address of the person in whose name a vehicle is registered are supplied, but not the vehicle's registration number, for each list supplied	6.50
(c) for each vehicle, each extract from archival records	17.40
(d) for each vehicle, for each extract certified by the chief executive	17.40
4A. Obtaining, from a vehicle related information provider, information from the register about a written-off vehicle, if the vehicle related information provider is the chief executive acting through a delegate, for each request	7.40
5. Surcharge for processing an application for registration for less than 1 year—	
(a) category 1 vehicle	6.50
(b) category 2 vehicle	22.80
6. Surcharge for processing an application for renewal of registration for less than 1 year if payable under section 37A—	
(a) category 1 vehicle	6.50
(b) category 2 vehicle	22.80
6A. Surcharge for processing a concession registration in relation to an application for registration for less than 1 year for a category 1 vehicle	3.25

SCHEDULE 3 (continued)

6B. Surcharge for processing a concession registration in relation to an application for renewal of registration for less than 1 year for a category 1 vehicle if payable under section 37A	3.25
7. Customising a number plate ...	30.85
8. Traffic improvement fee for a category 1 vehicle	36.90
9. Registration administration fee for a category 2 vehicle other than a trailer	44.55
10. Registration fee for dealer plate.	296.05
11. Administration fee payable to the chief executive by a vehicle related information provider, for each request for information from the register about a written-off vehicle	4.50
12. Administration fee payable to the chief executive by an entity contracted by the chief executive to operate a written-off vehicle inspection site, for each written-off vehicle inspection	46.20

SCHEDULE 3 (continued)

**PART 3—ADMINISTRATIVE FEES FOR LATE
PAYMENT**

Administration fee payable on payment for renewal of registration after the expiry date—	\$
(a) Renewal of registration of a Category 1 or 2 vehicle (other than a Category 1 trailer, special interest vehicle subject to concession registration, tractor, limited use plate vehicle or drawn plant) or dealer plate	40.00
(b) Otherwise	10.00

SCHEDULE 4

DICTIONARY

section 3

“address” means place of residence or business or, for a corporation, its registered office or place of business.

“administrative fee for late payment” means an administrative fee for late payment under schedule 3.

“agricultural implement” means a vehicle without its own automotive power, built to perform agricultural tasks.

Examples—

Augers, conveyors, empty field bins, harvester fronts, irrigating equipment and machinery fully carried on the three-point linkage of a tractor.

“agricultural machine” means a machine with its own automotive power—

- (a) built to perform agricultural tasks; and
- (b) being used for agricultural purposes.

Examples—

Tractors and harvesters being used for agricultural purposes.

“ambulance vehicle” means a motor vehicle used solely for rendering emergency treatment and pre-hospital patient care to, and the transport of, sick or injured persons by an ambulance service or hospital.

“approved written-off vehicle examiner” means a person approved by the chief executive to perform written-off vehicle inspections.

“approved written-off vehicle nominee” means a person approved by the chief executive to supervise the day to day running of written-off vehicle inspections for an entity

“articulated bus” means a bus with 2 or more rigid sections connected to one another in a way allowing—

- (a) passenger access between the sections; and

SCHEDULE 4 (continued)

(b) rotary movement between the sections.

“ATM” (aggregate trailer mass), for a trailer—

- (a) means the maximum mass, specified by the manufacturer, for the loaded trailer; and
- (b) includes any mass imposed on the vehicle towing the trailer when they are on a horizontal surface.

“auctioneer” means a person who carries on a business that includes selling or attempting to sell or offering for sale or resale notifiable vehicles, or parts of notifiable vehicles having a chassis number or VIN, by auction.

“Australian Design Rule” means a national standard under the *Motor Vehicle Standards Act 1989* (Cwlth), part 2.

“auto parts dismantler” means a person who carries on the business of—

- (a) demolishing or dismantling vehicles or vehicle parts or accessories; or
- (b) buying vehicles and substantially demolished or substantially dismantled vehicles and selling substantially demolished or substantially dismantled vehicles, whether or not the person also sells vehicle parts or accessories.

“axle” means 1 or more shafts positioned in a line across a vehicle, on which 1 or more wheels intended to support the vehicle, turn.

“B-double” means a combination consisting of a prime mover towing 2 semi-trailers, with the first semi trailer being attached directly to the prime mover, and the second semi trailer being mounted on the rear of the first semi trailer.

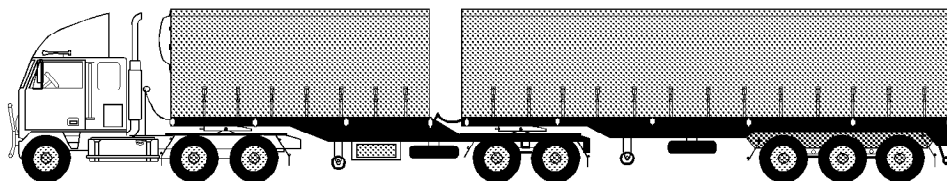

Typical B-double

“bus” means a motor vehicle built mainly to carry 10 or more seated adults, including the driver.

SCHEDULE 4 (continued)

“bus type 1” means a rigid bus with 2 axles and an MRC of not more than 12 t.

“bus type 2” means a rigid bus with—

- (a) 2 axles and an MRC of more than 12 t; or
- (b) 3 or more axles.

“caravan” means an enclosed trailer designed for people to live in.

“card holder” means a person who holds—

- (a) a pensioner concession card; or
- (b) a seniors card.

“category 1 vehicle” means a vehicle with a GVM of not more than 4.5 t.

“category 2 vehicle” means a vehicle with a GVM of more than 4.5 t.

“chassis number”, of a vehicle, means an identification number of the chassis that is permanently marked on the chassis or another part of the vehicle, but does not include the vehicle’s VIN.

“client user”, for part 8, division 5, see section 67.

“CTP insurance premium” means the insurance premium payable under the *Motor Accident Insurance Act 1994* for an insurance certificate under that Act.

“customised number plate” means a number plate customised under section 30.

“damaged” includes significantly deteriorated.

“dealer” means—

- (a) the holder of a motor dealer’s licence under the *Property Agents and Motor Dealers Act 2000* or, other than in section 61, the holder of an equivalent licence or other authority under a corresponding law; or
- (b) a person whose business is the sale of new motor vehicles or new or used trailers.

“dealer plate” means a number plate included in a series of number plates designated by the chief executive as dealer plates.

SCHEDULE 4 (continued)

“Doc Base Manual” means the manual of policies and procedures issued by the chief executive for administering the scheme of vehicle registration established under this regulation.

“drawn plant” means a machine built on a trailer base, other than an agricultural implement.

“eligible person”, for part 8, division 5, see section 67.

“equipment trailer” means a trailer that is a special purpose vehicle built to transport machinery forming an integral part of the trailer.

“exempt vehicle” see section 4.

“fire and rescue appliance” means a vehicle—

- (a) built or modified for—
 - (i) fighting fires; or
 - (ii) supporting or performing rescue operations; and
- (b) approved by the chief executive under the *Fire and Rescue Service Act 1990* as a suitably built or modified vehicle; and
- (c) operated by authorised fire officers under the *Fire and Rescue Service Act 1990*.

“garage address” of a vehicle, means the principal depot or base of operations of the vehicle.

“GCM” (gross combination mass), of a motor vehicle, means the maximum loaded mass for the motor vehicle and any vehicles it may lawfully tow—

- (a) stated by the vehicle’s manufacturer—
 - (i) on the vehicle’s compliance plate; or
 - (ii) if there is no compliance plate—in another place; or
- (b) stated by the chief executive or the corresponding authority under a corresponding law to the Act, if—
 - (i) the vehicle’s manufacturer has not stated the vehicle’s maximum loaded mass; or
 - (ii) the manufacturer cannot be identified; or

SCHEDULE 4 (continued)

- (iii) the vehicle has been modified and the maximum loaded mass stated by the manufacturer is no longer appropriate; or
 - (c) stated in an evaluation report about the vehicle given by an accredited person.
- “GTMR”** (gross trailer mass rating), of a trailer, means the mass transmitted to the ground by the axles of the trailer when—
- (a) coupled to a towing vehicle; and
 - (b) carrying its maximum load approximately uniformly distributed over the trailer’s load bearing area.
- “historic ambulance vehicle”** means a vehicle that was used as an ambulance vehicle but is now used for display by an ambulance service or historical ambulance society.
- “historic fire-fighting equipment”** means a vehicle that was used for fire-fighting but is now used for display by an historical fire brigade society.
- “identifying number”** means—
- (a) a chassis number; or
 - (b) an engine number; or
 - (c) a VIN.
- “insolvency entity”**, for part 8, division 5, see section 67.
- “insurer”** means a body corporate authorised under the *Insurance Act 1973* (Cwlth) to carry on insurance business.
- “involved person”**, for part 8, division 5, see section 67.
- “late-model vehicle”** means a vehicle that is not more than 15 years old, counting from its date of manufacture.
- “litigation”**, for part 8, division 5, see section 67.
- “load”**, of a vehicle, includes—
- (a) anything normally taken from the vehicle when it is not in use; and
 - (b) anything that may fall from the vehicle when it is in motion.

SCHEDULE 4 (continued)

“loaded mass”, of a vehicle, means the vehicle’s mass together with the mass of the vehicle’s load transmitted to the ground.

“local agency”, for part 8, division 5, see section 67.

“long combination prime mover” means a prime mover, other than a medium combination prime mover, nominated to haul 2 or more trailers.

“long combination truck” means a truck nominated to tow 2 or more trailers.

“loss adjuster” means a person who assesses the extent of loss or damage involving a vehicle for or on behalf of another person.

“lowest premium set by any CTP insurer” means the lowest CTP insurance premium set by any licensed insurer under the *Motor Accident Insurance Act 1994*, section 13A²¹ for the class of CTP insurance that relates to the vehicle for which an application for renewal of registration has been made.

“low loader” means a gooseneck semi trailer with a loading deck 1 m or less above the ground.

“low loader dolly” means a mass distributing device that—

- (a) is of the type usually coupled between a prime mover and a low loader; and
- (b) consists of a gooseneck rigid frame; and
- (c) does not carry any load directly on itself; and
- (d) is equipped with 1 or more axles, a kingpin and a fifth wheel coupling.

“low powered motor vehicle” means a motor vehicle propelled by—

- (a) a motor with a maximum power output of not more than 200 watts; or
- (b) 2 or more motors with a combined maximum power output of not more than 200 watts.

²¹ *Motor Accident Insurance Act 1994*, section 13A (Premium rates)

SCHEDULE 4 (continued)

“medium combination prime mover” means a prime mover nominated to be the prime mover for a B-double.

“medium combination truck” means a truck, other than a short combination truck, nominated to haul 1 trailer.

“minimum available registration term”, for a vehicle, means—

- (a) if the vehicle is a category 2 vehicle—3 months; or
- (b) otherwise—6 months.

“mobile machinery” means a motor vehicle that—

- (a) is built to transport and operate machinery or equipment forming an integral part of the vehicle; and
- (b) is not—
 - (i) a truck, semi-trailer or prime mover; or
 - (ii) a tow truck; or
 - (iii) a tractor.

“motorised caravan” means a motor vehicle designed mainly for people to live in.

“motorised golf buggy” means a motor vehicle that—

- (a) is designed as transport for persons playing, or persons associated with persons playing, golf; and
- (b) can not be driven faster than 10 km/h.

“motorised invalid chair” means a motor vehicle that—

- (a) is designed and constructed for use by a seated person with mobility difficulties; and
- (b) is not capable of going faster than 10 km/h; and
- (c) has a tare of not more than 110 kgs.

“motor race” means a race involving motor vehicles, or a practice or a time trial for a race or competition involving 1 or more motor vehicles.

“MRC” (mass rating for charging), of a vehicle, means the maximum permissible mass of the vehicle and its load—

SCHEDULE 4 (continued)

- (a) shown on the vehicle's compliance plate as the GVM, GTMR or ATM of the vehicle; or
- (b) for a vehicle without a compliance plate—decided by the chief executive or the corresponding authority under a corresponding law to the Act, having regard to the design and construction of—
 - (i) the vehicle; or
 - (ii) any of its components.

“nominated”, in relation to a vehicle, means nominated in an application for registration of the vehicle.

“nominated configuration”, for a category 2 vehicle, means the configuration in which the vehicle is nominated to operate for the term of its registration.

“notifiable information”, for a written-off vehicle, means—

- (a) the vehicle's chassis number or VIN; and
- (b) the vehicle's engine number, if available; and
- (c) if the vehicle has been assessed as a total loss—when the vehicle was assessed to be a total loss; and
- (d) whether the vehicle is a repairable write-off or a statutory write-off; and
- (e) the type, location and severity of the damage to the vehicle; and
- (f) details of the person providing the information mentioned in paragraphs (a) to (e).

“notifiable vehicle” means—

- (a) a vehicle that—
 - (i) is a late-model vehicle of 1 of the following types—
 - (A) a motor vehicle with a GVM not over 4.5 t;
 - (B) a motorbike;
 - (C) a caravan;
 - (D) a trailer with an ATM over 4.5 t; and

SCHEDULE 4 (continued)

- (ii) complies with the requirements of all Australian Design Rules applying to it; or
- (b) any other vehicle of a type notified by the chief executive by gazette notice.

“notifier” means any of the following—

- (a) an insurer;
- (b) a self-insurer;
- (c) a loss adjuster;
- (d) a dealer;
- (e) an auctioneer;
- (f) an auto parts dismantler.

“passengers”, of a vehicle, does not include the driver or a trainee driver of the vehicle or a person in the vehicle who is necessary for the normal operation of the vehicle.

“pensioner concession card” means a card known as a pensioner concession card issued under a Commonwealth law.

“personal information”, for part 8, division 5, see section 67.

“personalised number plate” means a number plate issued under section 27 as a personalised number plate.

“plant” means a machine with its own automotive power.

“pole-type trailer” means a trailer that—

- (a) is attached to a towing vehicle by a pole, or an attachment fitted to the pole; and
- (b) is ordinarily used for transporting loads, such as logs, pipes, structural members, or other long objects, that are generally capable of supporting themselves like beams between supports.

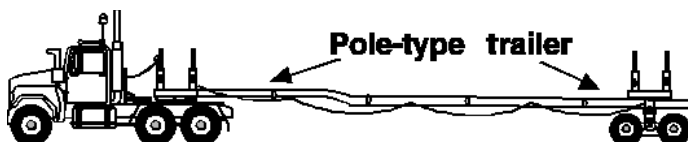

SCHEDULE 4 (continued)

“primary produce” means—

- (a) tobacco; or
- (b) raw material for clothing or food derived from—
 - (i) agriculture; or
 - (ii) dairying; or
 - (iii) fishing; or
 - (iv) the raising of livestock; or
 - (v) viticulture.

“primary producer” means a person engaged mainly in the production of primary produce.

“primary production vehicle” means a vehicle that is—

- (a) owned by a person who is a primary producer; and
- (b) used only for carrying on the person’s business as a primary producer; and
- (c) either of the following—
 - (i) a prime mover or truck with a GVM of 6 t or over 6 t;
 - (ii) a trailer with an MRC of over 4.5 t.

“prime mover” means a motor vehicle designed to tow a semi trailer.

“public access provider”, for part 8, division 5, see section 67.

“racing track” means a circuit or track, not dedicated to public use as a road, being used as a course for a motor race or motor race driver training, if other traffic is excluded from the circuit or track during its use for the race or training.

“racing vehicle” means a vehicle that is used in a motor race or for motor race driver training.

“recklessly” includes with gross negligence.

“register”, as a noun, see section 15.

“registered operator”, of a vehicle or dealer plate, see section 4A.

SCHEDULE 4 (continued)

“registration certificate”, for a vehicle, means a certificate issued by the chief executive and including the matters about the vehicle listed in section 16(2).

“registration label”, for a vehicle, means a label issued by the chief executive and including the matters about the vehicle listed in section 32(2).

“registration number” means a distinguishing number—

- (a) assigned by the chief executive to identify a vehicle that is, or has been, registered; and
- (b) displayed, or intended for display, on a number plate.

“registration-related amount”, for a renewal of registration, means the total of—

- (a) the relevant registration fee payable under section 37(1)(a); and
- (b) any category 1 vehicle traffic improvement fee payable under section 37(1)(b); and
- (c) any CTP insurance premium payable under section 37(1)(c); and
- (d) any administrative fee for late payment payable for the renewal.

“related area”, for a racing track, means an area—

- (a) adjacent to the racing track where a racing vehicle is parked or driven for a purpose associated with the motor race or motor race driver training; and
- (b) not dedicated to public use as a road.

“renewal notice” see section 36.

“repairable write-off”—

- (a) means a notifiable vehicle that is a total loss but is not a statutory write-off; and
- (b) in the context of a written-off vehicle inspection and a written-off vehicle inspection report, includes a vehicle with a chassis number or VIN that is the same as the chassis number or VIN of a vehicle recorded in the register, or in a register kept under a corresponding law to this regulation, as a repairable write-off.

“road related area” means an area that is part of a road and—

SCHEDULE 4 (continued)

- (a) divides a part of the road from another part of the road and is formed by lines marked on the road or is constructed on the road; or
- (b) is a footpath or nature strip; or
- (c) is open to the public and is designed for use by cyclists or animals.

Example for paragraph (a)—

Traffic island.

“Road Use Management Regulation” means the *Transport Operations (Road Use Management) Regulation 1995*.

“safety recall agency” for part 8, division 5, see section 67.

“sale”, of a vehicle, includes—

- (a) the hiring of the vehicle on hire purchase; and
- (b) the leasing of the vehicle.

“self-insurer” means an entity that owns 5 or more notifiable vehicles for which there is no insurance policy with an insurer covering loss or damage.

“semi trailer” means a trailer (including a pole type trailer) that—

- (a) has 1 axle group towards the rear; and
- (b) is attached to its towing vehicle—
 - (i) using a turntable or a fifth wheel coupling; and
 - (ii) in a way that results in some of the load being imposed on the towing vehicle.

“seniors card” means a Queensland Government seniors card.

“short combination prime mover” means a prime mover nominated to tow 1 semi trailer.

“short combination truck” means a truck nominated to haul 1 trailer, if the combination has—

- (a) 6 or fewer axles; and
- (b) a total mass of not more than 42.5 t.

SCHEDULE 4 (continued)

“special interest vehicle” means—

- (a) a vehicle that is at least 30 years old; or
- (b) an historic ambulance vehicle or historic firefighting equipment;
or
- (c) a street rod vehicle.

“special plate” means—

- (a) a customised number plate; or
- (b) a personalised number plate.

“special purpose vehicle” means—

- (a) a forklift, straddle carrier, mobile cherry picker or mobile crane;
or
- (b) a vehicle, other than a vehicle mentioned in paragraph (a) or a caravan, motorised caravan, mobile library, mobile workshop, mobile laboratory or mobile billboard, that has been built, or permanently modified, for a purpose other than for carrying goods or passengers.

“special purpose vehicle (type o)” means a special purpose vehicle, other than a special purpose vehicle (type p), that—

- (a) is built, or permanently modified, primarily for use on roads; and
- (b) has at least 1 axle or axle group loaded above the axle load limits stated in the *Transport Operations (Road Use Management) Regulation 1995*, section 10 and schedule 3.²²

“special purpose vehicle (type p)” means a special purpose vehicle built or permanently modified for—

- (a) off-road use; or
- (b) use on a road related area; or
- (c) use on an area of road that is under construction.

²² *Transport Operations (Road Use Management) Regulation 1995*, section 10 (Axles) and schedule 3 (Axle load limits)

SCHEDULE 4 (continued)

“special purpose vehicle (type t)” means a special purpose vehicle, other than a special purpose vehicle (type p), that—

- (a) is built, or permanently modified, primarily for use on roads; and
- (b) has no axle or axle group loaded above the axle load limits stated in the *Transport Operations (Road Use Management) Regulation 1995*, section 10 and schedule 3.

Examples of special purpose type vehicles (type t)—

Mobile cranes, fire engines, truck mounted concrete pumps and boring plants.

“statutory entity” for part 8, division 5, see section 67.

“statutory write-off” means a notifiable vehicle that is a total loss and that is—

- (a) a motor vehicle or trailer, other than a motor bike, that has been immersed—
 - (i) in salt water above the doorsill level for any period; or
 - (ii) in fresh water up to the dashboard or steering wheel for more than 48 hours; or
- (b) a motor bike that has been fully immersed—
 - (i) in salt water for any period; or
 - (ii) in fresh water for more than 48 hours; or
- (c) a motor vehicle or trailer that has been burnt to the extent that it is fit only for wrecking or scrap; or
- (d) a motor vehicle or trailer that has been stripped of all, or a combination or most, interior and exterior body parts, panels and components; or

Examples of body parts, panels and components—

Engine, wheels, bonnet, guards, doors, boot lid.

- (e) a motor vehicle, other than a motor bike, that has been damaged to the extent of at least 3 of the following impact damage indicators—
 - (i) damage to an area of the roof equal to or exceeding 300 mm by 300 mm;

SCHEDULE 4 (continued)

- (ii) damage to an area of the cabin floor pan equal to or exceeding 300 mm by 300 mm;
- (iii) damage to an area of the firewall equal to or exceeding 300 mm by 300 mm;
- (iv) damage to the suspension;
- (v) damage in the form of cracks or breaks to major mechanical components; or

Examples of major mechanical components—

Engineblock, transmission casings.

- (f) a motor bike that has—
 - (i) impact damage, other than scratching, to the suspension; and
 - (ii) at least 2 areas of structural frame damage.

“street rod vehicle” means a motor vehicle modified for safe road use that—

- (a) has a body and frame built before 1949; or
- (b) is a replica of a motor vehicle the body and frame of which were built before 1949.

“tare”, of a vehicle, means the total of the following—

- (a) the mass of the vehicle when unloaded;
- (b) the mass of the fuel, water, lubricants and tools, and of any equipment and accessories, loaded on the vehicle and necessary for its normal operation.

“total loss” means a notifiable vehicle damaged by accident, collision, demolition, dismantling, fire, flood, trespass or other event to the extent that its fair salvage value, when added to the cost of repairing it for use on a road or road related area, would be more than its fair market value immediately before the event that caused the damage.

“tow truck” means a motor vehicle equipped with a lifting or loading device capable of being used for the towing of a motor vehicle.

“tractor” means a motor vehicle used for towing purposes, other than a motor vehicle—

SCHEDULE 4 (continued)

- (a) designed to carry passengers or goods (other than its own fuel or water); or
- (b) that is a tow truck.

“truck” means a rigid motor vehicle built mainly as a load carrying vehicle.

“truck (type 1)” means a truck with—

- (a) 2 axles and an MRC of not more than 12 t; or
- (b) 3 axles and an MRC of not more than 16.5 t; or
- (c) 4 or more axles and an MRC of not more than 20 t.

“truck (type 2)” means a truck with—

- (a) 2 axles and an MRC of more than 12 t; or
- (b) 3 axles and an MRC of more than 16.5 t; or
- (c) 4 or more axles and an MRC of more than 20 t.

“use”, of a vehicle on a road, includes standing the vehicle on the road.

“vehicle law” means—

- (a) the Road Use Management Regulation; or
- (b) the Vehicle Standards and Safety Regulation, to the extent the regulation requires compliance with the vehicle standards mentioned in the regulation.

“vehicle related information”, for part 8, division 5, see section 67.

“vehicle related information provider”, for part 8, division 5, see section 67.

“Vehicle Standards and Safety Regulation” means the *Transport Operations (Road Use Management—Vehicle Standards and Safety) Regulation 1999*.

“VIN”, of a vehicle, means the unique vehicle identification number assigned to the vehicle.

“walking speed equipment” means a motor vehicle—

- (a) used for construction, maintenance or warehouse operation; and
- (b) designed mainly for use outside the road system; and

SCHEDULE 4 (continued)

(c) not capable of going faster than 10 km/h.

“written-off vehicle” means a vehicle that is—

- (a) a repairable write-off; or
- (b) a statutory write-off.

“written-off vehicle inspection” means an inspection of a repairable write-off, in accordance with procedures approved by the chief executive, to decide on the vehicle’s identity.

“written-off vehicle inspection report” means a report of a written-off vehicle inspection that includes a decision of an approved written-off vehicle examiner that the vehicle’s identity is legitimate.

“written-off vehicle inspection site” means a place where written-off vehicle inspections are performed.

ENDNOTES

1 Index to endnotes

		Page
2	Date to which amendments incorporated	119
3	Key	119
4	Table of reprints	120
5	List of legislation	120
6	List of annotations	122

2 Date to which amendments incorporated

This is the reprint date mentioned in the Reprints Act 1992, section 5(c). Accordingly, this reprint includes all amendments that commenced operation on or before 1 February 2003. Future amendments of the Transport Operations (Road Use Management—Vehicle Registration) Regulation 1999 may be made in accordance with this reprint under the Reprints Act 1992, section 49.

3 Key

Key to abbreviations in list of legislation and annotations

Key	Explanation	Key	Explanation
AIA	= Acts Interpretation Act 1954	(prev)	= previously
amd	= amended	proc	= proclamation
amdt	= amendment	prov	= provision
ch	= chapter	pt	= part
def	= definition	pubd	= published
div	= division	R[X]	= Reprint No.[X]
exp	= expires/expired	RA	= Reprints Act 1992
gaz	= gazette	reloc	= relocated
hdg	= heading	renum	= renumbered
ins	= inserted	rep	= repealed
lap	= lapsed	(retro)	= retrospectively
notfd	= notified	rv	= revised edition
o in c	= order in council	s	= section
om	= omitted	sch	= schedule
orig	= original	sdiv	= subdivision
p	= page	SIA	= Statutory Instruments Act 1992
para	= paragraph	SIR	= Statutory Instruments Regulation 2002
prec	= preceding	SL	= subordinate legislation
pres	= present	sub	= substituted
prev	= previous	unnum	= unnumbered

*Transport Operations (Road Use
Management—Vehicle Registration) Regulation 1999*

4 Table of reprints

Reprints are issued for both future and past effective dates. For the most up-to-date table of reprints, see the latest reprint.

If a reprint number includes a letter of the alphabet, the reprint was released in unauthorised, electronic form only.

TABLE OF REPRINTS

Reprint No.	Amendments included	Effective	Reprint date
1	none	1 October 1999	1 October 1999
1A	to SL No. 286 of 1999	1 December 1999	17 January 2000
1B	to SL No. 90 of 2000	1 July 2000	18 August 2000
1C	to SL No. 297 of 2000	27 November 2000	6 December 2000
1D	to SL No. 28 of 2001	6 April 2001	20 April 2001
1E	to SL No. 145 of 2001	1 October 2001	5 October 2001
2	to SL No. 145 of 2001	1 October 2001	2 November 2001
2A	to SL No. 248 of 2001	7 December 2001	14 December 2001
2B	to SL No. 248 of 2001	1 February 2002	1 February 2002
			(Column discontinued) Notes
2C	to SL No. 112 of 2002	1 July 2002	
2D	to SL No. 199 of 2002	19 August 2002	
2E	to SL No. 199 of 2000	1 September 2002	
2F	to SL No. 251 of 2002	30 September 2002	
2G	to SL No. 366 of 2002	1 February 2003	

5 List of legislation

Transport Operations (Road Use Management—Vehicle Registration) Regulation 1999 SL No. 225

made by the Governor in Council on 30 September 1999

notfd gaz 1 October 1999 pp 468–9

ss 1–2 commenced on date of notification

pt 8 div 5, sch 3 pt 2 items 2–4 commenced 1 January 2000 (see s 2(2))

remaining provisions commenced 1 October 1999 (see s 2(1))

exp 1 September 2010 (see SIA s 54)

amending legislation—

Road Transport Reform Regulation 1999 SL No. 286 ss 1, 2(2), 4 sch 2

notfd gaz 19 November 1999 pp 1149–52

ss 1–2 commenced on date of notification

remaining provisions commenced 1 December 1999 (see s 2(2))

**Transport Operations (Road Use Management—Vehicle Registration) Amendment
Regulation (No. 1) 2000 SL No. 90**

notfd gaz 19 May 2000 pp 218–19
ss 1–2 commenced on date of notification
remaining provisions commenced 1 July 2000 (see s 2)

**Transport Legislation Amendment Regulation (No. 4) 2000 SL No. 297 pts 1, 8 s 44
sch 2**

notfd gaz 24 November 2000 pp 1188–9
ss 1–2 commenced on date of notification
remaining provisions commenced 27 November 2000 (see s 2)

Transport Legislation Amendment Regulation (No. 1) 2001 SL No. 28 pts 1, 5

notfd gaz 6 April 2001 pp 1452–3
commenced on date of notification

Transport Legislation Amendment Regulation (No. 2) 2001 SL No. 57 pts 1, 11

notfd gaz 25 May 2001 pp 334–6
ss 1–2 commenced on date of notification
remaining provisions commenced 1 July 2001 (see s 2)

**Transport Operations (Road Use Management—Vehicle Registration) Amendment
Regulation (No. 1) 2001 SL No. 145**

notfd gaz 24 August 2001 pp 1526–9
ss 1–2 commenced on date of notification
remaining provisions commenced 1 October 2001 (see s 2)

**Transport Operations (Road Use Management—Vehicle Registration) Amendment
Regulation (No. 3) 2001 SL No. 248**

notfd gaz 7 December 2001 pp 1270–1
ss 10, 11, 15(3) commenced 1 February 2002 (see s 2)
remaining provisions commenced on date of notification

Transport Legislation Amendment Regulation (No. 2) 2002 SL No. 112 pts 1, 14

notfd gaz 24 May 2002 pp 308–10
ss 1–2 commenced on date of notification
remaining provisions commenced 1 July 2002 (see s 2)

**Transport Operations (Road Use Management—Vehicle Registration) Amendment
Regulation (No. 1) 2002 SL No. 185**

notfd gaz 26 July 2002 pp 1212–13
ss 1–2 commenced on date of notification
remaining provisions commenced 1 September 2002 (see s 2)

Transport Legislation Amendment Regulation (No. 3) 2002 SL No. 199 pts 1, 4

notfd gaz 16 August 2002 pp 1420–21
ss 1–2 commenced on date of notification
remaining provisions commenced 19 August 2002 (see s 2)

Transport Legislation Amendment Regulation (No. 4) 2002 SL No. 251 pts 1, 3, s 22 sch

notfd gaz 27 September 2002 pp 340–4
ss 1–2 commenced on date of notification
remaining provisions commenced 30 September 2002 (see s 2)

Transport Operations (Road Use Management—Vehicle Registration) Amendment Regulation (No. 2) 2002 SL No. 366

notfd gaz 20 December 2002 pp 1359–63
ss 1–2 commenced on date of notification
remaining provisions commenced 1 February 2003 (see s 2)

6 List of annotations

Meaning of “exempt vehicle”

s 4 amd 2000 SL No. 297 s 45; 2001 SL No. 248 s 4

Meaning of “registered operator” in this regulation

s 4A ins 2000 SL No. 297 s 46

PART 3—VEHICLE REGISTRATION

Vehicles used on roads must be registered

s 10 amd 2001 SL No. 28 s 23

Application for registration

s 11 amd 2000 SL No. 297 s 47; 2001 SL No. 28 s 24; 2002 SL No. 251 s 22 sch

Driving or towing unregistered vehicle to place for inspection

prov hdg amd 2002 SL No. 251 s 6(1)

s 12A ins 2001 SL No. 28 s 25
amd 2002 SL No. 251 s 6(2)–(3)

Vehicle inspections

s 13 amd 1999 SL No. 286 s 4 sch 2; 2000 SL No. 297 s 44 sch 2
sub 2002 SL No. 251 s 7

Determination of applications

s 14 amd 2001 SL No. 28 s 26; 2002 SL No. 251 s 8

Registered vehicles register

s 15 amd 2000 SL No. 297 s 44 sch 2; 2002 SL No. 251 s 9; 2002 SL No. 366 s 4

Registration certificates

s 16 amd 2000 SL No. 297 s 44 sch 2

Registered operator to notify change of particulars

prov hdg amd 2000 SL No. 297 s 44 sch 2

s 17 amd 2000 SL No. 297 s 44 sch 2

Recording change in vehicle particulars and reassessment of registration fee

s 18 amd 2000 SL No. 297 s 44 sch 2; 2002 SL No. 251 s 10

*Transport Operations (Road Use
Management—Vehicle Registration) Regulation 1999*

Seasonal registration

s 20 amd 2000 SL No. 297 s 44 sch 2; 2001 SL No. 248 s 5

Limited use registration

s 22 amd 2000 SL No. 90 s 4

Chief executive to assign registration number and issue number plates

s 23 amd 2000 SL No. 297 s 44 sch 2

Position, visibility and legibility of number plate

prov hdg sub 2000 SL No. 297 s 48(1)

s 24 amd 1999 SL No. 286 s 4 sch 2; 2000 SL No. 297 ss 48(2)–(4), 44 sch 2

Time for attaching number plates

s 25 amd 2000 SL No. 297 s 44 sch 2

Customised number plates

s 30 amd 2000 SL No. 297 s 44 sch 2

Accessory plate for tow truck

s 31A ins 2000 SL No. 297 s 49

Chief executive to issue registration labels

s 32 amd 2000 SL No. 297 s 44 sch 2

Position for attaching registration label

s 33 amd 2000 SL No. 297 s 44 sch 2

Time for attaching registration label

s 34 amd 2000 SL No. 297 s 44 sch 2

Division 6—Further obligations of registered operator

div hdg sub 2000 SL No. 297 s 44 sch 2

om 2002 SL No. 251 s 11

Vehicle destroyed or written off

s 35 amd 2000 SL No. 297 s 44 sch 2

om 2002 SL No. 251 s 11

Registration renewal notice

s 36 amd 2000 SL No. 297 s 44 sch 2

Renewal of registration

s 37 amd 2000 SL No. 297 s 44 sch 2; 2002 SL No. 366 s 5

When surcharge is payable for renewal

s 37A ins 2002 SL No. 366 s 6

**Registration term if overpayment or underpayment of registration-related amount
and any surcharge**

s 37B ins 2002 SL No. 366 s 6

Issue of receipt and updating of records

s 38 amd 2000 SL No. 297 s 44 sch 2

Transfer of registration

s 39 amd 2000 SL No. 297 s 44 sch 2; 2002 SL No. 251 s 22 sch

*Transport Operations (Road Use
Management—Vehicle Registration) Regulation 1999*

Transfer of registration under legal process

s 41 amd 2000 SL No. 297 ss 50, 44 sch 2

Refusing to register transfer of registration

s 42 amd 2002 SL No. 251 s 22 sch

Return of registration plates when registration expires

s 44 amd 2000 SL No. 297 s 44 sch 2

Cancellation of registration at registered operator's request

prov hdg amd 2000 SL No. 297 s 44 sch 2

s 45 amd 2000 SL No. 297 s 44 sch 2; 2002 SL No. 251 s 12

Cancellation if registration in other State

s 45A ins 2001 SL No. 248 s 6

Partial refund of registration fee

s 46 amd 2000 SL No. 297 s 44 sch 2; 2001 SL No. 248 s 7

Cancellation for noncompliance with defect notice

s 47 amd 2000 SL No. 297 s 44 sch 2

Cancellation of registration of vehicle or dealer plate

s 48 amd 2000 SL No. 297 s 44 sch 2; 2001 SL No. 248 s 8; 2002 SL No. 251 s 13

Recording cancellation of registration in register

s 49 amd 2000 SL No. 297 ss 51, 44 sch 2; 2001 SL No. 248 s 9; 2002 SL No. 251
s 14

Unregistered vehicle permits

s 50 amd 2000 SL No. 297 s 44 sch 2

Attaching dealer plate

s 53 amd 2000 SL No. 297 s 52

PART 7A—WRITTEN-OFF VEHICLES

pt 7A (ss 55A–55ZB) ins 2002 SL No. 251 s 15

Replacement registration items

s 56 amd 2000 SL No. 297 s 44 sch 2

Chief executive may require exchange of number plates

s 57 amd 2000 SL No. 297 s 44 sch 2

Chief executive may require return of number plates

s 58 amd 2000 SL No. 297 s 53

Permit to use intercepted unregistered vehicle on road

s 63 amd 1999 SL No. 286 s 4 sch 2

Damaged or dirty number plates

s 64 amd 2000 SL No. 297 s 44 sch 2

Decision to which this division applies

s 65 amd 2002 SL No. 251 s 16

*Transport Operations (Road Use
Management—Vehicle Registration) Regulation 1999*

Review of decisions

s 66 amd 2002 SL No. 251 s 22 sch

Definitions for div 5

s 67 sub 2000 SL No. 297 s 54

def “**personal information**” ins 2001 SL No. 248 s 10

def “**vehicle related information**” ins 2001 SL No. 248 s 10

sub 2002 SL No. 251 s 17(1)–(2)

def “**vehicle related information provider**” ins 2001 SL No. 248 s 10

def “**written-off vehicle information**” ins 2002 SL No. 251 s 17(2)

Release of information on payment of fee

s 68 sub 2000 SL No. 297 s 54

Release of vehicle related information on payment of a fee

s 68A ins 2001 SL No. 248 s 11

amd 2002 SL No. 251 s 18

Charging categories

s 70 amd 2000 SL No. 297 s 55

Exemption from payment of fee

s 71 amd 2000 SL No. 297 s 44 sch 2

Concessional registration fees—category 1 vehicles

s 72 amd 2000 SL No. 297 s 44 sch 2

Offences involving registration certificates etc

s 76 amd 2000 SL No. 297 s 56

PART 11—TRANSITIONAL PROVISIONS

pt hdg sub 2002 SL No. 251 s 19(1)

Division 1—Transitional provisions for Transport Operations (Road Use Management—Vehicle Registration) Regulation 1999

div hdg ins 2002 SL No. 251 s 19(2)

Division 2—Transitional provision for written-off vehicle amendments

div hdg ins 2002 SL No. 251 s 19(3)

Registration of vehicle recorded as a written-off vehicle under corresponding law

s 84 prev s 84 om R1 (see RA s 40)

pres s 84 ins 2002 SL No. 251 s 19(3)

PART 12—AMENDMENT OF JUSTICES REGULATION 1993

pt hdg om R1 (see RA s 40)

Omission of sch 1, pt 43

s 85 om R1 (see RA s 40)

Amendment of sch 1, pt 45B

s 86 om R1 (see RA s 40)

Insertion of new sch 1, pt 45E

s 87 om R1 (see RA s 40)

PART 13—AMENDMENT OF TRAFFIC REGULATION 1962

pt 13 (ss 88–89) om R1 (see RA s 40)

PART 14—AMENDMENT OF TRANSPORT OPERATIONS (ROAD USE MANAGEMENT) REGULATION 1995

pt 14 (ss 90–99) om R1 (see RA s 40)

SCHEDULE 1—CATEGORY 1 VEHICLE REGISTRATION FEES

- sub 2000 SL No. 90 s 5
- amd 2000 SL No. 297 ss 57, 44 sch 2
- sub 2001 SL No. 57 s 22
- amd 2001 SL No. 248 s 12
- sub 2002 SL No. 112 s 28; 2002 SL No. 185 s 4

SCHEDULE 2—CATEGORY 2 VEHICLE REGISTRATION FEES

- sub 2000 SL No. 90 s 5
- amd 2000 SL No. 297 s 58
- sub 2001 SL No. 57 s 22
- amd 2001 SL No. 145 s 4; 2001 SL No. 248 s 13
- sub 2002 SL No. 112 s 28
- amd 2002 SL No. 185 s 4

SCHEDULE 3—OTHER FEES

- sub 2000 SL No. 90 s 5; 2001 SL No. 57 s 22; 2001 SL No. 248 s 14; 2002 SL No. 112 s 28
- amd 2002 SL No. 199 s 9; 2002 SL No. 251 s 20; 2002 SL No. 366 s 7

SCHEDULE 4—DICTIONARY

- def “**administrative fee for late payment**” ins 2002 SL No. 366 s 8
- def “**agricultural machine**” sub 2000 SL No. 297 s 59(1)–(2)
- def “**approved written-off vehicle examiner**” ins 2002 SL No. 251 s 21
- def “**approved written-off vehicle nominee**” ins 2002 SL No. 251 s 21
- def “**auctioneer**” ins 2002 SL No. 251 s 21
- def “**Australian Design Rule**” ins 2002 SL No. 251 s 21
- def “**auto parts dismantler**” ins 2002 SL No. 251 s 21
- def “**axle**” sub 2000 SL No. 90 s 6(1)–(2)
- def “**bus**” amd 2000 SL No. 297 s 59(3)
- def “**bus type 2**” amd 2000 SL No. 90 s 6(3)
- def “**chassis number**” ins 2002 SL No. 251 s 21
- def “**CTP insurance premium**” ins 2002 SL No. 366 s 8
- def “**dealer**” amd 2000 SL No. 297 s 59(4); 2002 SL No. 251 s 22 sch
- def “**drawn plant**” ins 2000 SL No. 90 s 6(2)
- def “**fire and rescue appliance**” ins 2000 SL No. 297 s 59(2)
- amd 2001 SL No. 248 s 15(4); 2002 SL No. 251 s 22 sch
- def “**identifying number**” ins 2002 SL No. 251 s 21
- def “**insolvency entity**” ins 2001 SL No. 248 s 15(2)
- def “**insurer**” ins 2002 SL No. 251 s 21
- def “**late-model vehicle**” ins 2002 SL No. 251 s 21
- def “**long combination prime mover**” ins 2000 SL No. 90 s 6(2)
- def “**long combination prime mover (type 1)**” om 2000 SL No. 90 s 6(1)
- def “**long combination prime mover (type 2)**” om 2000 SL No. 90 s 6(1)

*Transport Operations (Road Use
Management—Vehicle Registration) Regulation 1999*

- def “**loss adjuster**” ins 2002 SL No. 251 s 21
- def “**lowest premium set by any CTP insurer**” ins 2002 SL No. 366 s 8
- def “**low loader**” ins 2000 SL No. 297 s 59(2)
- def “**low loader dolly**” ins 2000 SL No. 297 s 59(2)
- def “**medium combination truck**” sub 2000 SL No. 90 s 6(1)–(2)
- def “**minimum available registration term**” ins 2002 SL No. 366 s 8
- def “**motorcycle**” om 2000 SL No. 297 s 59(1)
- def “**motor race**” ins 2001 SL No. 248 s 15(2)
- def “**notifiable information**” ins 2002 SL No. 251 s 21
- def “**notifiable vehicle**” ins 2002 SL No. 251 s 21
- def “**notifier**” ins 2002 SL No. 251 s 21
- def “**passengers**” ins 2000 SL No. 90 s 6(2)
- def “**passenger vehicle**” om 2000 SL No. 297 s 59(1)
- def “**personal information**” ins 2001 SL No. 248 s 15(3)
- def “**plant**” ins 2000 SL No. 90 s 6(2)
- def “**pole type trailer**” amd 2000 SL No. 90 s 6(4)
- def “**primary produce**” amd 2000 SL No. 297 s 59(5)
- def “**primary production vehicle**” sub 2001 SL No. 248 s 15(1)–(2)
- def “**racing track**” ins 2001 SL No. 248 s 15(2)
- def “**racing vehicle**” ins 2001 SL No. 248 s 15(2)
- def “**recklessly**” ins 2002 SL No. 251 s 21
- def “**registered operator**” ins 2000 SL No. 297 s 59(2)
- def “**registered owner**” om 2000 SL No. 297 s 59(1)
- def “**registration-related amount**” ins 2002 SL No. 366 s 8
- def “**repairable write-off**” ins 2002 SL No. 251 s 21
- def “**related area**” ins 2001 SL No. 248 s 15(2)
- def “**self-insurer**” ins 2002 SL No. 251 s 21
- def “**short combination truck**” sub 2000 SL No. 90 s 6(1)–(2)
- def “**special purpose vehicle**” sub 2000 SL No. 90 s 6(1)–(2)
- def “**special purpose vehicle (type 1)**” om 2000 SL No. 90 s 6(1)
- def “**special purpose vehicle (type 2)**” om 2000 SL No. 90 s 6(1)
- def “**special purpose vehicle (type o)**” ins 2000 SL No. 90 s 6(2)
- def “**special purpose vehicle (type p)**” ins 2000 SL No. 90 s 6(2)
- def “**special purpose vehicle (type t)**” ins 2000 SL No. 90 s 6(2)
- def “**statutory authority**” om 2001 SL No. 48 s 15(1)
- def “**statutory entity**” ins 2001 SL No. 248 s 15(2)
- def “**statutory write-off**” ins 2002 SL No. 251 s 21
- def “**total loss**” ins 2002 SL No. 251 s 21
- def “**vehicle law**” sub 1999 SL No. 286 s 4 sch 2
- def “**vehicle related information**” ins 2001 SL No. 248 s 15(3)
- def “**vehicle related information provider**” ins 2001 SL No. 248 s 15(3)
- def “**written-off vehicle**” ins 2002 SL No. 251 s 21
- def “**written-off vehicle inspection**” ins 2002 SL No. 251 s 21
- def “**written-off vehicle inspection report**” ins 2002 SL No. 251 s 21
- def “**written-off vehicle inspection site**” ins 2002 SL No. 251 s 21